

HIGH PRESSURE CYLINDER REGULATORS **JETCONTROL 600/S SERIES**



EDITION 1/2014

- JETCONTROL 600/S Series are single stage, two gauge cylinder regulators extensively used in oil refineries, refrigeration laboratories or industrial processes requiring precise and stable delivery of high pressure industrial gases.
- Regulators are primarily designed, tested and manufactured to operate on max. inlet pressure up to 300 Bar and providing pressure outlet up to 206 Bar. Its robust design, top grade materials and strictly controlled manufacturing and testing procedures guarantee high operational safety even if working with small molecular gases (like helium or hydrogen) at very high pressures.
- Key components are manufactured from high tensile brass, use of extra safe and accurate bulkhead gauges, double layer high grade stainless steel diaphragms and efficient metal filters help to prolong regulator service life and ensure trouble-free operation of JETCONTROL 600/S Series regulators.



PRODUCT FEATURES

- Top-safe & Accurate Bulkhead 50mm Gauges
- Transparent powder-painted surface for high corrosion resistance
- Body, bonnet and inlet stem made from high-tensile
- Technical Data permanently marked on rear side of body
- Double-layer pre-shaped stainless-steel diaphragm
- Outlet connections compatible for instant use of Parker fittings
- Bronze bush to reduce friction
- Massive T-bar for easy pressure setting

JETCONTROL 600/S SERIES

TECHNICAL DATA

Body	High tensile brass, chemically stabilized and transparent powder-painted
Bonnet	Brass, chemically stabilized and transparent powder painted
Diaphragm	Two layer, diam. 40 mm, pre-shaped stainless steel
Encapsulated valves	Brass body sealed by high-grade PA
Pressure Gauges	Safe design, bulkhead 50mm gauges, scale in Bar, accuracy class 2,5%
Inlet Stem & Nut	High-tensile brass, geometry complying with BS-341 standard
Safety Valve	Not-present, must be an independent part of downstream gas line
Pressure Setting	Stainless steel T-bar, brass pressure adjusting screw in bronze bush

DIMENSIONS SCHEME

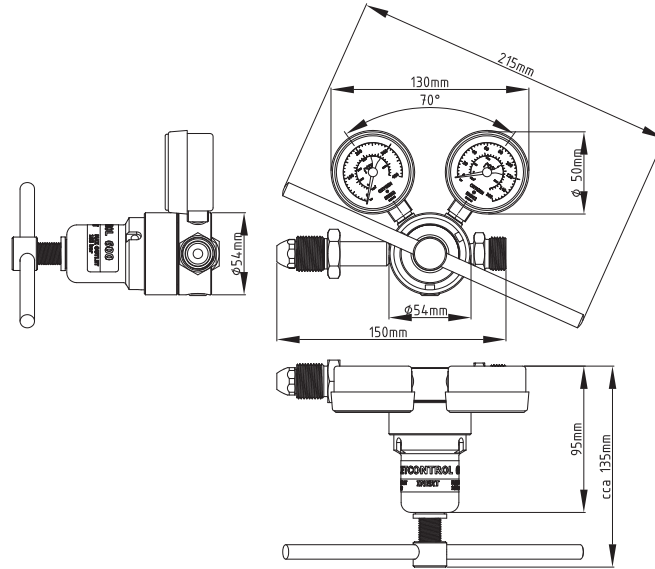

REGULATOR PARAMETERS

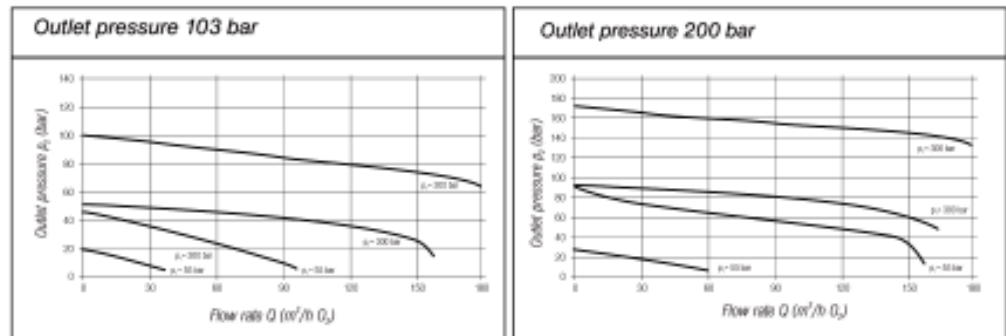

0762866



JETCONTROL 600/S SERIES RANGE

Art. Nr.	Type	Gas	Entry	Inlet (bar)	Outlet (bar)	Flow m ³ /h
0762864	S 400	Inert	bottom	300	28	36
0762865	S 1500	Inert	bottom	300	100	120
0762866	S 2500	Inert	bottom	300	170	150
0762867	S 1500	Oxygen	bottom	230	100	115
0762511	S 2500	Oxygen	bottom	230	170	140

This range of regulators is specifically designed to meet the needs of the heating, ventilation and air conditioning (HVAC) trades, for purge and leak test applications. Available in three pressure variants, the regulators are supplied with JIC fitting outlets.

Art. Nr.	Type	Inlet (bar)	Outlet (bar)	Inlet (form)	Outlet (form)
0762584	RS 400	300	28	G 5/8"	W 11x1,25
0762583	RS 600	300	41	G 5/8"	W 11x1,25
0762590	RS 750	300	52	G 5/8"	W 11x1,25

SPECIAL PURPOSE REGULATORS

"M600" SERIES

"M600" SERIES – improved delivery pressure control is achieved from two stage regulation. Typical applications are those left unattended for periods of time such as cable pressurisation, chemical and laboratory. Range up to 41 bar delivery pressure.



0762396

Art. Nr.	Type	Gas	Entry	Inlet (bar)	Outlet (bar)	Flow m ³ /h
0762398	M 600	CO ₂	side	200	41	80
0762397	M 600	Flammable	bottom	300	41	108
0762396	M 600	Inert	bottom	300	41	108
0762377	M 600	Inert	side	300	41	108
0762399	M 600	Oxygen	bottom	230	41	100

"OR14" SERIES

"OR14" SERIES – offering some of the highest flows in the GCE BUTBRO range through the use of a special monel tied valve, these are intended for cylinder and pipeline applications. The G5/8 inlet adaptor can be removed to reveal a 1" BSP flat seat female fitting. Range up to 14 bar delivery pressure.



0783594

Art. Nr.	Type	Gas	Entry	Inlet (bar)	Outlet (bar)	Flow m ³ /h
0783594	OR 14	Oxygen	rear	230	14	120

"S1510L2" SERIES

"S1510L2" SERIES – this pipeline regulator is ideal for tank systems, rear entry to suit panel or line mounting. The larger outlet configuration is necessary to give high flow from a relatively low inlet pressure source. Max inlet 24 bar and delivery up to 10 bar.



Art. Nr.	Type	Gas	Entry	Inlet (bar)	Outlet (bar)
0772037	S1510L2	Oxygen	rear	24	10

SPECIAL PURPOSE REGULATOR SUMMARY

Art. Nr.	Type	Gas	Entry	Inlet (bar)	Outlet (bar)	Flow m ³ /h
0762864	S 400	Inert	bottom	300	28	36
0762865	S 1500	Inert	bottom	300	100	120
0762866	S 2500	Inert	bottom	300	170	150
0762867	S 1500	Oxygen	bottom	230	100	115
0762511	S 2500	Oxygen	bottom	230	170	140
0762398	M 600*	CO ₂	side	200	41	80
0762397	M 600	Flammable	bottom	300	41	108
0762396	M 600	Inert	bottom	300	41	108
0762377	M 600	Inert	side	300	41	108
0762399	M 600	Oxygen	bottom	230	41	100
0783594	OR 14	Oxygen	rear	230	14	120
0772037	S 151 OL2	Oxygen	rear	24	10	

Outlet connections on "S" series regulators with delivery pressures above 28 bar are compression type, suitable for 1/4" OD tube pipework connection. S1510L2 pipeline regulator is fitted with 1" BSP RH female inlet and 3/4" BSP RH male outlet.

* for CO regulators use heaters