



BTV

Internally threaded 2-way control valve

The valves are designed for control of hot, cold or glycol-mixed water in heating and ventilation systems. They are pressure balanced (from DN20-50, not DN15) and can therefore handle high differential pressure with low force. The valves are intended to be used together with Regin's RVAN5 actuators. They should not be used in domestic water systems.

- ✓ Size DN15...50
- ✓ Kvs value 0.6...39
- ✓ Media temperature -5...+140°C
- ✓ Pressure rating PN16
- ✓ Rangeability 100:1
- ✓ No leakage
- ✓ Pressure balanced

Function

The valve is closed when the stem is in its lowest position and completely open in the highest position.

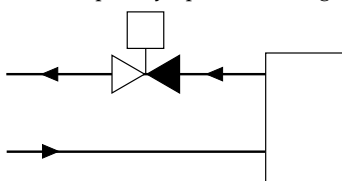

2-way valve

The valve is pressure balanced and can therefore handle high differential pressure with low actuating force. This means that an actuator with low force can be used.

Flow characteristics

The flow type is equal percentage according to the figure below.

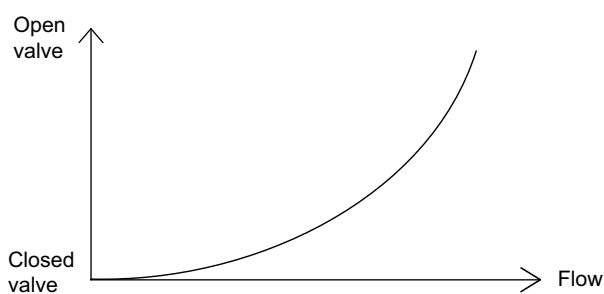

Installation

- Before installation of the control valve, ensure that the pipe is clean. Make sure that pipe scale, metal chips, welding slag and other foreign materials are removed.
- For maximum efficiency and minimum wear, install the valve in a vertical position with the stem pointing upward. If the valve is mounted with the actuator on the side, more wear is caused to the valve stuffing box. The valve should never be mounted at an angle of more than 90°.

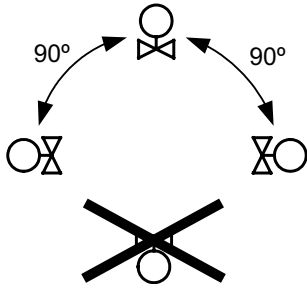

- Install the valve according to the fluid direction arrow shown on the valve.
- Make sure there is ample space above the valve to facilitate easy removal of the valve actuator.
- Fit a strainer/filter upstream of the valve to prolong the equipment's life span.
- A water quality according to VDI 2035 is recommended.

Technical data

Application	Heating systems, cooling systems, ventilation systems
Pressure rating	PN16
Connection	BSP internally threaded according to ISO 228/1
Flow characteristics	Equal percentage
Max. leakage	0.0 % of the kvs value (PTFE gasket, carbon-filled 25 %, no leakage)
Max. diff. pressure	1600 kPa
Media	Hot water, cold water, glycol-mixed water (max. 50 % glycol)
Media temperature	-5...+140 °C
Rangeability	100:1
Stroke	20 mm

Material

Body	Brass CW614N
Seat	Brass CW614N
Plug	Stainless steel 1.4301
Stem	Stainless steel 1.4305
Seat packing	PTFE with 25 % carbon
O-rings	EPDM

Models

Article	Nominal diameter	Connection	Kvs	Actuator
BTV15-0,6	DN15	G½"	0.6	RVAN5
BTV15-1,0	DN15	G½"	1.0	RVAN5
BTV15-1,6	DN15	G½"	1.6	RVAN5
BTV15-2,5	DN15	G½"	2.5	RVAN5
BTV20-1,6	DN20	G¾"	1.6	RVAN5
BTV20-2,7	DN20	G¾"	2.7	RVAN5
BTV20-3,9	DN20	G¾"	3.9	RVAN5
BTV25-6,3	DN25	G1"	6.3	RVAN5
BTV25-10	DN25	G1"	10	RVAN5
BTV32-10	DN32	G1¼"	10	RVAN5
BTV32-16	DN32	G1¼"	16	RVAN5
BTV40-16	DN40	G1½"	16	RVAN5
BTV40-27	DN40	G1½"	27	RVAN5
BTV50-27	DN50	G2"	27	RVAN5
BTV50-39	DN50	G2"	39	RVAN5

Accessories

Article	Description
S02420001	Spare parts kit, O-ring kit for BTV valves from DN15 to DN25
S6321457301	Spare parts kit, packing box

Dimensions

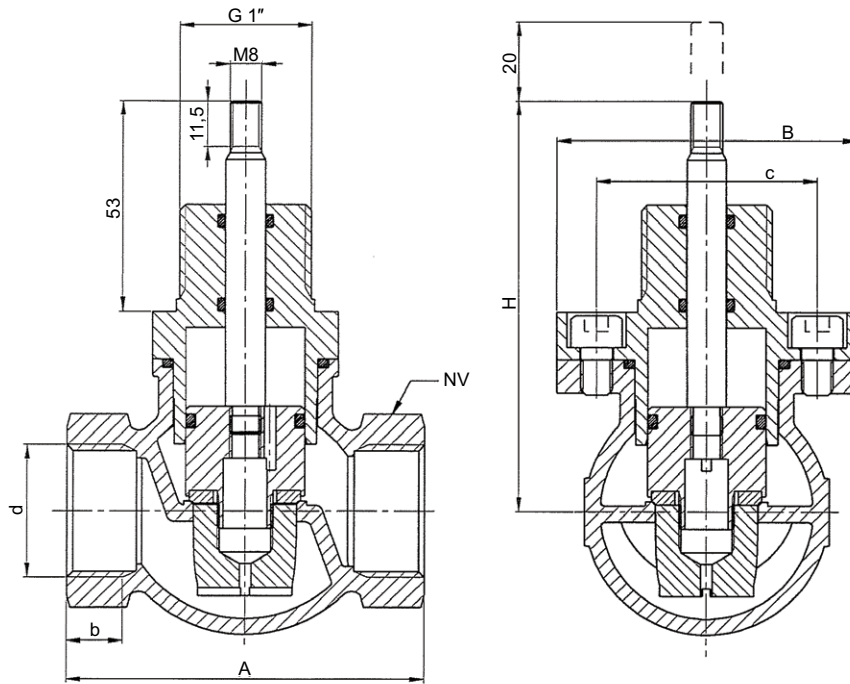

DN	d	A	b	H	B	c	NV
15	G1/2"	70	11	90	62	47	30
20	G3/4"	75	13	90	62	47	36
25	G1"	90	14	104	76	56	42
32	G1 1/4"	105	17	104	64	44	52
40	G1 1/2"	120	18	120	67	50	58
50	G2"	145	20	124	77	60	70

Measurements in mm unless otherwise specified.

Pressure drop diagram

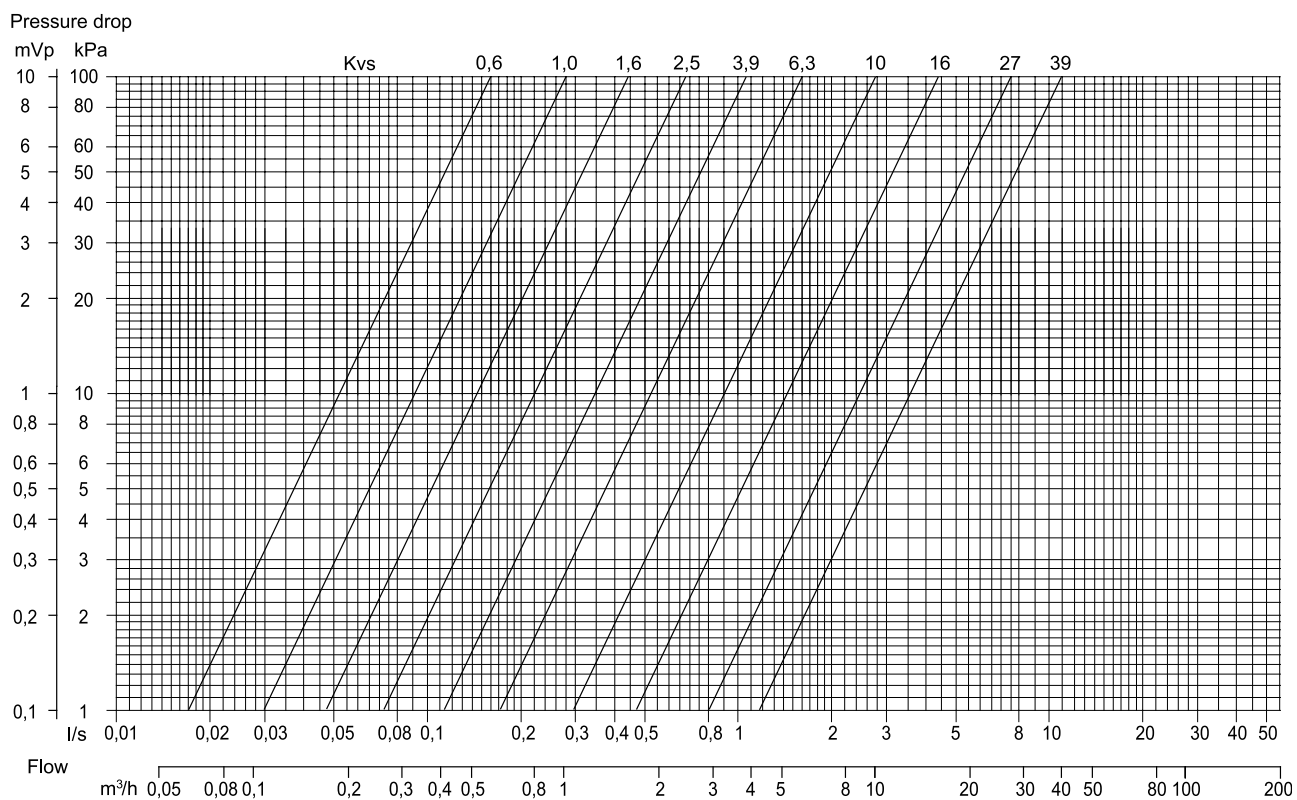

Example: calculation of kv value

If the pressure drop is 10 kPa (A) and the flow is 0.8 m³/h (B), the kv value is 2.5 (C). See the markings in the picture to the right.

