

Alarm Siren and Strobe



S-350

Features

- Operation current : Fire Bell with strobe LED, 50mA, 65mA max. at 24VDC.
- Continue operation test at 24VDC : over 72 hours.
- Life test : on : 1 minute, off : 30 seconds.
- Duty cycle at 24VDC : continuously over 500 hours period.

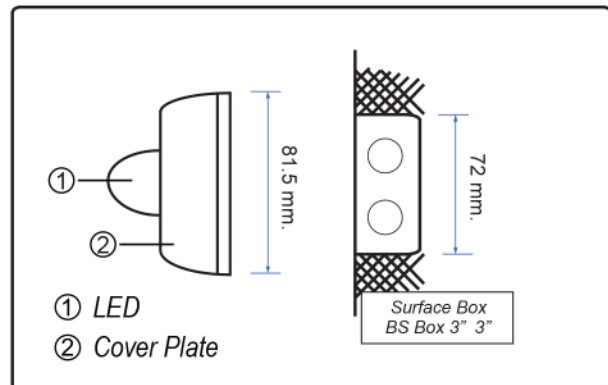

Specification

Model	S-350
Input Voltage	DC 24V (12 - 24V)
Alarm Current	50mA @ 24V
Strobe	over 8,000 mcd. (6pcs super bright LED)
Sound Output	100 dB +/- 5 dB @ 24V
Tone Type	Alarm Siren
Operation Trmp	-10 °C - + 60 °C
Dimension (W x H x D)	81.5 x 81.5 x 52 mm