

**Communication-capable globe valve actuator
for 2-way and 3-way globe valves**

- Actuating force 2500N
- Nominal voltage AC/DC 24V
- Control modulating DC (0)0.5V...10V, variable
- Nominal stroke 40mm



Technical data

Electrical data	Nominal voltage	AC/DC 24V
	Nominal voltage frequency	50/60Hz
	Nominal voltage range	AC 19.2...28.8V / DC 21.6...28.8V
	Power consumption in operation	4W
	Power consumption in rest position	1.5W
	Power consumption for wire sizing	6VA
	Connection supply / control	Terminals 4mm ² and cable 1m, 4 x 0.75mm ²
	Parallel operation	Yes
Functional data	Actuating force	2500N
	Positioning signal Y	DC 0...10V
	Positioning signal Y note	Input impedance 100kΩ
	Operating range Y	DC 0.5...10V
	Operating range Y variable	Start point DC 0.5...30V End point DC 2.5...32V
	Position feedback U	DC 0.5...10V
	Position feedback U note	max. 0.5mA
	Position feedback U variable	Start point DC 0.5...8V End point DC 2.5...10V
	Position accuracy	5% absolute
	Manual override	Gear disengagement with push-button, can be locked
	Nominal stroke	40mm
	Actuating time	150s/40mm
	Override control MAX (maximum position)	100%
	Override control MIN (minimum position)	0%
	Override control ZS (intermediate position, only AC)	50%
	Override control ZS variable	ZS = MIN...MAX
	Sound power level motor max.	55dB(A)
Sound power level motor note	55dB(A) @ 90s running time	
Position indication	Mechanical 5...40mm stroke	
Safety	Protection class IEC/EN	III Safety extra-low voltage
	Degree of protection IEC/EN	IP54
	EMC	CE in accordance with 2004/108/EC
	Certification IEC/EN	Certified to: IEC/EN 60730-1 and IEC/EN 60730-2-14
	Mode of operation	Type 1
	Rated impulse voltage supply / control	0.8kV
	Control pollution degree	3
	Ambient temperature	0°C...50°C
	Non-operating temperature	-40°C...80°C
	Ambient humidity	95% r.h., non-condensing
Weight	Maintenance	Maintenance-free
	Weight approx.	4.32kg

Safety notes



- This actuator has been designed for application in stationary heating, ventilation and air-conditioning systems and is not allowed to be used outside the specified field of application, especially in aircraft or in any other airborne means of transport.
- Only authorised specialists may carry out installation. All applicable legal or institutional installation regulations must be complied with during installation.
- The switch for changing the direction of motion/the closing point may be adjusted only by authorised personnel. The direction of stroke is critical, particularly in connection with frost protection circuits.
- The device may only be opened at the manufacturer's site. It does not contain any parts that can be replaced or repaired by the user.
- The device contains electrical and electronic components and is not allowed to be disposed of as household refuse. All locally valid regulations and requirements must be observed.

Product features

Principle of operation	The actuator is connected with a standard modulating signal of DC 0...10V and travels to the position defined by the positioning signal. The measuring voltage U serves for the electrical display of the actuator position 0...100% and as slave control signal for other actuators.
Adjustable-parameter actuators	The factory settings cover the most common applications. Input and output signals and other parameters can be altered with the PC-Tool MFT-P or with the service tool ZTH-GEN.
Direct mounting	Simple direct mounting on the globe valve by means of form-fit hollow clamping jaws. The actuator can be rotated through 360° on the valve neck.
Manual override	Manual override with push-button possible - temporary, permanently. The gear is disengaged and the actuator decoupled for as long as the button is pressed / latched. The stroke can be adjusted by using a hexagon socket screw key (5mm), which is inserted into the top of the actuator. The stroke spindle extends when the key is rotated clockwise.
High functional reliability	The actuator is overload protected, requires no limit switches and automatically stops when the end stop is reached.
Combination valve/actuator	Refer to the valve documentation for suitable valves, their permitted medium temperatures and closing pressures.
Position indication	The stroke is indicated mechanically on the bracket with tabs. The stroke range adjusts itself automatically during operation.
Home position	Setting ex-works: Actuator spindle is retracted. When valve-actuator combinations are shipped, the direction of motion is set in accordance with the closing point of the valve.
Direction of stroke switch	When actuated, the direction of stroke switch changes the running direction in normal operation.
Adaption of stroke range	The first time the supply voltage is switched on, i.e. at the time of commissioning, the actuator carries out a stroke adaption, which is when the operating range and position feedback adjust themselves to the mechanical stroke. Manual triggering of the adaption can be carried out by pressing the "Adaption" button or with the PC-Tool. The actuator then moves into the position defined by the positioning signal.

Accessories

	Description	Type
Electrical accessories	Auxiliary switch add-on, 2 x SPDT	S2A-H
Service tools	Manual parameterising device, for MF/MP/Modbus/LonWorks actuators and VAV-Control	ZTH-GEN
	Belimo PC-Tool, software for adjustments and diagnostics	MFT-P

Electrical installation



Notes • Connection via safety isolating transformer.
 • Parallel connection of other actuators possible.
 • Direction of stroke switch factory setting: Actuator spindle retracted.

Wiring diagrams

AC/DC 24V, modulating

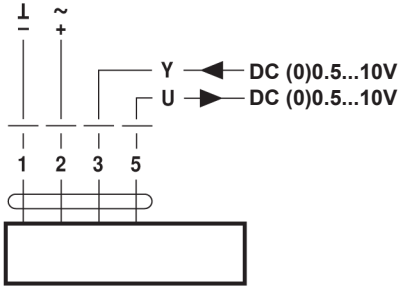

Cable colours:
 1 = black
 2 = red
 3 = white
 5 = orange

Operation on the MP-Bus

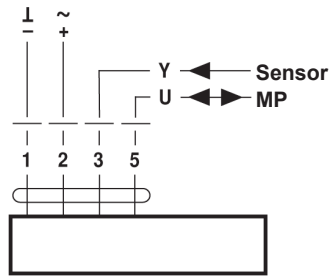

Cable colours:
 1 = black
 2 = red
 3 = white
 5 = orange

Functions

Functions with basic values

Override control with AC 24V with relay contacts

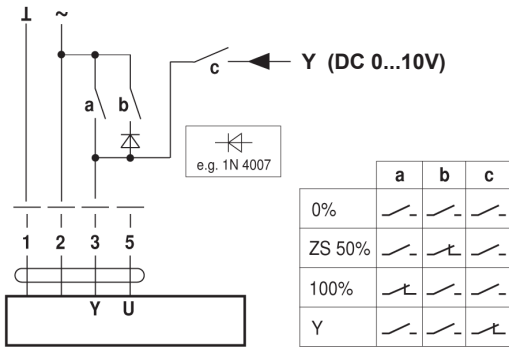

Override control with AC 24V with rotary switch

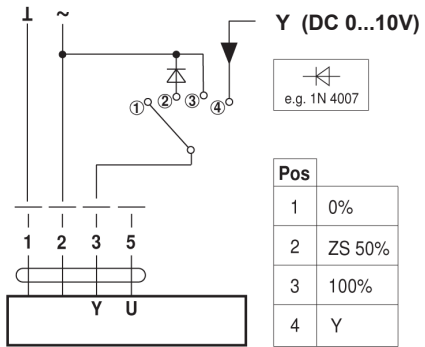

Remote control 0...100%

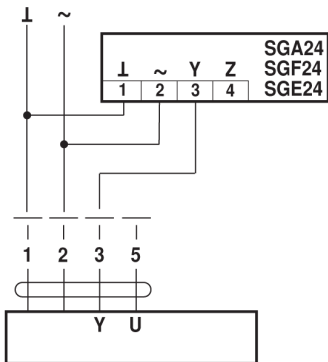

Follow-up control (position-dependent)

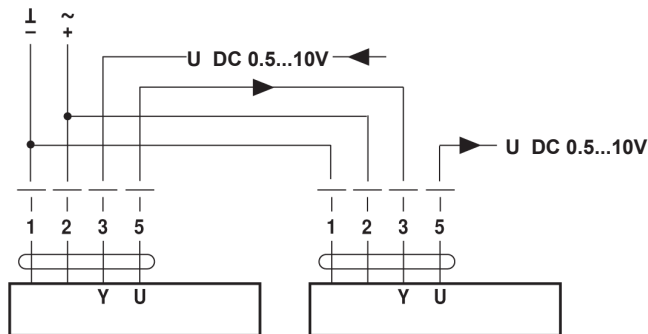

Functions

Control with 4...20mA via external resistor

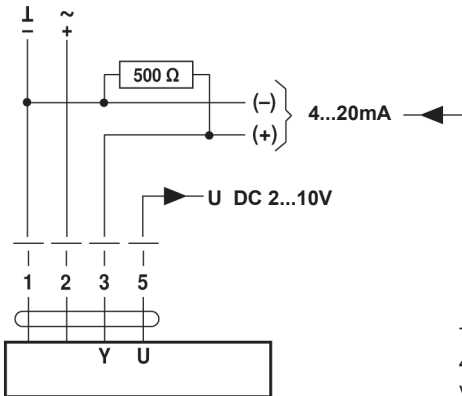

The 500Ω resistor converts the 4...20mA current signal to a voltage signal DC 2...10V

Functions for actuators with specific parameters

Override control and limiting with AC 24V with relay contacts

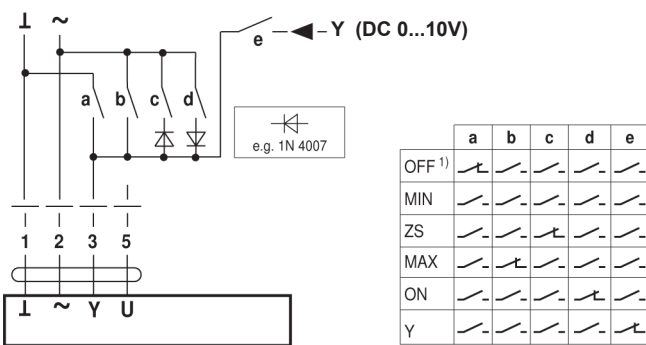

Override control and limiting with AC 24V with rotary switch

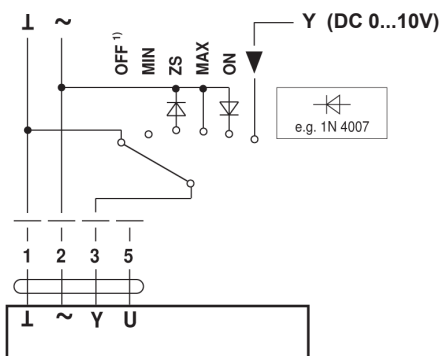

1) Caution: This function is guaranteed only if the start point of the operating range is defined as min. 0.6V.

Functions

AC 24V, 3-point

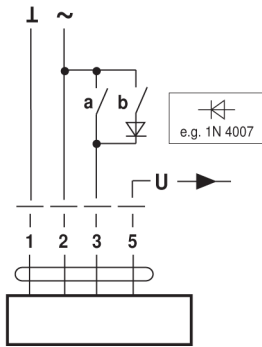

a	b		

Functions when operated on MP-Bus

Connection on the MP-Bus

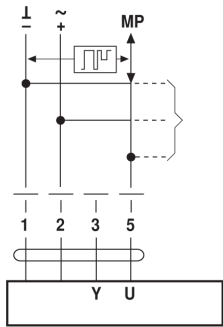

- Supply and communication in one and the same 3-wire cable
- no shielding or twisting required
 - no terminating resistor required

Power topology

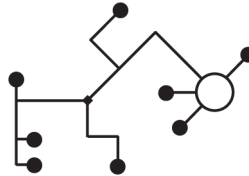

There are no restrictions for the network topology (star, ring, tree or mixed forms are permitted).

Connection of active sensors

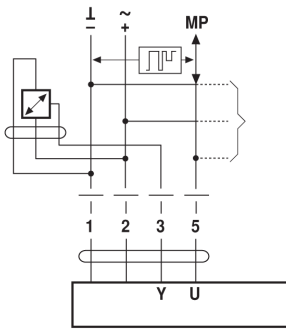

- Supply AC/DC 24A
- Output signal DC 0...10V (max. DC 0...32V)
- Resolution 30mV

Connection of external switching contact

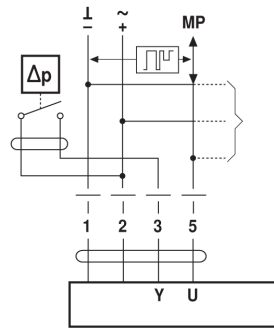

- Switching current 16mA @ 24V
- Start point of the operating range must be parameterised on the MP actuator as $\geq 0.6V$

Connection of passive sensors

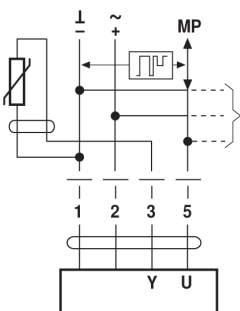

Ni1000	-28 ... +98 °C	850 ... 1600 Ω ²⁾
PT1000	-35 ... +155 °C	850 ... 1600 Ω ²⁾
NTC	-10 ... +160 °C ¹⁾	200 Ω ... 50 k Ω ²⁾

1) Depending on the type
2) Resolution 1 Ohm

Indicators and operating controls

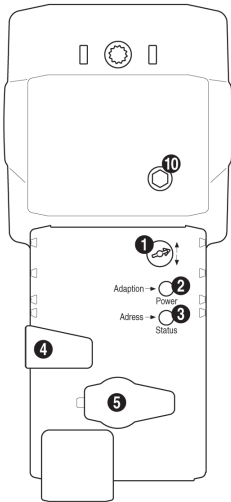

(1) Direction of stroke switch

Switching: Direction of stroke changes

(2) Push-button and LED display green

Off: No power supply or malfunction

Illuminated in green: In operation

Press button: Triggers stroke adaption, followed by standard mode

(3) Push-button and LED display yellow

Off: Standard mode

Flickering: MP communication active

Illuminated: Adaption procedure active

Blinking: Request for addressing from MP master

Press button: Confirmation of addressing

(4) Gear disengagement button

Press button: Gear disengages, motor stops, manual override possible

Release button: Gear engages, standard mode

(5) Service plug

For connecting the parameterisation and service tools

(10) Manual override

Clockwise: Actuator spindle extends

Counterclockwise: Actuator spindle retracts

LED displays (2, green) and (3, yellow)

green: Off; yellow: Illuminated;

Check the supply connections. The phases may have been switched.

Dimensions [mm]

Dimensional drawings

