

MDV

Double Power Vise

- Consists of Two movable Jaws and One fixed Center Jaw for Double clamping
- Equipped with step Jaw & Middle Jaw suitable for various workpieces
- Seal structure makes preventing the inner body from inflowing dust
- Realize High Clamping Force by Mechanical gravity Device



POWER VISE

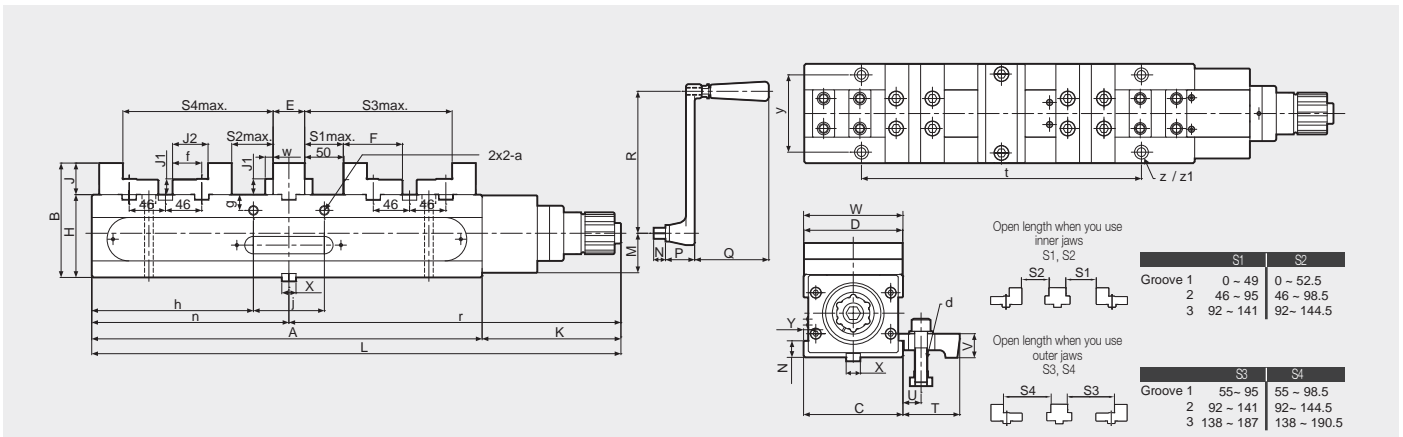

Dimensions

	A	B	C	D	E	F	H	J	J1	J2	K	L	M	N	P	Q	R
MDV-125	495	145	126	125	40	75	105	40	20	45	176	671	50	15	37	94	180

	T	U	V	W	X	Y	a	d	e	f	g	h	j	n	r	t	y	z	z1	w
MDV-125	72	15-31	30.5	126	18	6	M10	M16x65L	42	37	20	205	90	250	421	355	98	11	17.5	10

Specifications

Type	Jaw Width	Jaw Height	Max. Opening				Total Height	Slider Height	Total Width	Total Length	Max. Gripping Force	Weight
	[mm]	[mm]	S1	S2	S3	S4	[mm]	[mm]	[mm]	[mm]	[kN(kgf)]	[kgf]
MDV-125	125	40	141	144.5	187	190.5	145	105	126	671	40(4355)	52

