

# PCV

## Standard Power Vise

- Precision power vise with adjustable torque



**POWER VISE**

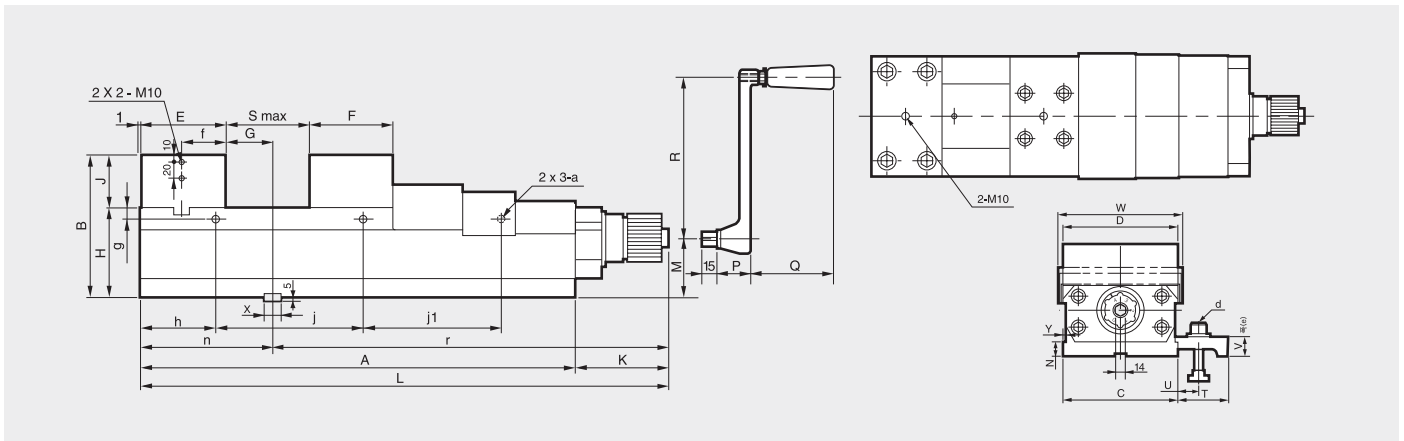

### Dimensions

|              | A   | B   | C   | D   | E   | F   | G    | H   | J  | K     | L     | M  | N  | P  | Q  | R   | S   |
|--------------|-----|-----|-----|-----|-----|-----|------|-----|----|-------|-------|----|----|----|----|-----|-----|
| PCV-100(4")  | 295 | 115 | 101 | 100 | 73  | 64  | 38.5 | 75  | 40 | 105.5 | 400.5 | 43 | 15 | 37 | 95 | 180 | 150 |
| PCV-125(5")  | 400 | 135 | 126 | 125 | 84  | 76  | 60   | 85  | 50 | 105.5 | 505.5 | 50 | 21 | 37 | 95 | 180 | 230 |
| PCV-160(6")  | 490 | 160 | 161 | 160 | 94  | 86  | 50   | 100 | 60 | 105.5 | 595.5 | 65 | 21 | 37 | 95 | 180 | 300 |
| PCV-200(8")  | 533 | 180 | 202 | 200 | 102 | 98  | 74   | 110 | 70 | 105.5 | 638.5 | 75 | 21 | 37 | 95 | 180 | 320 |
| PCV-250(10") | 705 | 195 | 252 | 250 | 120 | 120 | 100  | 115 | 80 | 105.5 | 810.5 | 75 | 21 | 37 | 95 | 180 | 450 |

|              | T  | U     | V    | W   | X  | Y | a   | b      | e  | f    | g  | h   | j   | j1  | j2  | n     | r     |
|--------------|----|-------|------|-----|----|---|-----|--------|----|------|----|-----|-----|-----|-----|-------|-------|
| PCV-100(4")  | 60 | 14-26 | 22.5 | 107 | 14 | 6 | M10 | M12x45 | 35 | 36.5 | 12 | 95  | 105 | -   | -   | 112.5 | 288.0 |
| PCV-125(5")  | 72 | 15-31 | 30   | 135 | 18 | 6 | M10 | M16x65 | 45 | 42   | 12 | 95  | 105 | 105 | -   | 145   | 360.5 |
| PCV-160(6")  | 72 | 15-31 | 30   | 170 | 18 | 7 | M10 | M16x65 | 45 | 47   | 12 | 105 | 140 | 140 | -   | 145   | 450.5 |
| PCV-200(8")  | 72 | 15-31 | 30   | 214 | 18 | 7 | M10 | M16x65 | 45 | 51   | 12 | 126 | 141 | 141 | -   | 177   | 461.5 |
| PCV-250(10") | 72 | 15-31 | 30   | 267 | 22 | 7 | M10 | M20x65 | 45 | 60   | 12 | 140 | 140 | 140 | 140 | 221   | 589.5 |

### Specifications

| Type          | Jaw Width | Jaw Height | Max. Opening | Total Height | Slider Height | Total Width | Total Length | Max.Gripping Force | Weight |
|---------------|-----------|------------|--------------|--------------|---------------|-------------|--------------|--------------------|--------|
|               | [mm]      | [mm]       | [mm]         | [mm]         | [mm]          | [mm]        | [mm]         | [kN(kgf)]          | [kgf]  |
| PCV-100 (4")  | 100       | 40         | 150          | 115          | 75            | 107         | 400          | 25(2551)           | 25     |
| PCV-125 (5")  | 125       | 50         | 230          | 135          | 85            | 135         | 505          | 35(3571)           | 43     |
| PCV-160 (6")  | 160       | 60         | 300          | 160          | 100           | 170         | 595          | 60(6122)           | 65     |
| PCV-200 (8")  | 200       | 70         | 320          | 180          | 110           | 214         | 638          | 60(6122)           | 100    |
| PCV-250 (10") | 250       | 80         | 450          | 195          | 115           | 264         | 810          | 80(8163)           | 150    |

※ Specifications are subject to change without notice.

