

S-120,120L

Controller type for NC Rotary Table



S-SERIES

- High Precision, High Speed Systems
- Vertical & Horizontal available
- Compact Design
- Extremely Solid Body
- High Clamping power

Model No.

S-120L

Motor Side

Table Diameter

TYPE : Single Spindle NC Rotary Table(Standard)

S-120

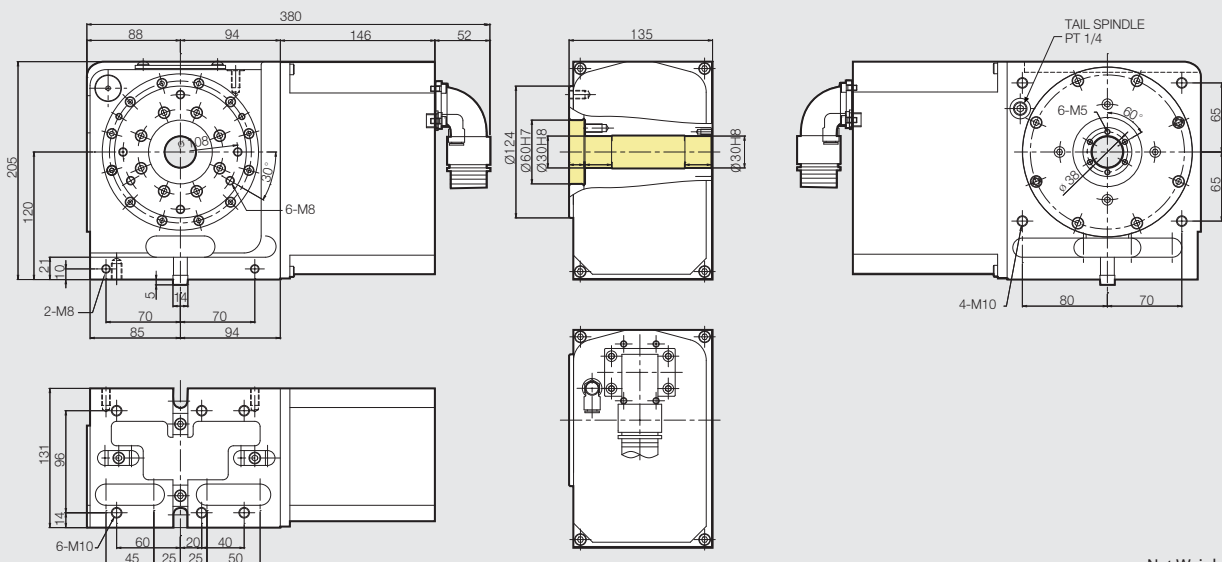

Net Weight(kg) : 33

S-120L

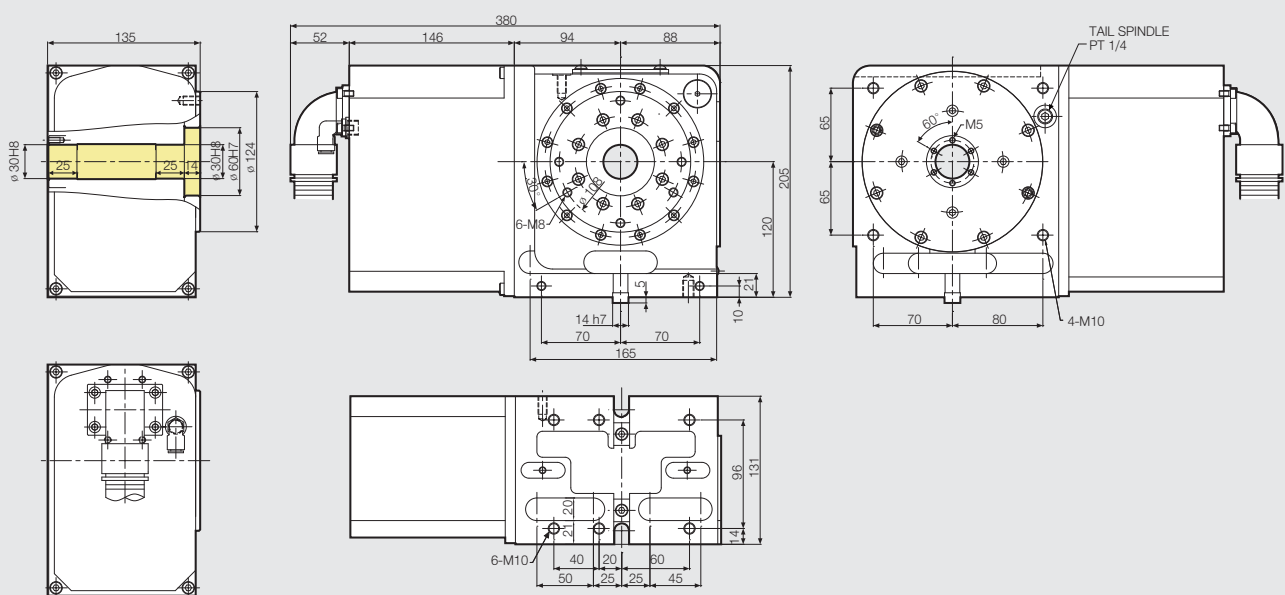

Net Weight(kg) : 33

S-170, 170L

Controller type for NC Rotary Table



- High Precision, High Speed Systems
- Vertical & Horizontal available
- Compact Design
- Extremely Rigid Body
- Realize High Clamping Force by applying Double Piston

S-SERIES

Model No. **S-170L**

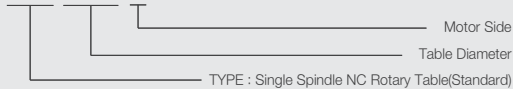

S-170

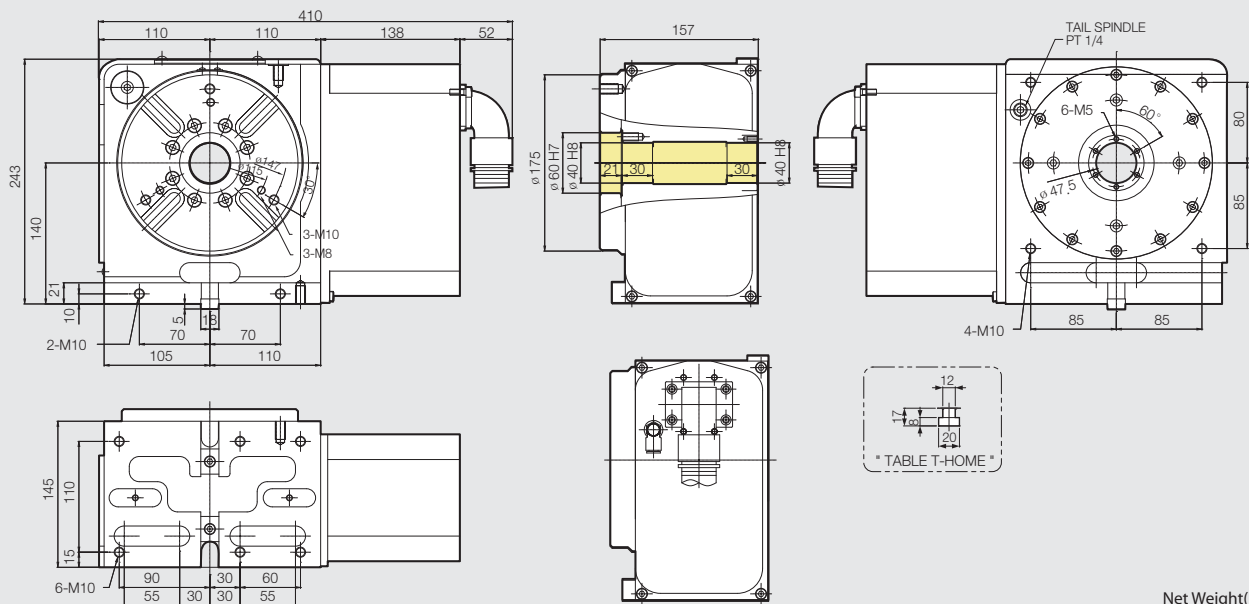

Net Weight(kg) : 50

S-170L

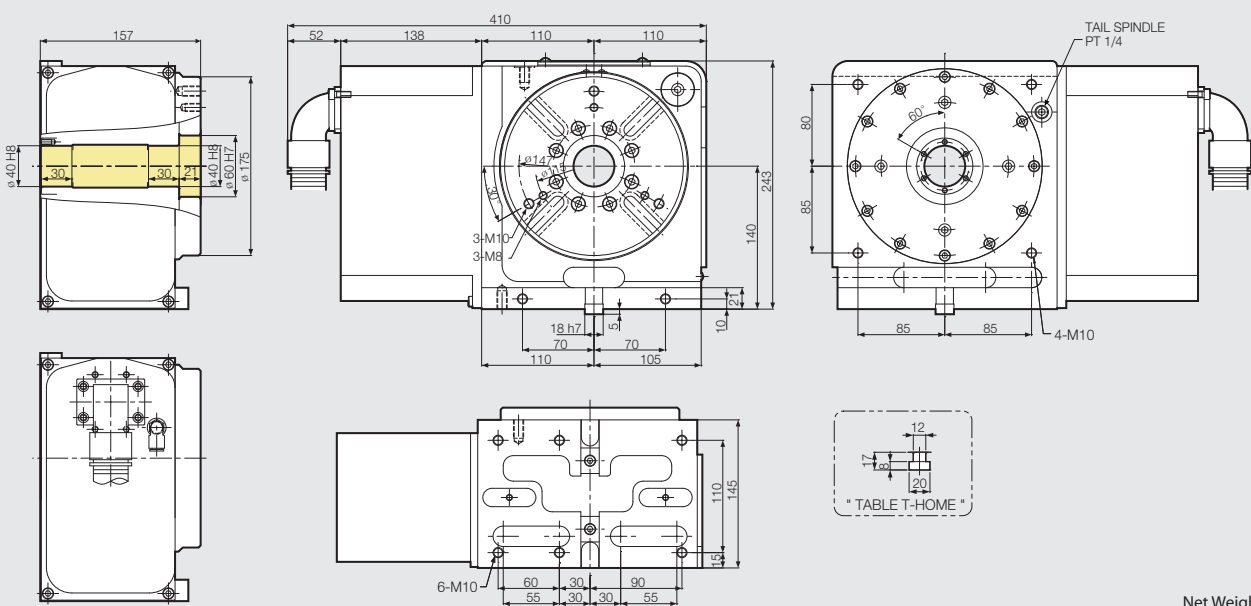

Net Weight(kg) : 50

S-200, 200L

Controller type for NC Rotary Table

- High Precision, High Speed Systems
- Vertical & Horizontal available
- Compact Design
- Extremely Rigid Body
- Realize High Clamping Force by applying Double Piston

S-SERIES



Model No. **S-200L**



S-200

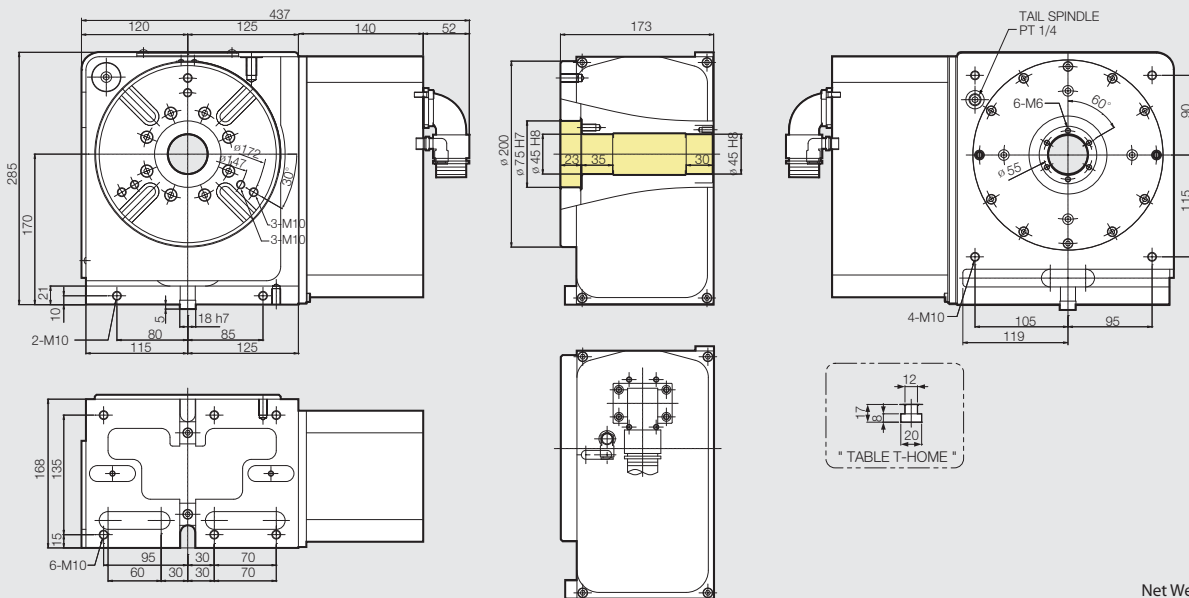

Net Weight(kg) : 71

S-200L

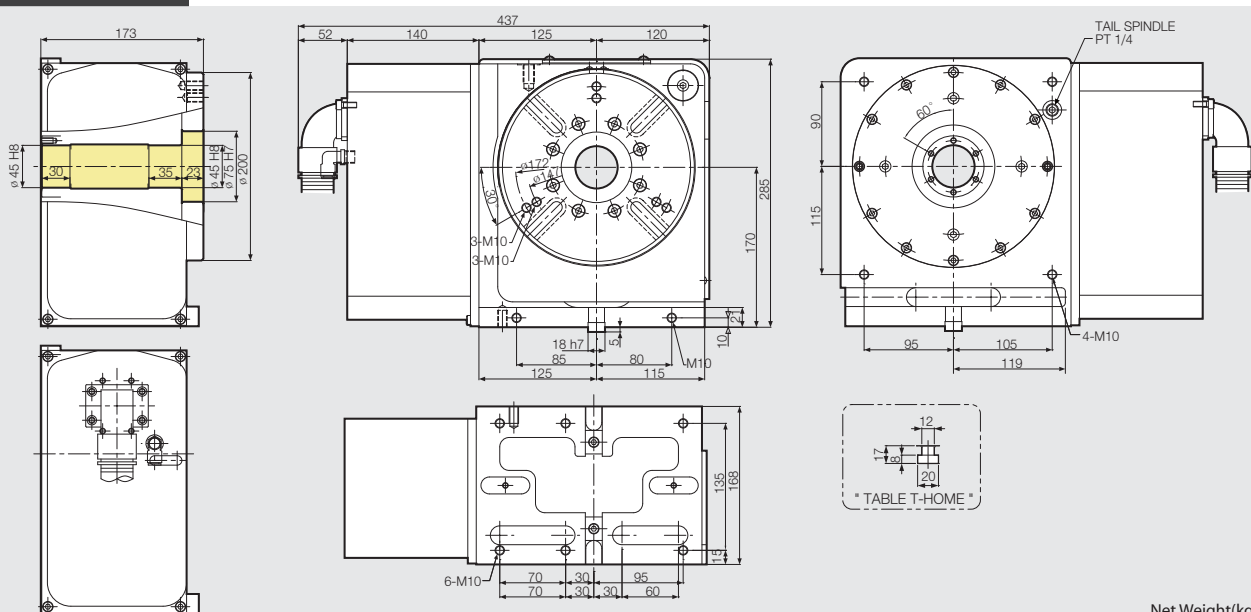

Net Weight(kg) : 71



S-250i, 250Li

Controller type for NC Rotary Table

- High Precision, High Speed Systems
- Vertical & Horizontal available
- Compact Design
- Extremely Rigid Body
- Realize High Clamping Force by applying Double Piston

S-SERIES



Model No.

S-250Li

Motor Spec (None : 1HP, i : 2HP)
 Motor Side (None : Right, L : Left)
 Table Diameter

TYPE : Single Spindle NC Rotary Table(Standard)

S-250i

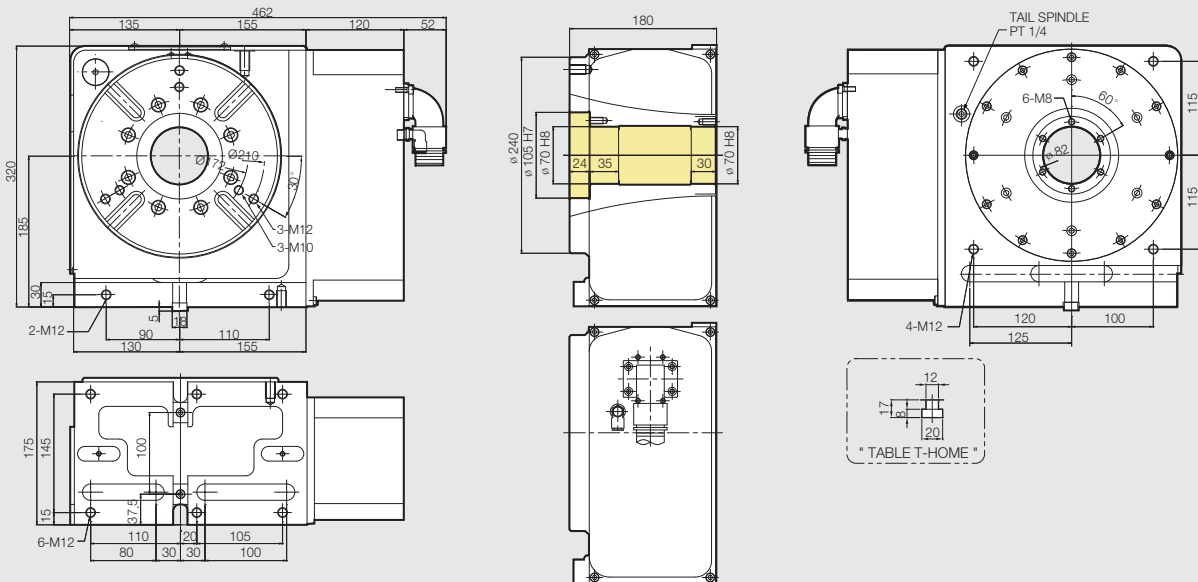

Net Weight(kg) : 91

S-250Li

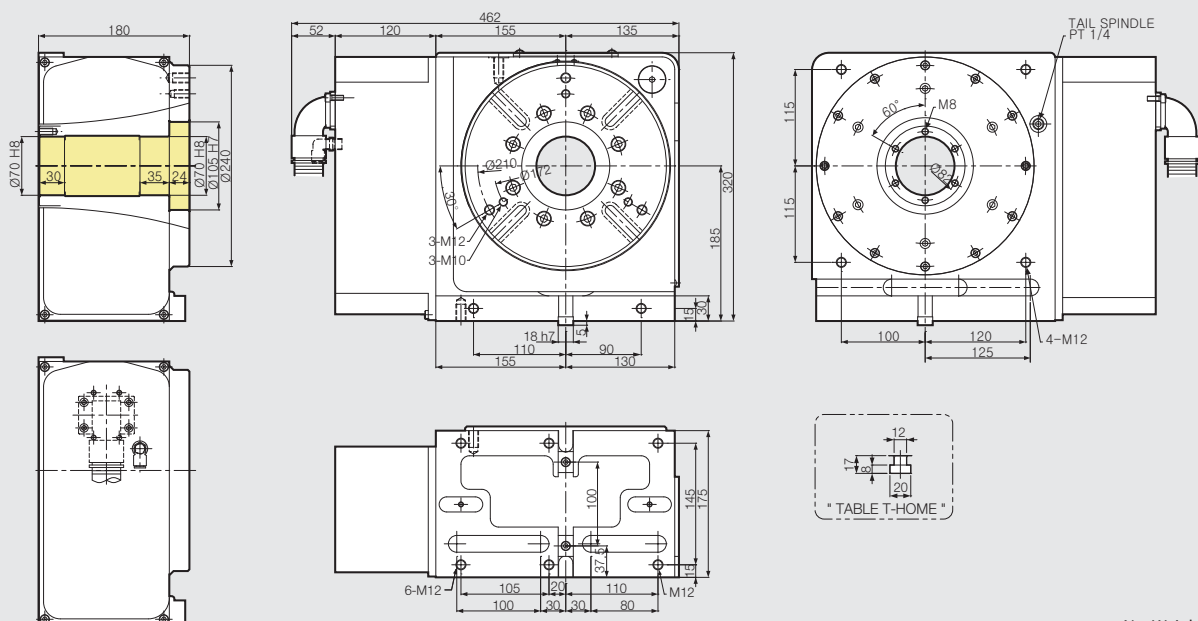

Net Weight(kg) : 91

S-320i, 320Li

Controller type for NC Rotary Table



- High Precision, High Speed Systems
- Vertical & Horizontal available
- Compact Design
- Extremely Rigid Body
- Realize High Clamping Force by applying Double Piston

S-SERIES

Model No.

S-320Li

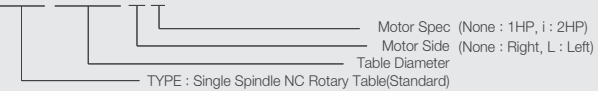

S-320i

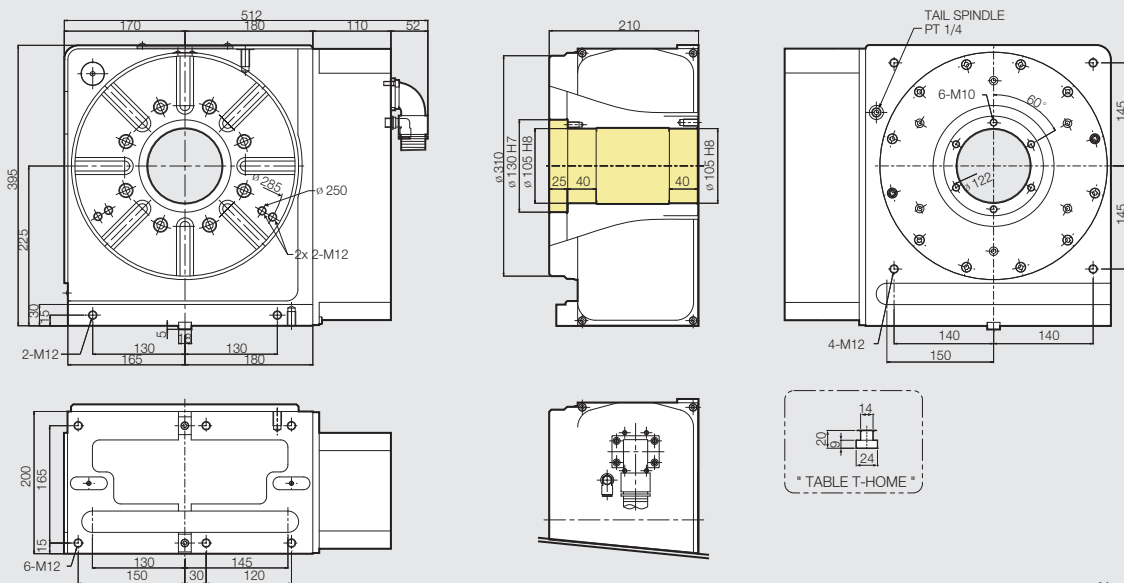

Net Weight(kg) : 154

S-320Li

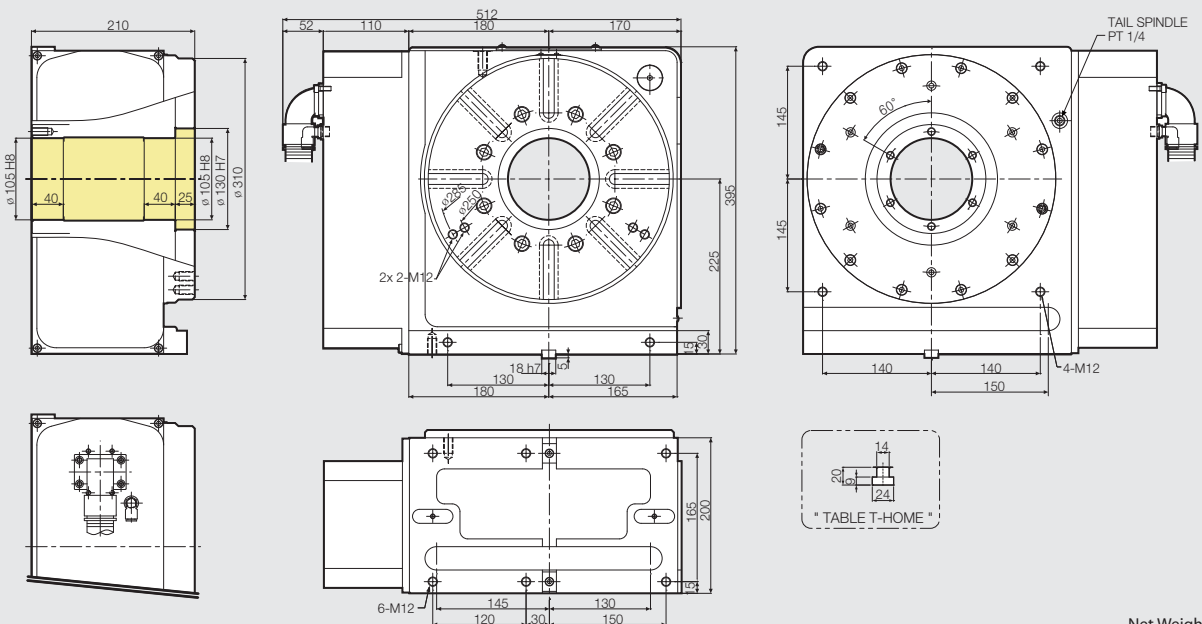

Net Weight(kg) : 154