

MCH

Stationary Hydraulic Chuck

- Compact design with built-in cylinder enables wider workspace
- Compatible with hydraulic chucks



HYDRAULIC CHUCK

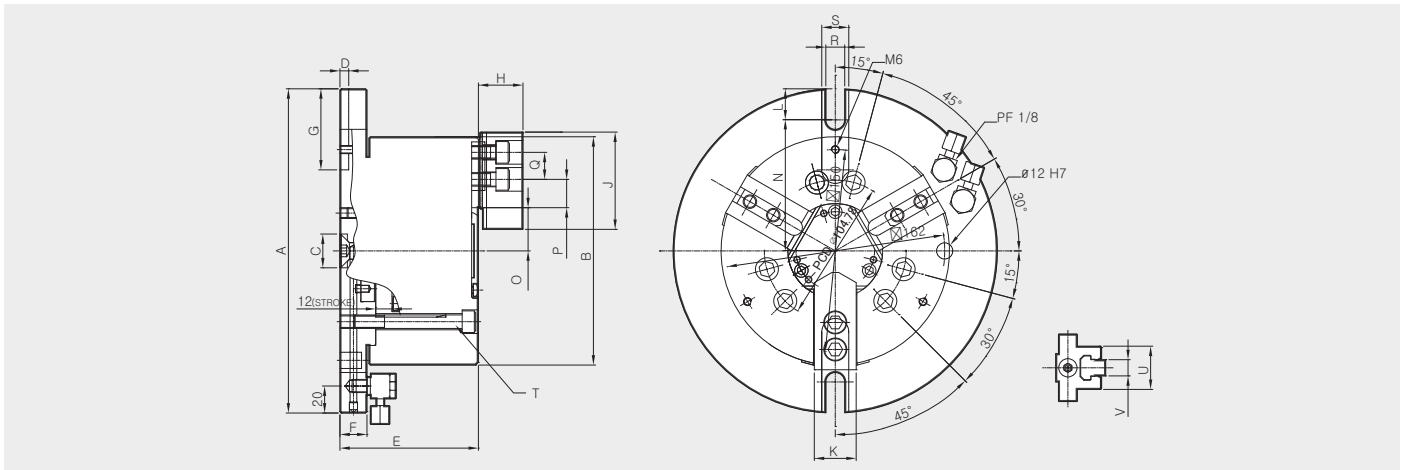

Dimensions

	ΦA	ΦB	ΦC	D	E	F	G	H	J	K	L	N	Omax.	Omin.	Pmax.	Pmin.	Q	R	S	T	U	V
MCH-06	240	169	25	6.5	102.5	20	60	33	72	31	23	97	32	29.25	22.75	9.25	20	14	20	M10	32	12

Specifications

Type	Clamping Force (Hydraulic 6bar)	Jaw Stroke Dia.	Chucking Dia.		Max. Hydraulic Pressure	Weight
	[kgf]	[mm]	Max. [mm]	Min. [mm]	[bar]	[kg]
MCH-06	57kN (5812)	5.5	169	15	19.5(198.8)	18