

IAN

Auto-Indexing Chuck

- Machine multiple surfaces in a single clamping
- On-the-fly indexing
- Accurate, durable indexing system
- Index positions 3 x 120° / 4 x 90°

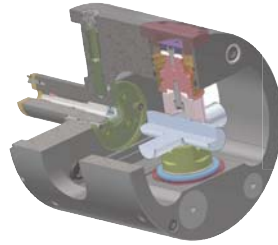

SPECIAL CHUCK

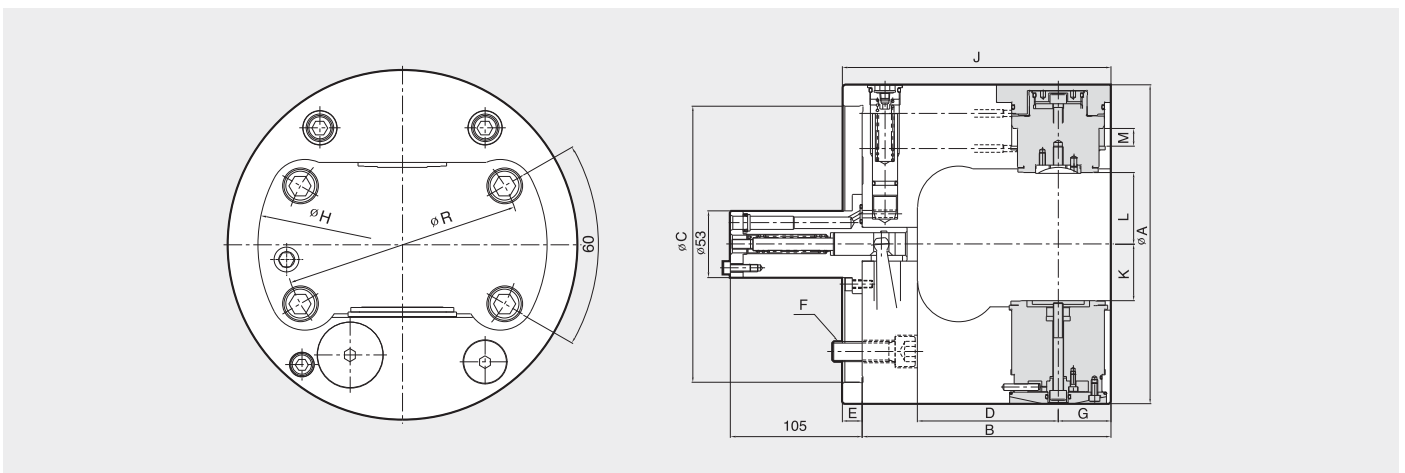

Dimensions

	ΦA	B	ΦC(h7)	D	E	F	G	ΦH	J	K	L	M	R
IAN-235	235	172	170	102	16	M12	30	206	188	42.5	54.5	15	133.4
IAN-254	254	198	220	112	16	M16	42	228	214	45	57	17	171.4
IAN-280	280	211	220	125	16	M16	42	250	227	58	70	17	171.4

Specifications

Type	Clamp Piston Area	Max. Pressure	Max. Speed	Weight	GD ²
	[cm ²]	[kgf·m ²]	[r.p.m.]	[kg]	[kgf·m ²]
IAN-230	30	45	3000	32	0.27
IAN-254	43	45	2500	45	0.47
IAN-280	43	45	2300	55	0.88

Indexing Position

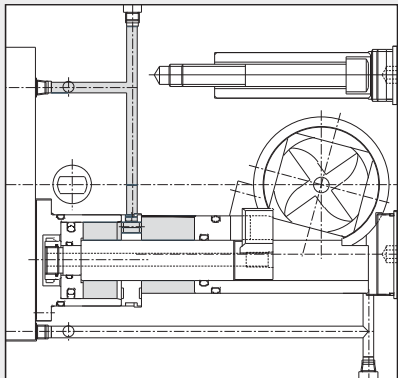

0°

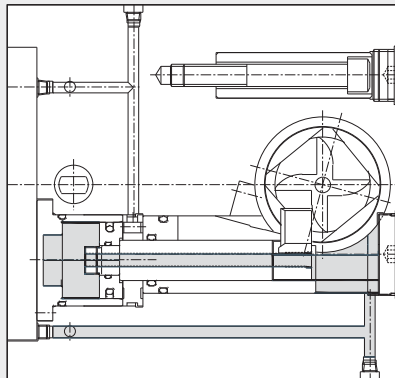

45° INDEX

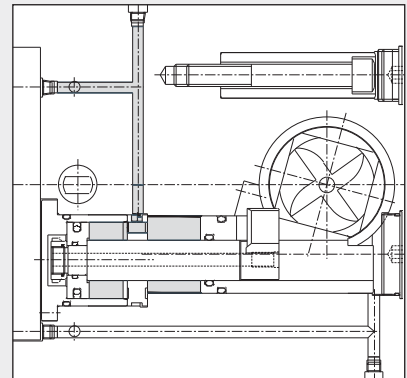

90° INDEX

Work Pieces

