

GDP

Gear Chuck

- Diaphragm chuck for hard turning/ grinding gears
- Jaws can be easily changed



SPECIAL CHUCK

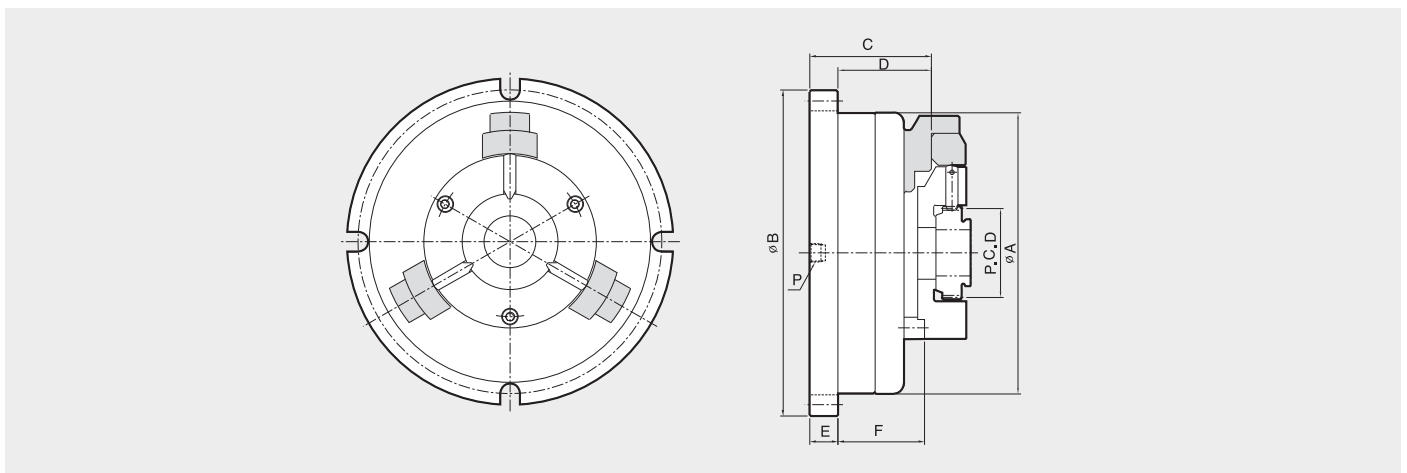

Dimensions

	ΦA	ΦB	C	D	E	F	P	H	Lmax.	Lmin.	M	ΦN	O	Pmax.	Pmin.
GDP-08	212.9	246	96.8	77.7	19.1	70	1/4	55	54	30	36	40	M16	44	30
GDP-10	251	284	96.8	77.7	19.7	85	1/4	75	59	35	36	45	M20	50	35
GDP-13	327.2	360	108	88.9	19.1	85	1/4	95	72	40	46	55	M24	60	40
GDP-17	428.9	476	109.5	90.4	19.1	85	1/4	120	72	45	46	55	M24	60	40

Specifications

Type	Max. Clamping Force	No. of Jaw	Jaw Stroke	Grip Dia.	Max. Speed	Pressure	Weight
	[kgf]		[mm]	[mm]	[r.p.m.]	[kgf/cm ²]	[kg]
GDP-08	720	3	0.25	40-70	4000	4.5	20
GDP-10	1150	3	0.25	70-100	3500	4.5	26.5
GDP-13	2000	3	0.35	100-160	3000	4.5	43
GDP-17	3600	3	0.40	160-250	2000	4.5	89