

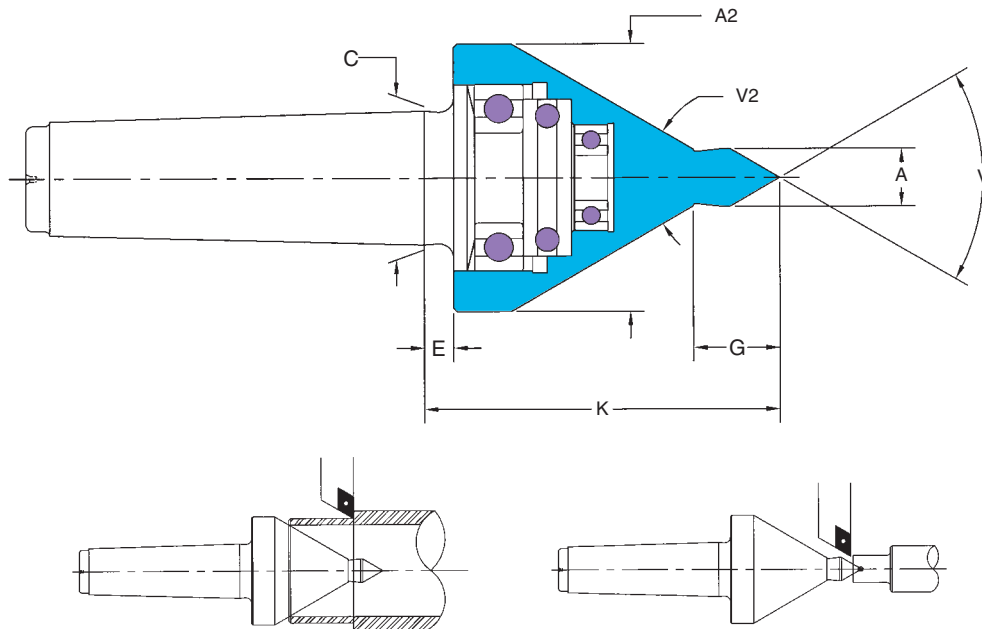

## Multi-Use Live Center

- Accurate to  $\pm .0001$ .
- Great for manual lathe applications.
- Riten full service and repair.

The Multi-Use live center is ideal for general machine shop use. It can be used when machining thin-walled workpieces or general shaft work applications. The versatility of this center makes it a "must have" tool when your center needs change frequently.



MULTI-USE LIVE CENTER - MORSE TAPER

Model	MT	A	A2	C	E	G	K	V	V2	Max RPM	W. P. Weight
60222	2	1/2	21/4	.700	1/4	3/4	33/16	60°	60°	5000	330
60223	3	1/2	21/4	.938	1/4	3/4	33/16	60°	60°	5000	330
60263	3	5/8	25/8	.938	1/4	15/16	33/16	60°	60°	4000	685
60264	4	5/8	25/8	1.231	3/8	15/16	37/8	60°	60°	4000	685
60354	4	3/4	31/2	1.231	3/8	11/8	37/8	60°	60°	3500	1165
60355	5	3/4	31/2	1.748	3/8	11/8	45/8	60°	60°	3500	1165