

Category 4, EN 954-1 PNOZ X2.3P



EMERGENCY STOP relay and safety gate monitor in accordance with VDE 0113 Part 1, 11/98 and EN 60204-1, 12/97

Features

- Dual-channel operation which detects shorts across the input contacts
- Supply voltage: 24 V AC/DC
- Automatic or monitored manual reset can be selected
- Plug-in connection terminals

Approval

| | PNOZ X2.3P |
|--|------------|
| | pending |
| | ● |
| | ● |

| Technical details | PNOZ X2.3P |
|--|---|
| Electrical data | |
| Supply voltage | AC: 24 V DC: 24 V |
| Tolerance | 85 ... 110 % |
| Power consumption | approx. 2 W/2 VA |
| Voltage and current at input, reset and feedback loop | 24 V DC/25 mA |
| Switching capability in accordance with EN 60947-4-1, 10/91 | AC1: 240 V/6 A/1500 VA DC1: 24 V/4 A/100 W |
| EN 60947-5-1, 10/91 (DC13: 6 switching cycles/min) | AC15: 230 V/5 A; DC13: 24 V/4A |
| Output contacts | 3 safety contacts (N/O), |
| Contact fuse protection to EN 60947-5-1, 10/91 | 6 A quick or 4 A slow |
| Times | |
| Delay-on energisation | automatic reset: max. 150 ms manual reset: max. 100 ms |
| Delay-on de-energisation | input circuit, single channel: max. 100 ms input circuit, dual-channel: max. 30 ms |
| Recovery time | approx. 1 s |
| Simultaneity channel 1/2 | ∞ |
| Supply interruption before de-energisation | approx. 10 ms |
| Mechanical data | |
| Max. cross section of external conductor | |
| Single-core conductor | flexible without crimp connector: 0,2 ... 2.5 mm ² flexible with crimp connector: 0.25 ... 2.5 mm ² |
| Multi-core conductor (2 conductors with identical cross section) | flexible with crimp connector without plastic sleeve: 0.25 ... 1 mm ² flexible with TWIN crimp connector with plastic sleeve: 0.5 ... 1.5 mm ² |
| Torque setting for terminals | 0.5 ... 0.6 Nm (screws) |
| Dimensions (H x W x D) | 94 x 22.5 x 121 mm |
| Weight | 200 g |

Description

- 22.5 mm P-99 housing, DIN-Rail mounting
- Positive-guided relay outputs: 3 safety contacts (N/O)
- Connections for
 - emergency stop button or safety gate limit switch
 - reset switch
- Detects shorts across the input contacts
- LED indicators for switching status, channel 1/2 and supply voltage
- Increase in the number of safety contacts available by connecting expander modules

Operating modes

- Single-channel operation
- Dual-channel operation
- Automatic reset
- Monitored manual reset

Category 4, EN 954-1 PNOZ X2.3P

Schematic internal wiring diagram

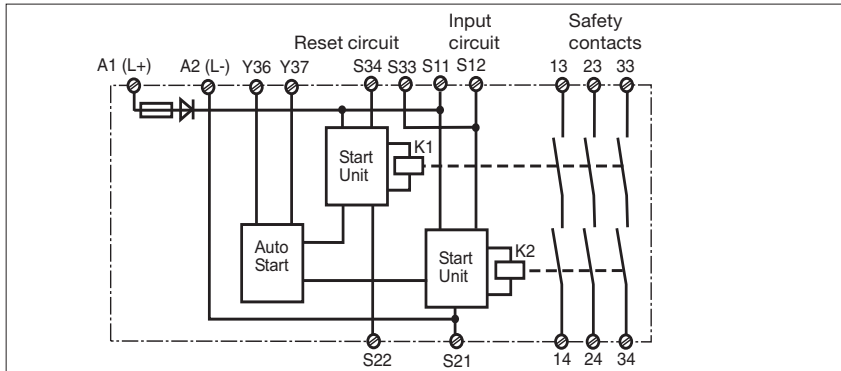

– Key

S1/S2: E-STOP or safety gate switch
S3: Reset button

↑ Switch operated

⬆ Gate open

⬆ Gate closed

External wiring

● Example 1
Single-channel E-Stop wiring with monitored manual reset

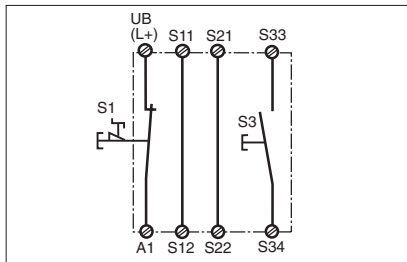

● Example 4
Dual-channel safety gate control with monitored manual reset

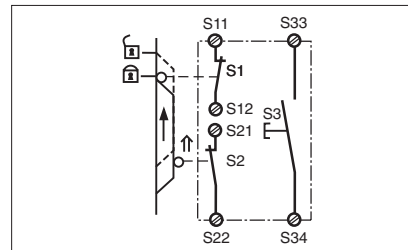

● Example 2
Dual-channel E-Stop wiring with monitored manual reset

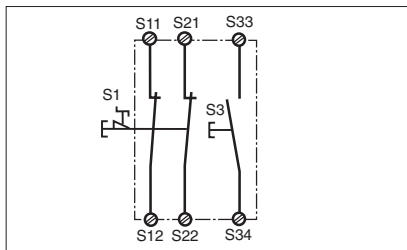

● Increase in the number of contacts
The number of output contacts can be increased by using expander modules or relays/contactors with positive-guided contacts.

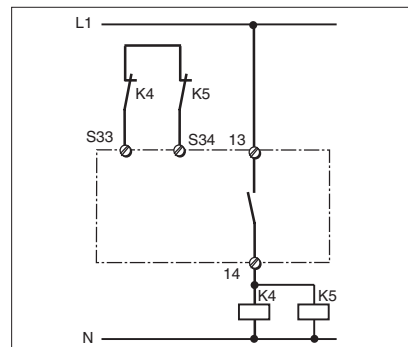

● Example 3
Dual-channel safety gate control with automatic reset

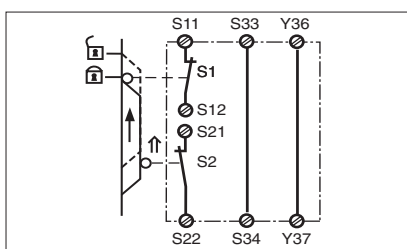

Category 4, EN 954-1 PNOZ X2.3P

General data

Unless stated otherwise in the technical details for the specific unit.

Electrical data

| | |
|--------------------|--------------------|
| AC frequency range | 50 ... 60 Hz |
| DC residual ripple | 160 % |
| Contact material | AgSnO ₂ |
| Continuous duty | 100 % |

Environmental data

| | |
|----------------------------------|--|
| EMC | EN 50081-1, 01/92, EN 50082-2, 03/95 |
| Vibration to EN 60068-2-6, 04/95 | Frequency: 10 ... 55 Hz, Amplitude: 0.35 mm |
| Climatic suitability | IEC 60068-2-3, 1969 |
| Airgap creepage | DIN VDE 01101, 04/97 |
| Ambient temperature | -10 ... +55 °C |
| Storage temperature | -40 ... +85 °C |

Mechanical data

| | |
|---|---|
| Torque setting for connection terminals | 0.6 Nm (screws) |
| Mounting position | Any |
| Housing material | Thermoplastic Noryl SE 100 |
| Protection type | Mounting: IP 54 Housing: IP 40 Terminals: IP 20 |