







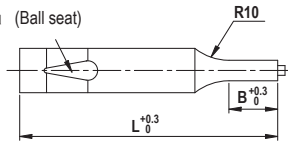

พินซ์บอลล็อก แบบเจคเตอร์ สำหรับงานทั่วไป (JECTOR BALL LOCK PUNCHES - LIGHT LOAD)

ชนิด (Type)	STEEL GRADE M HARDNESS H	Catalog No.			รูปร่างของปลายพินซ์เลือกจากรูป A E ตามภาพด้านล่าง (Tip shape can selected from A E in figure below)
		Type	B Point length	Shape	
-Economy type- รุ่นประหยัด 	SKD11 60-63HRC	PJL	S 		
-With groove for spanner- รุ่นมีร่อง (สำหรับประแจขัน) 		PJLG	L 		

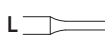
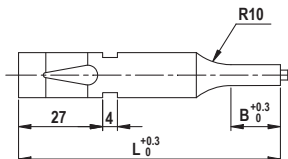
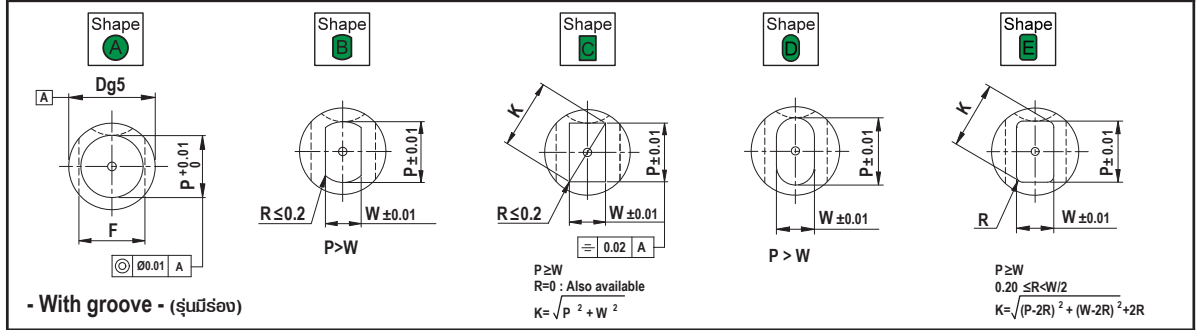
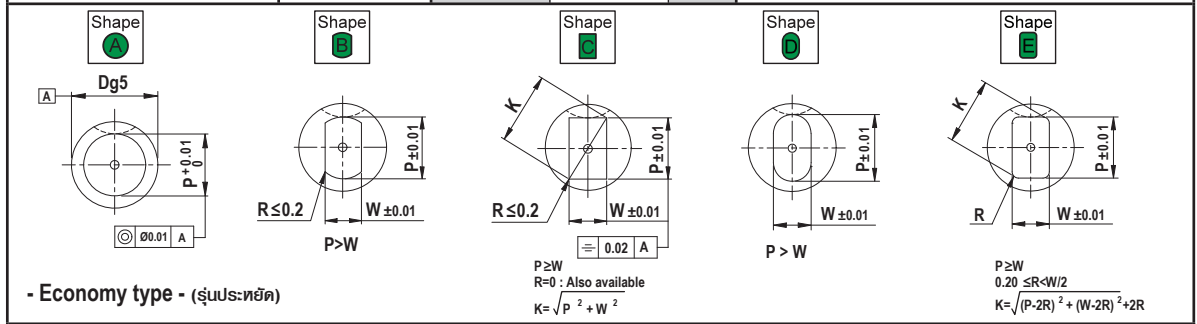

Catalog No.		ØD	L	0.01 mm.					B	F	
Type	S			A		B	C	D			E
				min. P	max.	P·Kmax.	P·Wmin.	R			
S PjLSA PjLGSA PjLSB PjLGSB PjLSC PjLGSC PjLSD PjLGSD PjLSE PjLGSE	10	63 71 74 80 90	3.00-9.97	9.90	3.00	0.20 ≤ R < W/2 (E only)	R	13	8		
	13		6.00-12.97	12.90	3.00						
	16		10.00-15.97	15.90	4.00						
	20		13.00-19.97	19.90	5.00						
	25		18.00-24.97	24.90	6.00						
	32		22.00-31.97	31.90	7.00						
	L PjLLA PjLGLA PjLLB PjLGLB PjLLC PjLGLC PjLLD PjLGLD PjLLE PjLGLE		10	71 74 80 90	3.00-9.97					9.90	3.00
13		6.00-12.97	12.90		3.00						
16		10.00-15.97	15.90		4.00						
20		13.00-19.97	19.90		5.00						
25		18.00-24.97	24.90		6.00						
32		22.00-31.97	31.90		7.00						

Order
 Catalog No. **PJLSE**
 ØD - **25** - L - **90** - P - **P20.00** - W - **W12.00** - R(**E**only)