

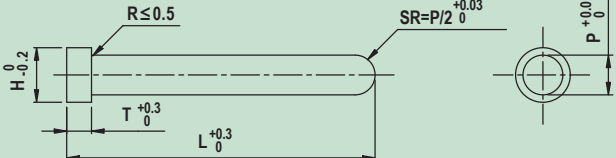



พื้นที่ขึ้นรูปปลายทรงกลม (EMBOSSING PUNCHES)

	<p>EMPB</p> 	<p>EMPB</p> <p>M SKH51</p> <p>H 61~64HRC</p>
	<p>EMPS</p> 	<p>EMPS</p> <p>M SKD11</p> <p>H 60~63HRC</p>
	<p>EMPT EMPT-H</p> 	<p>EMPT</p> <p>M SKD11</p> <p>H 60~63HRC</p> <p>EMPT-H</p> <p>M SKH51</p> <p>H 61~64HRC</p>

Catalog No.		0.1mm.	0.01mm.	H	T	ราคาบาท/ชิ้น (Baht/Piece)
Type	No.	L	min. P max.			
EMPB	3	20.0~80.0	2.50 ~ 3.00	5	5	280
	4		3.00 ~ 4.00	7		285
	5		4.00 ~ 5.00	8		290
	6		5.00 ~ 6.00	9		295
	8		6.00 ~ 8.00	11		320
	10		8.00 ~ 10.00	13		355

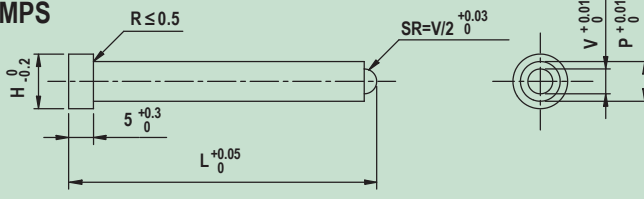
Catalog No.		0.1mm.	0.01mm.	H	ราคาบาท/ชิ้น (Baht/Piece)	
Type	No.	L	min. P max.	V		
EMPS	3	20.0~80.0	2.00~3.00	P/2 ≤ V < P	5	340
	4		3.00~4.00		7	350
	5		4.00~5.00		8	355
	6		5.00~6.00		9	355
	8		6.00~8.00		11	385
	10		8.00~10.00		13	410

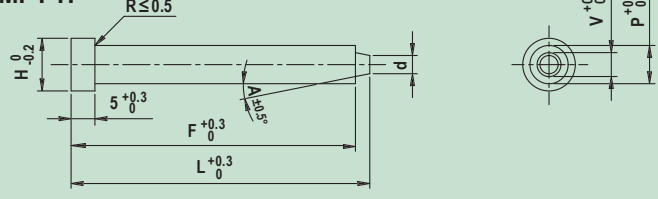
Catalog No.		0.1mm.	0.01mm.	1°	0.1mm.	H	ราคาบาท/ชิ้น (Baht/Piece)		
Type	No.	L	min. P max.	V	A	F	EMPT	EMPT-H	
EMPT	3	20.0~80.0	2.00~3.00	P/2 ≤ V < P-0.6	0 < A < 90	F ≤ L-2	5	415	450
	4		3.00~4.00				7	420	465
EMPT-H	5		4.00~5.00				8	425	470
	6		5.00~6.00				9	430	475
	8		6.00~8.00				11	495	530
	10		8.00~10.00				13	530	560

● อัตราส่วนลดตามปริมาณการสั่งซื้อ (Volume discount rate)

ปริมาณ / ชิ้น Quantity / Unit	1~9	10~29	30~99	100~
ส่วนลด Discount rate	-	5%	10%	20%



Order

Catalog No.

EMPS 3

L - P - V

40 - P2.80 - V1.50

● ระยะเวลาในการผลิต 3 วันทำงาน

● ราคาและระยะเวลาในการจัดส่ง จะขึ้นอยู่กับปริมาณการสั่งซื้อ