

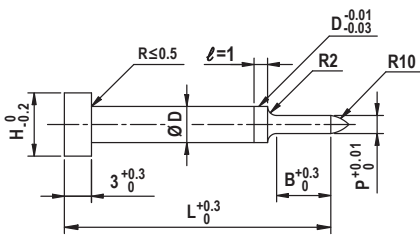





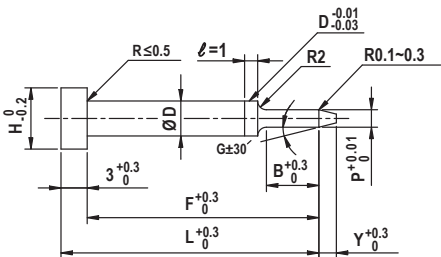

พาลอตฟันช์ ชนิดยึดที่แผ่นสตริปเปอร์ (PILOT PUNCHES - FIXED IN STRIPPER PLATE)

ชนิด (Type)	ลำตัวฟันช์ (Shank dia.) ØD	STEEL GRADE M HARDNESS H	Catalog No.	Views						
-Tip R type- ปลายมน 	Dm5	SKD11 60~63HRC	PPST							
		HAP40 64~67HRC	PPPST							
	D ^{+0.005} ₀	SKD11 60~63HRC	A-PPST							
		HAP40 64~67HRC	A-PPPST							
-Tip tapered type- ปลายทapers 	Dm5	SKD11 60~63HRC	PTST	 <table border="1" data-bbox="1155 813 1274 891"> <tr> <td>P</td> <td>G</td> </tr> <tr> <td>1.00~1.99</td> <td>10°</td> </tr> <tr> <td>2.00~</td> <td>15°</td> </tr> </table>	P	G	1.00~1.99	10°	2.00~	15°
		P	G							
	1.00~1.99	10°								
	2.00~	15°								
HAP40 64~67HRC	PPTST									
D ^{+0.005} ₀	SKD11 60~63HRC	A-PTST								
	HAP40 64~67HRC	A-PPTST								
-Tip acute-angle type- ปลายแหลม 	Dm5	SKD11 60~63HRC	PAST							
		HAP40 64~67HRC	PPAST							
	D ^{+0.005} ₀	SKD11 60~63HRC	A-PAST							
		HAP40 64~67HRC	A-PPAST							

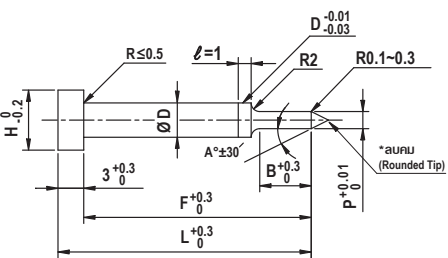
Catalog No.		L	P	A	B	Y	H
ชนิด (Type)	NO.	▲ 0.1mm.	▲ 0.01mm.				
SKD11	3	10.0~40.0	1.00~2.99	(10) 15 20 25 30	4 [If L ≤ 12 B = 2]	2	5
PPST A - PPST	4		2.00~3.99				7
PTST A - PTST	5		2.00~4.99			8	
PAST A - PAST	6		2.50~5.99			9	
HAP40	8		5.00~7.99			11	
PPPST A - PPPST	10		7.00~9.99			13	
PPTST A - PPTST							
PPAST A - PPAST							



Order

Catalog No.	-	L	-	P	-	A
PPST 3	-	28.0	-	P2.48	-	
PAST 4	-	32.0	-	P3.50	-	A15

หมายเหตุ : ถ้าค่า P>D-0.03 จะไม่มีการเจียรตกหลุม ØD^{-0.01}_{-0.03} (When P>D-0.03, there will be no grinding relief of ØD^{-0.01}_{-0.03})
 ถ้า L ≤ 12 mm. ค่า B จะเป็น 2 เท่านั้น (When L ≤ 12 mm., "B" value will be 2 uniformly)
 A(10) มีเฉพาะ P < 2.00, ถ้า P ≥ 2.00 A = 10 จะไม่มี (When P < 2.00, "A" will be = 10 uniformly)