

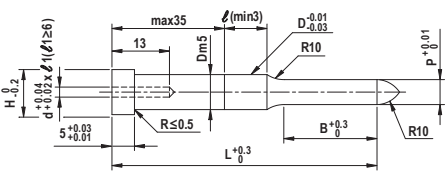





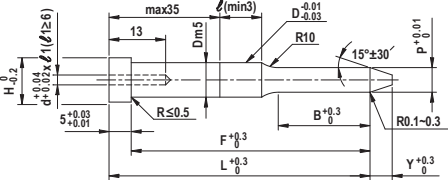

พาลอตพUNCH มิดกลาง (PILOT PUNCHES WITH CENTER HOLE)

ชนิด (Type)	ลำตัวพUNCH (Shank dia.) ØD	STEEL GRADE M HARDNESS H	Catalog No.	Views
-Tip R type- ปายมม 	Dm5	SKD11 60-63HRC	PPSA-C PPLA-C PPXA-C	 A DPS6-25
-Tip tapered type- ปายเทเปอร์ 	Dm5	SKD11 60-63HRC	PTSA-C PTLA-C PTXA-C	 A DPS6-25

Catalog No. ชนิด (Type)	ØD	L	P 0.01 mm.	B	H	Y
ค่า B สั้น (Short)  PPSA-C PTSA-C	10	(42) 52 62 72 82 92 102	3.00~9.99	15	13	5
	13		6.00~12.99		16	
	16		10.00~15.99	[if L = (42) B = 10]	19	8
	20		13.00~19.99		23	
	25		18.00~24.99		28	
ค่า B ยาว (Long)  PPLA-C PTLA-C	10	52 62 72 82 92 102	3.00~9.99	21	13	5
	13		6.00~12.99		16	
	16	62 72 82 92 102	10.00~15.99	27	19	8
	20		13.00~19.99		23	
	25		18.00~24.99		28	
ค่า B ยาวพิเศษ (Extra Long)  PPXA-C PTXA-C	10	62 72 82 92 102	3.00~9.99	32	13	5
	13		6.00~12.99		16	
	16	72 82 92 102	10.00~15.99	42	19	8
	20		13.00~19.99		23	
	25		18.00~24.99		28	



Order

Catalog No.

ØD

L

P

PPSA-C

10

- 72

-

P8.50

หมายเหตุ : ถ้าค่า P>D-0.03 จะไม่มีการเจียรถกหลบ ØD^{+0.01}_{-0.03} (When P>D-0.03, there will be no grinding relief of ØD^{+0.01}_{-0.03})
ถ้า L = (42) ค่า B จะเป็น 10 เท่านั้น (When L = (42), "B" value will be 10 uniformly)