

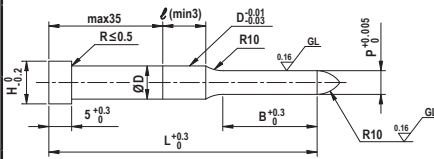





# พาลอตพันช์ แบบทิวขัดมัน (PILOT PUNCHES - LAPPING TYPE)

ชนิด (Type)	ลำตัวพันช์ (Shank dia.) ØD	STEEL GRADE M HARDNESS H	Catalog No.	Views
-Tip R type- ปาลายนูน 	Dm5	SKD11 60-63HRC	L-PPSA L-PPLA L-PPXA	
		HAP40 64-67HRC	L-PPPSA L-PPPLA L-PPPPXA	
	D <sup>+0.005</sup> <sub>0</sub>	SKD11 60-63HRC	AL-PPSA AL-PPLA AL-PPXA	
		HAP40 64-67HRC	AL-PPPSA AL-PPPLA AL-PPPPXA	
-Tip tapered type- ปาลายทapers 	Dm5	SKD11 60-63HRC	L-PTSA L-PTLA L-PTXA	
		HAP40 64-67HRC	L-PPTSA L-PPTLA L-PPTXA	
	D <sup>+0.005</sup> <sub>0</sub>	SKD11 60-63HRC	AL-PTSA AL-PTLA AL-PTXA	
		HAP40 64-67HRC	AL-PPTSA AL-PPTLA AL-PPTXA	

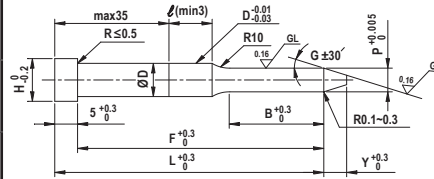
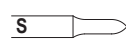
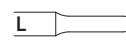
P	G
P ≤ 1.99	10°
P ≥ 2.00	15°

Catalog No. ชนิด (Type)	ØD	L			P 0.01mm.	B	H	Y				
<b>คำ B สั้น (Short)</b>  <b>S</b> (Dm5) (D <sup>+0.005</sup> <sub>0</sub> )	3	42	52	62	72	1.00-2.99	10	5	2			
	4	42	52	62	72	1.00-3.99		7				
	5	42	52	62	72	2.00-4.99		8				
	<b>SKD11</b> L-PPSA AL-PPSA L-PTSA AL-PTSA <b>HAP40</b> L-PPPSA AL-PPPSA L-PPTSA AL-PPTSA	6	42	52	62	72	2.50-5.99	9	3			
		8	(42)	52	62	72	82	92		3.00-7.99	11	
		10	(42)	52	62	72	82	92	102	3.00-9.99	13	5
		13	(42)	52	62	72	82	92	102	6.00-12.99	16	
		16	(42)	52	62	72	82	92	102	10.00-15.99	19	
		20	(42)	52	62	72	82	92	102	13.00-19.99	23	
		25	(42)	52	62	72	82	92	102	18.00-24.99	28	
<b>คำ B ยาว (Long)</b>  <b>L</b> (Dm5) (D <sup>+0.005</sup> <sub>0</sub> )		3	52	62	72	1.00-2.99	15	5	2			
		4	52	62	72	1.00-3.99		7				
		5	52	62	72	2.00-4.99		8				
	<b>SKD11</b> L-PPLA AL-PPLA L-PTLA AL-PTLA <b>HAP40</b> L-PPPLA AL-PPPLA L-PPTLA AL-PPTLA	6	52	62	72	2.50-5.99	9	3				
		8	52	62	72	82	92		3.00-7.99	11		
		10	52	62	72	82	92	102	3.00-9.99	13	5	
		13	52	62	72	82	92	102	6.00-12.99	16		
		16	62	72	82	92	102	10.00-15.99	19			
		20	62	72	82	92	102	13.00-19.99	23			
		25	62	72	82	92	102	18.00-24.99	28			
<b>คำ B ยาวพิเศษ (Extra Long)</b>  <b>X</b> (Dm5) (D <sup>+0.005</sup> <sub>0</sub> )		3	52	62	72	1.20-2.99	21	5	2			
		4	52	62	72	1.20-3.99		7				
		5	62	72	2.00-4.99	8						
	<b>SKD11</b> L-PPXA AL-PPXA L-PTXA AL-PTXA <b>HAP40</b> L-PPPPXA AL-PPPPXA L-PPTXA AL-PPTXA	6	62	72	2.50-5.99	9	27	9	3			
		8	62	72	82	92		3.00-7.99		11		
		10	62	72	82	92	102	3.00-9.99	13	5		
		13	62	72	82	92	102	6.00-12.99	16			
		16	72	82	92	102	10.00-15.99	19				
		20	72	82	92	102	13.00-19.99	23				
		25	72	82	92	102	18.00-24.99	28				



**Order**

**Catalog No.**

**ØD**

**- L -**

**P**

AL-PPTSA

6

- 52 -

P4.97

หมายเหตุ: ถ้าค่า P>D-0.03 จะไม่มีการเจียรถกหลบ ØD<sub>0.03</sub><sup>0.01</sup> (When P>D-0.03, there will be no grinding relief of ØD<sub>0.03</sub><sup>0.01</sup>)

ถ้า L = (42) คำ B จะเป็น 10 เท่านั้น (When L = (42), "B" value will be 10 uniformly)