





โครงสร้างแบบมีร่องโดเวล (BUTTON DIES - DOWEL SLOT TYPE)



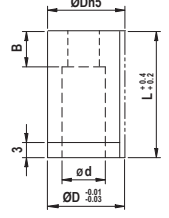

M SKD11
H 60~63 HRC

BSA-W
BSB-W
BSC-W
BSD-W
BSE-W

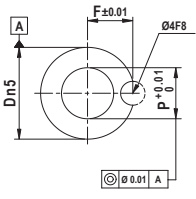

Shape 
BSA-W



Shape 
BSB-W

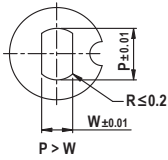

Shape 
BSC-W

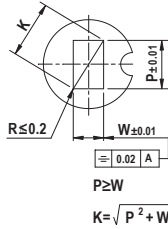

Shape 
BSD-W

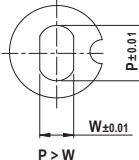

Shape 
BSE-W

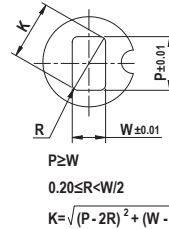

Dn5	Catalog No.	ØD	L	0.01 mm.					B	Ød	F
				(A)	B	C	D	E			
ชนิด (Type)				min. P max.	P·Kmax.	P·Wmin.	R				
10	BSA-W	10	16 20 22 25 30 35	2.00~6.00	6.00	1.20	0.20 ≤ R < W/2 (E only)	6	6.4	6	
13		13	16 20 22 25 30 35	3.00~8.00	8.00	1.50		8	8.4	7.5	
16	BSB-W	16	16 20 22 25 30 35	5.00~10.00	10.00	2.00		8	10.6	8	
20		20	16 20 22 25 30 35	7.00~12.00	12.00	3.00		8	12.6	10	
25	BSC-W	25	16 20 22 25 30 35	10.00~16.00	16.00	3.00		8	16.6	12.5	
32		32	16 20 22 25 30 35	15.00~20.00	20.00	4.00		8	20.6	16	
38	BSD-W	38	16 20 22 25 30 35	19.00~26.00	26.00	5.00		8	26.6	19	
45		45	20 22 25 30 35	25.00~35.00	35.00	6.00		8	36.0	22.5	
50	BSE-W	50	20 22 25 30 35	33.00~40.00	40.00	7.00		8	41.0	25	
56		56	20 22 25 30 35	38.00~45.00	45.00	8.00		8	46.0	28	

Order

 Catalog No. ØD - L - P - W - R(E only)

 BSE-W 13 - 20 - P6.00 - W2.40 - R1.00

B ราคา บาท/ชิ้น (Baht/Piece)





ØD	BSA-W	BSB-W BSD-W	BSC-W BSE-W
10	226		763
13	207		794
16	207		838
20	226		885
25	283		947
32	350		997
38	704		1,568
45	1,529		3,146
50	1,837		3,531
56	2,244		3,933

● อัตราส่วนลดตามปริมาณการสั่งซื้อ (Volume discount rate)

ปริมาณ / ชิ้น Quantity / Unit	1~9	10~29	30~99	100~
ส่วนลด Discount rate	-	5%	10%	20%

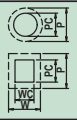
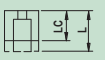
- ระยะเวลาในการผลิต 3 วันทำงาน
- ราคาและระยะเวลาในการจัดส่ง จะขึ้นอยู่กับปริมาณการสั่งซื้อ

ค่าบริการเพิ่มเติมในการเปลี่ยนค่าต่างๆ (Extra Charges For Alterations)

ลักษณะการเปลี่ยนแปลง (Alterations)	Code การส่ง	(A) (ไดนา)	B C D E (ไดรูปร่าง)	ค่าบริการ/ชิ้น(บาท) (Baht/Piece)
	PC WC	$\min : P > PC \geq P \cdot W_{\min} \geq 1.20$ $\frac{W}{WC} \geq 2$ $\uparrow 0.01 \text{ mm.}$ $\max : P < PC \leq P \cdot K_{\max} + 0.2$ $\frac{W}{WC}$ $\uparrow 0.01 \text{ mm.}$		40
เจาะรูความยาวให้สั้นกว่ามาตรฐาน 	LC	$10 \leq LC < L$ $\uparrow 0.1 \text{ mm.}$		40
เปลี่ยนองศามุมล็อก 	KC	—	180° 270° 90° $\uparrow 1^\circ$	40
เจาะค่า P ให้มีค่าพิกัดน้อยลง 	PKC	$P \pm 0.01 \rightarrow \begin{matrix} +0.005 \\ 0 \end{matrix}$	$P \cdot W \pm 0.01 \rightarrow \begin{matrix} +0.01 \\ 0 \end{matrix}$	80
เจาะรูความยาวให้มีค่าพิกัดน้อยลง 	LKC	$L \pm 0.4 \rightarrow \begin{matrix} +0.05 \\ 0 \end{matrix}$ $\uparrow 0.2$ * L < 16 ไม่มี (Not available)		80