

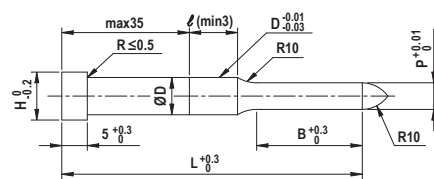





ชนิด (Type)	ลำตัวปันช์ (Shank dia.) ØD	STEEL GRADE M HARDNESS H	Catalog No.	Views
-Tip R type- ปายมูน 	Dm5	SKD11 60-63HRC	PPSA PPLA PPXA	
		HAP40 64-67HRC	PPPSA PPPLA PPPPXA	
	D $\begin{matrix} +0.005 \\ 0 \end{matrix}$	SKD11 60-63HRC	A-PPSA A-PPLA A-PPXA	
		HAP40 64-67HRC	A-PPPSA A-PPPLA A-PPPPXA	
-Tip tapered type- ปายเทเปอร์ 	Dm5	SKD11 60-63HRC	PTSA PTLA PTXA	
		HAP40 64-67HRC	PPTSA PPTLA PPTXA	
	D $\begin{matrix} +0.005 \\ 0 \end{matrix}$	SKD11 60-63HRC	A-PTSA A-PTLA A-PTXA	
		HAP40 64-67HRC	A-PPTSA A-PPTLA A-PPTXA	

Catalog No.	ØD	L				P 0.01mm.	B	H	Y		
คำ B สั้น (Short)  S (Dm5) (D $\begin{matrix} +0.005 \\ 0 \end{matrix}$) SKD11 PPSA A-PPSA PTSA A-PTSA HAP40 PPPSA A-PPPSA PPTSA A-PPTSA	3	42	52	62	72	1.00-2.99	10	5	2		
	4	42	52	62	72	1.00-3.99		7			
	5	42	52	62	72	2.00-4.99		8	3		
	6	42	52	62	72	2.50-5.99		9			
	8	(42)	52	62	72	82	92	3.00-7.99	11	5	
	10	(42)	52	62	72	82	92	102	3.00-9.99		13
	13	(42)	52	62	72	82	92	102	6.00-12.99	16	
	16	(42)	52	62	72	82	92	102	10.00-15.99	19	8
	20	(42)	52	62	72	82	92	102	13.00-19.99	23	
	25	(42)	52	62	72	82	92	102	18.00-24.99	28	
	คำ B ยาว (Long)  L (Dm5) (D $\begin{matrix} +0.005 \\ 0 \end{matrix}$) SKD11 PPLA A-PPLA PTLA A-PTLA HAP40 PPPLA A-PPPLA PPTLA A-PPTLA	3	52	62	72	1.00-2.99	15	5	2		
		4	52	62	72	1.00-3.99		7			
5		52	62	72	2.00-4.99	8		3			
6		52	62	72	2.50-5.99	9					
8		52	62	72	82	92	3.00-7.99	11	5		
10		52	62	72	82	92	102	3.00-9.99		13	
13		52	62	72	82	92	102	6.00-12.99	16		
16		62	72	82	92	102	10.00-15.99	19	8		
20		62	72	82	92	102	13.00-19.99	23			
25		62	72	82	92	102	18.00-24.99	28			
คำ B ยาวพิเศษ (Extra Long)  X (Dm5) (D $\begin{matrix} +0.005 \\ 0 \end{matrix}$) SKD11 PPXA A-PPXA PTXA A-PTXA HAP40 PPPXA A-PPPPXA PPTXA A-PPTXA		3	52	62	72	1.20-2.99	21	5	2		
		4	52	62	72	1.20-3.99		7			
	5	62	72	2.00-4.99	8	3					
	6	62	72	2.50-5.99	9						
	8	62	72	82	92	3.00-7.99	11	5			
	10	62	72	82	92	102	3.00-9.99		13		
	13	62	72	82	92	102	6.00-12.99	16			
	16	72	82	92	102	10.00-15.99	19	8			
	20	72	82	92	102	13.00-19.99	23				
	25	72	82	92	102	18.00-24.99	28				

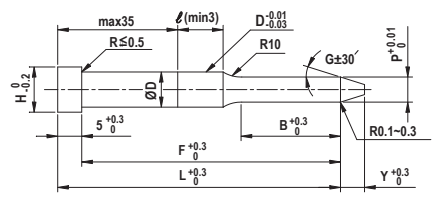

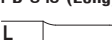
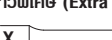
Order

Catalog No.

ØD

L

P

A-PPSA

8

- 82

- P5.02

หมายเหตุ : ถ้าค่า P>D-0.03 จะไม่มีการเจียรตัดหลบ ØD $\begin{matrix} 0.01 \\ 0.03 \end{matrix}$ (When P>D-0.03, there will be no grinding relief of ØD $\begin{matrix} 0.01 \\ 0.03 \end{matrix}$)
 ถ้า L = (42) ค่า B จะเป็น 10 เท่านั้น (When L = (42), "B" value will be 10 uniformly)