

# 4.3 Tank Agitators and Mixers

For mixing or stirring your products.



### PD Sheets

Alfa Laval MM UltraPure, Magnetic Mixer	4.3.1030
Side mounted agitators Type ALS	4.3.1033
Top mounted agitators, type ALT	4.3.1036
Top mounted agitators, type ALTB	4.3.1039
Bottom mounted agitators Type ALB	4.3.1042
IM 10 Rotary Jet Mixer	4.3.1045
IM 15 Rotary Jet Mixer	4.3.1047
IM 20 Rotary Jet Mixer	4.3.1049
IM 25 Rotary Jet Mixer	4.3.1051

### Ordering Leaflets

Alfa Laval MM UltraPure, Magnetic Mixer	4.3.1053
Tools and spare parts for Alfa Laval MM UltraPure, Magnetic Mixer	4.3.1054
Range of Agitators	4.3.1055
ALS, 50 Hz, 0-10 cP	4.3.1056
ALS, 50 Hz, 10-50 cP	4.3.1058
ALS, 60 Hz, 0-10 cP	4.3.1059
ALS, 60 Hz, 10-50 cP	4.3.1061
ALS - Side Mounted Agitator	4.3.1062
IM 10 Rotary Jet Mixer	4.3.1066
IM 15 Rotary Jet Mixer	4.3.1067
IM 20 Rotary Jet Mixer	4.3.1068
IM 25 Rotary Jet Mixer	4.3.1069

# Levitated Magnetic Mixer

Alfa Laval MM UltraPure, Magnetic Mixer

**Application**

Alfa Laval magnetic mixers offer effective mixing for applications with high demands on hygienic and aseptic design.

**Working principle**

The patented levitated bearing makes the mixer fully drainable and able to run dry without wear or particle generation. The performance ranges from low shear mixing at around 10 rpm to high intensity mixing with vortex at up to 600 rpm. For mixing tasks the range covers from 30 liters to 25000 liters of nominal batch size.

**Standard design**

The Alfa Laval MM UltraPure mixer consists of a weld plate and a mixer unit incl. gear drive. The weld plate is ordered and delivered separately to enable early preparation of the mixer installation. The mixer must be controlled by a VFD unit matched perfectly with the mixer as available in the ordering leaflet. The VFD is pre-programmed for optimum performance.



**TECHNICAL DATA**

Product wetted surface finish: . . . . . Ra <0.5 µm Mech. polish  
 Option: . . . . . Ra <0.5 µm and Electro polished  
 Working pressure: . . . . . -1 to 7 bar (g)

**Voltage and frequency**

AC motors: . . . . . 3x205/355V, 50Hz  
 AC VFD: . . . . . 240/120 V, 48-62Hz

**Protection class**

AC motors: . . . . . IP66  
 AC VFD stand alone: . . . . . IP66  
 AC VFD enclosure unit: . . . . . IP20

**Motor sizes**

MM 338-4/6: . . . . . 0.37 kW  
 MM 434-8/10/12: . . . . . 1.1 kW

**Certificates**

Standard delivery includes:

- 3.1 Materials Certificates, EN10204 for all product wetted parts
- USP Class VI <88> certificates for Zirconia YTZP and ISOLAST 9501
- FDA Declaration of conformity for elastomers and ceramics
- USDA-H1 conformity statement (FDA) for gear drive oil
- TSE declaration (Transmissible Spongiform Encephalopathy) / ADI declaration (Animal Derived Ingredients)
- USP Class VI <88> certificates on request for Silicon Carbide parts

**PHYSICAL DATA**

**Materials**

Impeller and Weld Plate: . . . . . AISI 316L (UNS S31603)  
 Drive rotor and distance piece: . . . . . AISI 316L (UNS S31603)  
 Motor and Gearbox: . . . . . ANSI / NSF 51 compliant paint  
 Male Bearing: . . . . . Zirconia YTZP  
 Male Bearing Gasket: . . . . . ISOLAST 9501 (Perfluoro Elastomer)  
 Female Bearing: . . . . . Silicone Carbide  
 Gearbox oil: . . . . . USDA-H1

**Temperature**

Product mixing (10 – 600 rpm): . . . . . max. 90°C  
 CIP (max 50 rpm): . . . . . max. 95°C  
 SIP (0 rpm): . . . . . max. 150°C

**Weight**

MM 338: . . . . . 12 kg  
 MM 434: . . . . . 30 kg

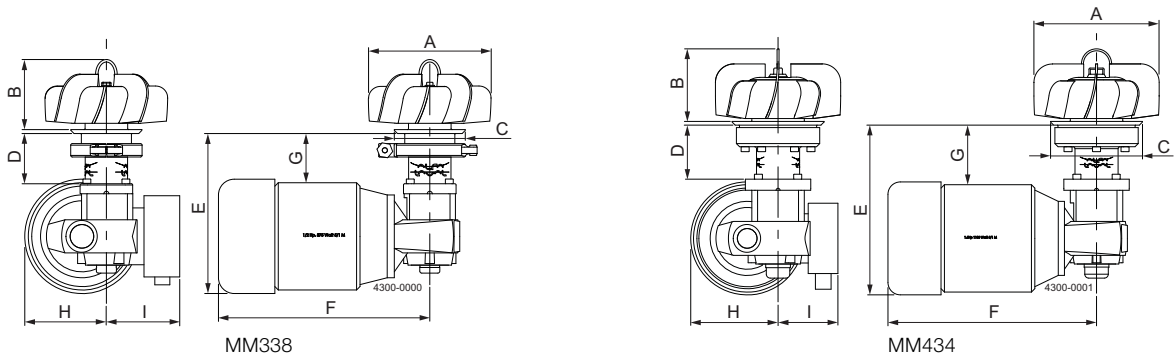
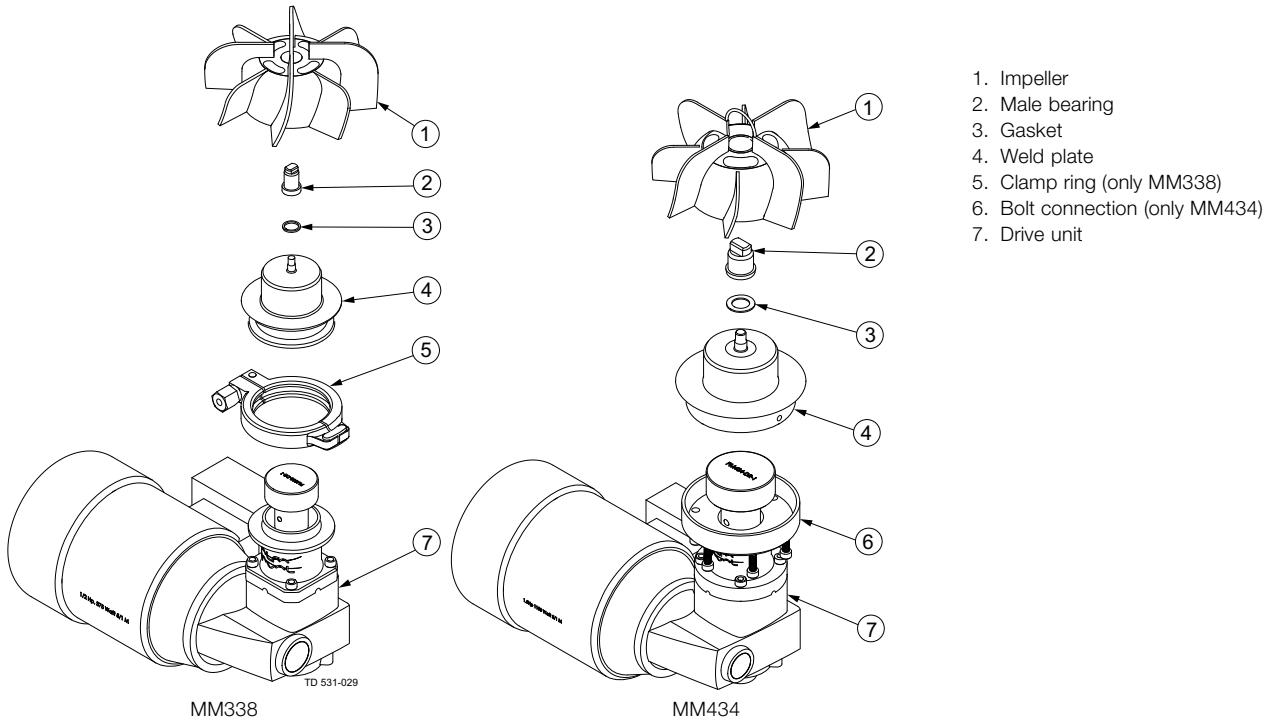

Dimensions (mm)	MM 338-4	MM 338-6	MM 434-8	MM 434-10	MM 434-12
A	102	155	203	254	305
B	89	89	118	183	183
C	90	90	149	149	149
D	64	64	88	88	88
E	203	203	275.1	275.1	275.1
F	268	268	338	338	338
G	62.5	62.5	96.6	96.6	96.6
H	103.5	103.5	141.5	141.5	141.5
I	93	93	97	97	97

**Machine Selection**

This chart is valid for machine selection under the following conditions:

- Liquid / liquid mixing
- Mixture viscosity less than 500 cP
- Tank height to diameter ratio (h/d) between 1 and 1.5

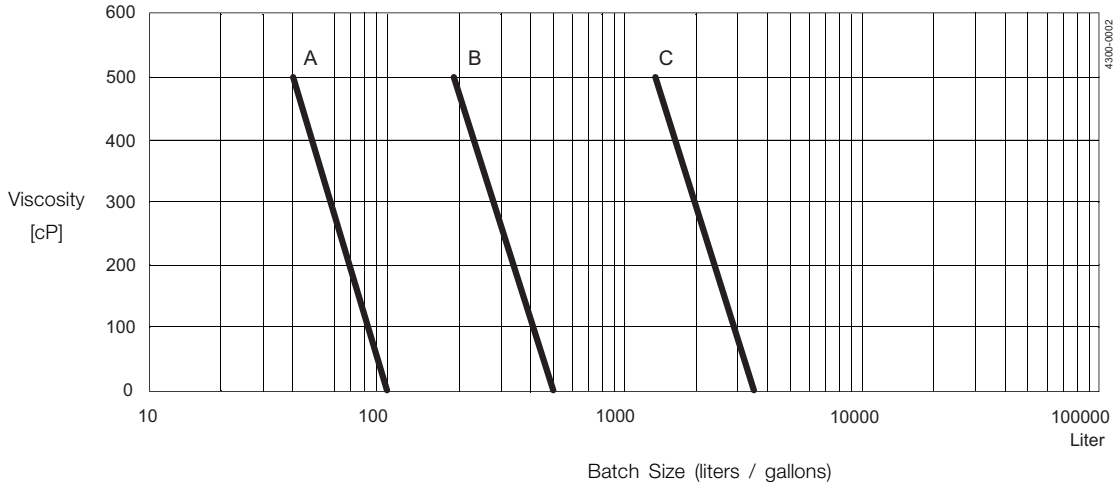

\*Gentle product treatment  
 \*\* Very gentle product treatment

A	B	C
MM 338-4 600 RPM	MM 338-6 550 RPM	MM 434-12 125 RPM
		MM 434-10 185 RPM
		MM 434-8 390 RPM



# Efficient Mixing and Agitation

## Side mounted agitators Type ALS

### Application

Application	Typical examples
Maintain media homogeneous	Milk storage tanks, cream tanks, mixed product tanks, UHT product storage tanks, etc.
Mixing and Solutions (dissolves)	Fluid and fluid mixing, i.e. drinking yoghurt and fruit mix tanks, flavoured milk mix tanks, syrup mix tanks, etc.
Solid Dispersion	Powder protein + oil mix tanks, micro salt + milk product mix tanks, etc.
Suspension	Fluids with particles, i.e. juice tanks, crystallising tanks etc.
Heat transmission	Circulation of media in tanks with dimple jacket (cooling or heating)
Dairy Fermentation (break coagula + mixing)	Yoghurt tanks, cheese culture tanks, crème fraîche, etc.



### TECHNICAL DATA

#### Motor

Motor size and speed as required for duty.  
As standard with IEC motor IP55, other types on request. As standard painted RAL5010.

#### Voltage and frequency

As standard for 3x380 to 420V, 50Hz - 3x440V to 480V, 60Hz  
All motor voltages and frequencies are available.

#### Gears

Different gear types available according to configuration.  
As standard filled with normal synthetic or mineral oil, optional: Food approved oil. As standard painted RAL5010.

#### Ordering

The following information is required to ensure correct sizing and configuration for ordering:

- Tank geometry
- Product properties
- Task of agitator
- Enquiry forms are available

### PHYSICAL DATA

#### Materials

Available materials:

Steel parts: . . . . . AISI 316L (standard)  
 AISI 304  
 AISI 904L  
 SAF 2205  
 Other materials on request.

Seal rubber parts

(O-rings or bellows): . . . . . EPDM  
 FPM/FEP (only for stationary o-rings)  
 FPM  
 Other materials on request.

Mechanical seal parts: . . . . .

Carbon  
 Carbon (FDA)  
 Silicon carbide

#### Certificates

3.1 Material certificates/FDA conformity statement according to 21 CFR177 on steel/elastomer parts in contact with media

#### Dimensions

Propeller standard diameter range:  $\varnothing$ 125 mm to 1900 mm. Specific dimensions on the drive unit and propeller(s) will depend on the actual configuration selected.



**Standard design**

The Alfa Laval range of side mounted propeller agitators is designed to meet almost every customer requirement. Due to their modular build, the agitators can be designed for every kind of application within the sanitary industry. The modular construction is designed with the aim to meet both European and American standards and regulations, such as EHEDG, USDA, FDA, 3A etc.

**Configurable design**

Type ALS agitator design is fully configurable divided in the following elements:

- Drives (drive + shaft support + shaft diameter)
- Seal arrangements (oil trap + shaft seal type)
- Shaft (length)
- Energy Saving Foils (propeller type + surface finish)
- Options

Each element has a broad range of different characteristics which makes it possible to size the agitator for all applications and requirements.

**Advantageous and profitable design**



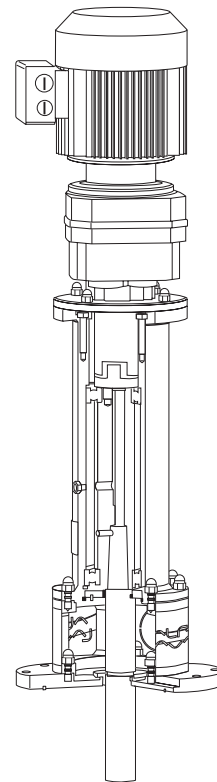



Each configuration offers a number of advantages, which are shown in the examples below:

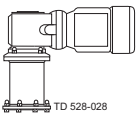
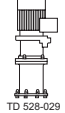
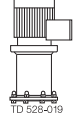
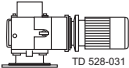
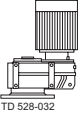
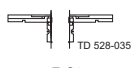
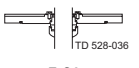
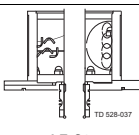
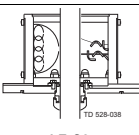
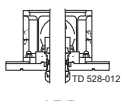
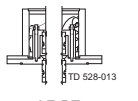
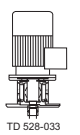

Operation features	Due to
Low energy consumption	the wide range of high efficiency propellers and drive units makes it possible to design for low operational costs
Gentle product treatment	the wide range of high efficiency propellers makes it possible to design for low shear operation

Sanitary features	Due to
Easy external cleaning	stainless steel bearing frame design with O-ring seal (for wash down)
Connections inside the tank (risk zones) can be avoided	bearing frame drives with drive shaft and special internal shaft connection without having a flange coupling inside the tank
Good drip off properties	no plane surfaces or grooves on internal parts
Easy cleaning	no interior shadow sides between the blades and smooth surfaces

Maintenance features	Due to
All service (replacement of wear parts such as shaft seals, bearings etc.) can be done from outside of the tank	bearing frame drives with detachable shaft which can be dismantled from outside of the tank
Easy dismantling	use of spider type coupling and stainless steel parts (no corrosion)

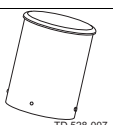
Type ALS	Configuration						Side mounted agitators
<p><b>Drives</b></p> <p>Bearing frame size = xx Shaft diameter = yy (not used if xx = yy)</p>  <p>TD 528-028</p>  <p>TD 528-029</p>  <p>TD 528-019</p>  <p>TD 528-031</p>  <p>TD 528-032</p> <p><b>-ME-GR-Bxx(yy)</b> Stainless steel bearing frame and right angle gearbox</p> <p><b>-ME-GC-Bxx(yy)</b> Stainless steel bearing frame and coaxial gearbox</p> <p><b>-ME-Bxx(yy)</b> Stainless steel bearing frame and direct motor drive</p> <p><b>-ME-GR-yy</b> Right angle gearbox, shaft mounted in hollow shaft of gearbox</p> <p><b>-ME-GP-yy</b> Parallel shaft gearbox, shaft mounted in hollow shaft of gearbox</p>							
<p>Description (power, speed and shaft diameter depending on application)</p>							
<p><b>Seal arrangements</b></p> <p>Description (lower flange and seal material depending on application)</p>	 <p>TD 528-035</p> <p><b>F-S1-</b> Seal flange with O-ring seal against tank flange, drain, oil trap (only geared versions) and shaft seal: single mechanical bellow seal</p>	 <p>TD 528-036</p> <p><b>F-S2-</b> Seal flange with O-ring seal against tank flange, drain, oil trap (only geared versions) and shaft seal: single mechanical non-bellow seal</p>	 <p>TD 528-037</p> <p><b>LF-S1-</b> Lantern (spacer), seal flange with O-ring seal against tank flange, drain, oil trap (only geared versions) and shaft seal: single mechanical bellow seal</p>	 <p>TD 528-038</p> <p><b>LF-S2-</b> Lantern (spacer), seal flange with O-ring seal against tank flange, drain, oil trap (only geared versions) and shaft seal: single mechanical non-bellow seal</p>	 <p>TD 528-012</p> <p><b>LF-D-</b> Lantern (spacer), seal flange with O-ring seal against tank flange, drain, oil trap and shaft seal: double mechanical seal for high pressure applications and aseptic use</p>	 <p>TD 528-013</p> <p><b>LF-DT-</b> Lantern (spacer), seal flange with O-ring seal against tank flange, drain, oil trap and shaft seal: double mechanical seal (tandem) for low pressure applications</p>	 <p>TD 528-033</p> <p><b>-ME-yyLF-S1-</b> Direct motor drive, shaft connected directly to motor, lantern (spacer), seal flange with O-ring seal against tank flange, drain and shaft seal: single mechanical bellow seal</p>
<p><b>Shaft</b></p> <p>Length = IIII Description (material depending on application)</p>	 <p>TD 528-034</p> <p><b>-SIIII-</b> SS shaft, length according to application</p>						
<p><b>Energy Saving Foils</b></p> <p>Diameter = vv (125 mm to 1900 mm)</p> <p>Description (material depending on application)</p>	 <p>TD 528-001</p> <p><b>-PvvvD3P</b> 3 - bladed propeller, finish: polished Standard: Ra &lt; 0.8 µm</p>	 <p>TD 528-001</p> <p><b>-PvvvD3PE</b> 3 - bladed propeller, finish: polished and electro polished Standard: Ra &lt; 0.8 µm</p>	 <p>TD 528-001a</p> <p><b>-PvvvD3G</b> 3 - bladed propeller, finish: shot peened</p>				
<p><b>Optional</b></p> <p>Description</p>	 <p>TD 528-005</p> <p><b>Welding flange</b> Incl. mounting pin bolts and nuts</p>	 <p>TD 528-006</p> <p><b>Blind flange</b> Incl. O-ring seal</p>	 <p>TD 528-007</p> <p><b>Cover for Motor / gear motor )</b> Stainless steel cover - comes in different shapes according to drive type</p>	<p><b>S</b> <b>Spare part kit</b> Standard spare part kit</p>			



# Efficient Mixing and Agitation

Top mounted agitators, type ALT

## Applications

Application	Typical examples
Maintain Media Homogeneous	Milk storage tanks, cream tanks, mixed product tanks, UHT product storage tanks, etc.
Mixing and Solutions (dissolve)	Fluid and fluid mixing, i.e. drinking yoghurt and fruit mix tanks, flavoured milk mix tanks, syrup mix tanks, etc.
Solid Dispersion	Powder protein + oil mix tanks, micro salt + milk product mix tanks, etc.
Suspension	Fluids with particles, i.e. juice tanks, crystallising tanks etc.
Heat transmission	Circulation of media in tanks with dimple jacket (cooling or heating)
Dairy Fermentation (break coagula + mixing)	Yoghurt tanks, cheese culture tanks, crème fraîche, etc.



## TECHNICAL DATA

### Motor

Motor size and speed as required for duty.  
As standard with IEC motor IP55, other types on request. As standard painted RAL5010.

### Voltage and frequency

As standard for 3x380 to 420V, 50Hz - 3x440V to 480V, 60Hz.  
All motor voltages and frequencies are available.

### Gears

Different gear types available according to configuration.  
As standard filled with normal synthetic or mineral oil, optional: Food approved oil. As standard painted RAL5010.

### ATEX - option

Agitators can be delivered approved for use in an ATEX environment with declaration of conformity according to directive 94/9/EC.

### Ordering

The following information is required to ensure correct sizing and configuration for ordering:

- Tank geometry
- Product properties
- Task of agitator
- Enquiry forms are available

## PHYSICAL DATA

### Materials

Available materials

Steel parts: . . . . . AISI 316L (standard)  
 AISI 304  
 AISI 904L  
 SAF 2205  
 Other materials on request.

Seal rubber parts

(O-rings or bellows): . . . . . EPDM  
 FPM/FEP (only for stationary o-rings)  
 FPM  
 Other materials on request.

Mechanical seal parts: . . . . .

Carbon  
 Carbon (FDA)  
 Silicon carbide

### Material certificate - option

3.1 Material certificates/FDA conformity statement according to 21 CFR177 on steel/elastomer parts in contact with the media

### Dimensions

Standard propeller diameter range:  $\varnothing$ 125 mm to 1900 mm.  
 Specific dimensions on the drive unit and propeller(s) will depend on the actual configuration selected.





**Standard design**

The Alfa Laval range of top mounted propeller agitators is designed to meet almost every customer requirement. Type ALT agitators are characterized by their free hanging shaft without bottom support. Due to their modular build, the agitators can be designed for every kind of application in sanitary industries. The modular construction is designed with the aim to meet both European and American standards and regulations, such as EHEDG, USDA, FDA, 3A etc. Please note that Alfa Laval also offer other agitator solutions:

- Type ALTB, top mounted agitators with bottom steady bearing
- Type ALS, side mounted agitators
- Type ALB, bottom mounted agitators

For more information please see separate Product Data Sheets.

**Advantageous and profitable design**

Each configuration offers a number of advantages, which are shown in the examples below:

Operation features	Due to
Low energy consumption	the wide range of high efficiency propellers and drive units makes it possible to design for low operational costs
Gentle product treatment	the wide range of high efficiency propellers makes it possible to design for low shear operation

Sanitary features	Due to
Easy external cleaning	stainless steel bearing frame design with seal O-rings (for wash down)
Connections inside the tank (risk zones) can be avoided	bearing frame drives with drive shaft and special internal shaft connection without having a flange coupling inside the tank
Good drip off properties	no plane surfaces or grooves on internal parts
Easy cleaning	no interior shadow sides between the blades and smooth surfaces

Maintenance features	Due to
All service (replacement of wearing parts such as shaft seals, bearings etc.) can be done from out side the tank	bearing frame drives with detachable shaft which can be dismantled from outside the tank
Easy dismantling	use of spider type coupling and stainless steel parts (no corrosion)









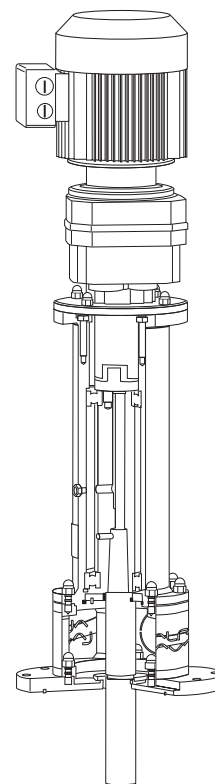

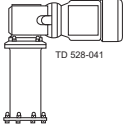
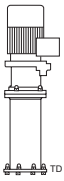
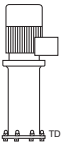
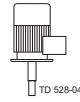
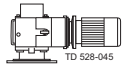
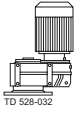
**Configurable design**

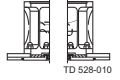
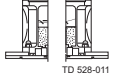
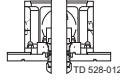
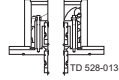
Type ALT agitator design is fully configurable divided in the following elements:

- Drives (drive + shaft support + shaft diameter)
- Seal arrangements (oil trap + shaft seal type)
- Shaft (length)
- Energy Saving Foils (propeller type + surface finish)
- Options

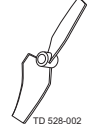
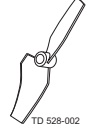
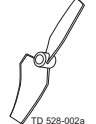
Each element has a broad range of different characteristics which make it possible to size the agitator for all applications and requirements.



Type ALT	Configuration						Top mounted agitators
<p><b>Drives</b></p> <p>Bearing frame size = xx Shaft diameter = yy (not used if xx = yy)</p> <p>Description (power, speed and shaft diameter depending on application)</p>	 <p>TD 528-041</p> <p><b>-ME-GR-Bxx(yy)</b></p> <p>Stainless steel bearing frame and right angle gearbox (for low head room applications)</p>	 <p>TD 528-042</p> <p><b>-ME-GC-Bxx(yy)</b></p> <p>Stainless steel bearing frame and coaxial gearbox</p>	 <p>TD 528-043</p> <p><b>-ME-Bxx(yy)</b></p> <p>Stainless steel bearing frame and direct motor drive</p>	 <p>TD 528-044</p> <p><b>-ME-yy</b></p> <p>Direct motor drive, shaft connected directly to motor</p>	 <p>TD 528-045</p> <p><b>-ME-GR-yy -ME-GW-yy</b></p> <p>Right angle (GR) or worm (GW) gear drive, shaft mounted in hollow shaft of gearbox (for very low head room applications)</p>	 <p>TD 528-032</p> <p><b>-ME-GP-yy</b></p> <p>Parallel shaft gearbox, shaft mounted in hollow shaft of gearbox</p>	
<p><b>Seal arrangements</b></p> <p>Description (lower flange and seal material depending on application)</p>	 <p>TD 528-009</p> <p><b>F-R-</b></p> <p>Seal flange with O-ring seal against tank flange, drain, oil trap (only geared versions) and shaft seal: radial seal for atmospheric tanks</p>	 <p>TD 528-010</p> <p><b>LF-R-</b></p> <p>Lantern (spacer), seal flange with O-ring seal against tank flange, drain, oil trap and shaft seal: radial seal for atmospheric tanks</p>	 <p>TD 528-011</p> <p><b>LF-S-</b></p> <p>Lantern (spacer), seal flange with O-ring seal against tank flange, drain, oil trap and shaft seal: single mechanical dry running seal for high/low pressure applications</p>	 <p>TD 528-012</p> <p><b>LF-D-</b></p> <p>Lantern (spacer), seal flange with O-ring seal against tank flange, drain, oil trap and shaft seal: double mechanical seal for high pressure applications and aseptic use</p>	 <p>TD 528-013</p> <p><b>LF-DT-</b></p> <p>Lantern (spacer), seal flange with O-ring seal against tank flange, drain, oil trap and shaft seal: double mechanical seal (tandem) for low pressure applications</p>		
<p><b>Shaft</b></p> <p>Length = IIII Description (material depending on application)</p>	 <p>TD 528-009</p> <p><b>-SIII-</b></p> <p>SS shaft, length according to application</p>						
<p><b>Energy Saving Foils</b></p> <p>Number =n Diameter = vv (125 mm to 1900 mm)</p> <p>Description (material depending on application)</p>	 <p>TD 528-001</p> <p><b>-nPvvD3P</b></p> <p>3 - bladed propeller, finish: polished Standard: Ra &lt; 0.8 µm</p>	 <p>TD 528-001</p> <p><b>-nPvvD3PE</b></p> <p>3 - bladed propeller, finish: polished and electro polished Standard: Ra &lt; 0.8 µm</p>	 <p>TD 528-001a</p> <p><b>-nPvvD3G</b></p> <p>3 - bladed propeller, finish: shot peened</p>	 <p>TD 528-002</p> <p><b>-nPvvD2P</b></p> <p>2 - bladed propeller, finish: polished Standard: Ra &lt; 0.8 µm</p>	 <p>TD 528-002</p> <p><b>-nPvvD2PE</b></p> <p>2 - bladed propeller, finish: polished and electro polished Standard: Ra &lt; 0.8 µm</p>	 <p>TD 528-002a</p> <p><b>-nPvvD2G</b></p> <p>2 - bladed propeller, finish: glass shot peened</p>	
<p><b>Optional</b></p> <p>Description</p>	 <p>TD 528-005</p> <p><b>Welding flange</b></p> <p>Incl. mounting pin nuts and bolts</p>	 <p>TD 528-006</p> <p><b>Blind flange</b></p> <p>Incl. seal O-ring</p>	 <p>TD 528-007</p> <p><b>Cover for Motor / gear motor</b></p> <p>Stainless steel cover - comes in different shapes according to drive type</p>	<p><b>S</b></p> <p><b>Spare part kit</b></p> <p>Standard spare part kit</p>			



# Efficient Mixing and Agitation

## Top mounted agitators, type ALTB

### Applications

Application	Typical examples
Maintain media homogeneous	Milk storage tanks, cream tanks, mixed product tanks, UHT product storage tanks, etc.
Mixing and Solutions (dissolves)	Fluid and fluid mixing, i.e. drinking yoghurt and fruit mix tanks, flavoured milk mix tanks, syrup mix tanks, etc.
Solid Dispersion	Powder protein + oil mix tanks, micro salt + milk product mix tanks, etc.
Suspension	Fluids with particles, i.e. juice tanks, crystallising tanks etc.
Heat transmission	Circulation of media in tanks with dimple jacket (cooling or heating)
Dairy Fermentation (break coagula + mixing)	Yoghurt tanks, cheese culture tanks, crème fraîche, etc.



### TECHNICAL DATA

#### Motor

Motor size and speed as required for duty. As standard with IEC motor IP55, other types on request. As standard painted RAL5010.

#### Voltage and frequency

As standard for 3x380 to 420V, 50Hz - 3x440V to 480V, 60Hz. All motor voltages and frequencies are available.

#### Gears

Different gear types available according to configuration.

As standard filled with normal synthetic or mineral oil, optional: Food approved oil. As standard painted RAL5010.

#### ATEX - option

Agitators can be delivered approved for use in an ATEX environment with declaration of conformity according to directive 94/9/EC.

#### Ordering

The following information is required to ensure correct sizing and configuration for ordering:

- Tank geometry
- Product properties
- Task of agitator
- Enquiry forms are available

### PHYSICAL DESIGN

#### Materials

Available materials:

Steel parts: . . . . . AISI 316L (standard)  
 AISI 304  
 AISI 904L  
 SAF 2205  
 Other materials on request.

Seal rubber parts

(O-rings or bellows): . . . . . EPDM  
 FPM/FEP (only for stationary o-rings)  
 FPM  
 Other materials on request.

Mechanical seal parts: . . . . .

Carbon  
 Carbon (FDA)  
 Silicon carbide

Wear bushings

(bottom steady bearing): . . . . . PTFE (BS1P/BS1G)  
 PVDF (BS2P)

#### Material certificate - option

3.1 Material certificates/FDA conformity statement according to 21 CFR177 on steel/elastomer parts in contact with media

#### Dimensions

Standard propeller diameter range:  $\varnothing$ 125 mm to 1900 mm. Specific dimensions on the drive unit and propeller(s) will depend on the actual configuration selected.



**Standard design**

The Alfa Laval range of top mounted propeller agitators with bottom steady bearing is designed to meet almost every customer requirement. Type ALTB agitators are characterised by having a shaft support inside the tank called a bottom steady bearing. Standard type ALTB agitators are less costly than agitators without internal shaft support. Due to their modular build, the agitators can be designed to suit every kind of application within sanitary industry. The modular construction is designed with the aim to meet both European and American standards and regulations, such as EHEDG, USDA, FDA, 3A etc.

Please note that Alfa Laval also offer other agitator solutions:

- Type ALT, top mounted agitators
- Type ALS, side mounted agitators
- Type ALB, bottom mounted agitators

For more information please see separate Product Data Sheets.

**Configurable design**

Type ALTB agitator design is fully configurable divided in the following elements:

- Drives (drive + shaft support + shaft diameter)
- Seal arrangements (oil trap + shaft seal type)
- Shaft (length)
- Energy Saving Foils (propeller type + surface finish)
- Bottom steady bearings (type + surface finish)
- Options

Each element has a broad range of different characteristics which make it possible to size the agitator for all applications and requirements. Type ALTB configuration, please see next page.

**Advantageous and profitable design**

Each configuration offers a number of advantages, which are shown in the examples below:

Operation features	Due to
Low energy consumption	the wide range of high efficiency propellers and drive units makes it possible to design for low operational costs
Gentle product treatment	the wide range of high efficiency propellers makes it possible to design for low shear operation

Sanitary features	Due to
Connections inside the tank (risk zones) can be avoided	propellers can be welded onto the shaft
Good drip off properties	no plane surfaces or grooves on internal parts
Easy cleaning	no interior shadow sides between the blades and smooth surfaces











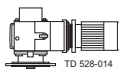
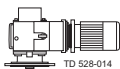
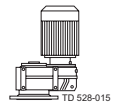



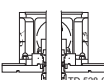
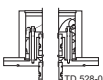

Maintenance features	Due to
Easy bottom bearing replacement	wear bushings can be replaced without dismantling the agitator drive

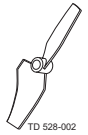

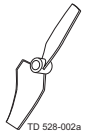
BS1P



BS2P

Type ALTB	Configuration						Top mounted agitators with bottom steady bearing					
<p><b>Drives</b></p> <p>Shaft diameter = yy Description (power, speed and shaft diameter depending on application)</p>	 <p>TD 528-014</p> <p><b>-ME-GR-yy</b></p> <p>Right angle gear drive, shaft mounted in hollow shaft of gearbox (for very low head room applications)</p>	 <p>TD 528-014</p> <p><b>-ME-GW-yy</b></p> <p>Worm gear drive, shaft mounted in hollow shaft of gearbox (for very low head room applications)</p>	 <p>TD 528-015</p> <p><b>-ME-GP-yy</b></p> <p>Parallel shaft gearbox, shaft mounted in hollow shaft of gearbox</p>									
<p><b>Seal arrangements</b></p> <p>Description (lower flange and seal material depending on application)</p>	 <p>TD 528-009</p> <p><b>F-R-</b></p> <p>Seal flange with O-ring seal against tank flange, drain, oil trap and shaft seal: radial seal for atmospheric tanks</p>	 <p>TD 528-010</p> <p><b>LF-R-</b></p> <p>Lantern (spacer), seal flange with O-ring seal against tank flange, drain, oil trap and shaft seal: radial seal for atmospheric tanks</p>	 <p>TD 528-011</p> <p><b>LF-S-</b></p> <p>Lantern (spacer), seal flange with O-ring seal against tank flange, drain, oil trap and shaft seal: single mechanical dry running seal for high/low pressure applications</p>	 <p>TD 528-012</p> <p><b>LF-D-</b></p> <p>Lantern (spacer), seal flange with O-ring seal against tank flange, drain, oil trap and shaft seal: double mechanical seal for high pressure applications and aseptic use</p>	 <p>TD 528-013</p> <p><b>LF-DT-</b></p> <p>Lantern (spacer), seal flange with O-ring seal against tank flange, drain, oil trap and shaft seal: double mechanical seal (tandem) for low pressure applications</p>							
<p><b>Shaft</b></p> <p>Length = IIII Description (material depending on application)</p>	 <p><b>-SIII-</b></p> <p>SS shaft, length according to application</p>											
<p><b>Energy Saving Foils</b></p> <p>Number =n Diameter =vvv (125 mm to 1900 mm)</p> <p>Description (material depending on application)</p>	 <p>TD 528-001</p> <p><b>-nPvvvD3P</b></p> <p>3 - bladed propeller, finish: polished Standard: Ra &lt; 0.8 µm</p>	 <p>TD 528-001</p> <p><b>-nPvvvD3PE</b></p> <p>3 - bladed propeller, finish: polished and electro polished Standard: Ra &lt; 0.8 µm</p>	 <p>TD 528-001a</p> <p><b>-nPvvvD3G</b></p> <p>3 - bladed propeller, finish: shot peened</p>	 <p>TD 528-002</p> <p><b>-nPvvvD2P</b></p> <p>2 - bladed propeller, finish: polished Standard: Ra &lt; 0.8 µm</p>	 <p>TD 528-002</p> <p><b>-nPvvvD2PE</b></p> <p>2 - bladed propeller, finish: polished and electro polished Standard: Ra &lt; 0.8 µm</p>	 <p>TD 528-002a</p> <p><b>-nPvvvD2G</b></p> <p>2 - bladed propeller, finish: glass shot peened</p>						
<p><b>Bottom steady bearing</b></p> <p>Description (material depending on application)</p>	 <p>TD 528-003</p> <p><b>-BS1P</b></p> <p>Bottom steady bearing with PTFE bushing finish: polished Standard: Ra &lt; 0.8 µm</p>	 <p>TD 528-003a</p> <p><b>-BS1G</b></p> <p>Bottom steady bearing with PTFE bushing finish: shot peened</p>	 <p>TD 528-004</p> <p><b>-BS2P</b></p> <p>Sanitary bottom steady bearing with PVDF bushings finish: polished Standard: Ra &lt; 0.8 µm</p>									
<p><b>Optional</b></p> <p>Description</p>	 <p>TD 528-005</p> <p><b>Welding flange</b></p> <p>Incl. mounting pin nuts and bolts</p>	 <p>TD 528-006</p> <p><b>Blind flange</b></p> <p>Incl. seal O-ring</p>	 <p>TD 528-007</p> <p><b>Cover for motor / gear motor</b></p> <p>Stainless steel cover - comes in different shapes according to drive type</p>	<p><b>S</b></p> <p><b>Spare part kit</b></p> <p>Standard spare part kit</p>								



# Efficient Mixing and Agitation

## Bottom mounted agitators Type ALB

### Applications

Application	Typical examples
Maintain media homogeneous	Milk storage tanks, mixed product tanks, UHT storage tanks etc.
Mixing and Solutions (dissolves)	Fluid and fluid mixing, i.e. drinking yoghurt and fruit mix tanks, flavoured milk mix tanks, syrup mix tanks, etc.
Solid Dispersion	Powder + fluid mix tanks, etc.
Suspension	Fluids with particles, i.e. juice tanks
Heat transmission	Circulation of media in tanks with dimple jacket (cooling or heating)



### TECHNICAL DATA

#### Motor

Motor size and speed as required for duty.  
As standard with IEC motor IP55, other types on request.  
As standard painted RAL5010.

#### Voltage and frequency

As standard for 3x380 to 420V, 50Hz - 3x440V to 480V, 60Hz.  
All motor voltages and frequencies are available.

#### Gears

Different gear types available according to configuration.  
As standard filled with normal synthetic or mineral oil, optional: Food approved oil. As standard painted RAL5010.

#### ATEX - option

Agitators can be delivered approved for use in an ATEX environment with declaration of conformity according to directive 94/9/EC.

#### Ordering

The following information is required to ensure correct sizing and configuration for ordering:

- Tank geometry
- Product properties
- Task of agitator
- Enquiry forms are available

### PHYSICAL DATA

#### Materials

List the range of materials available for wetted parts:

Steel parts: . . . . . AISI 316L (standard)  
 . . . . . AISI 304  
 . . . . . AISI 904L  
 . . . . . SAF 2205  
 . . . . . Other materials on request.

Seal rubber parts  
 (o-rings or bellows): . . . . . EPDM  
 . . . . . FPM/FEP (only for stationary o-rings)  
 . . . . . FPM  
 . . . . . Other materials on request.

Specific selection of materials will depend on the actual configuration selected.

#### Material certificate - option

3.1 Material certificates/FDA conformity statement according to 21 CFR177 on steel/elastomer parts in contact with media

#### Dimensions

Standard propeller diameter range:  $\varnothing$ 125 mm to 1900 mm.  
 Specific dimensions on the drive unit and propeller(s) will depend on the actual configuration selected.



**Standard design**

The Alfa Laval range of bottom mounted propeller agitators is designed to meet almost every customer requirement. Due to their modular build the agitators can be designed for every type of application with the sanitary industry. The modular construction is designed with the aim to meet both European and American standards and regulations, such as EHEDG, USDA, FDA, 3A etc.

**Configurable design**

Type ALB agitator design is fully configurable divided in the following elements:

- Drives (drive + shaft support + shaft diameter)
- Seal arrangements (oil trap + shaft seal type)
- Shaft (length)
- Energy Saving Foils (propeller type + surface finish)
- Options

Each element has a broad range of different characteristics which makes it possible to size the agitator for all applications and requirements.

**Advantageous and profitable design**









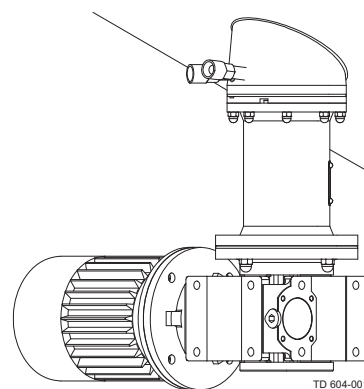
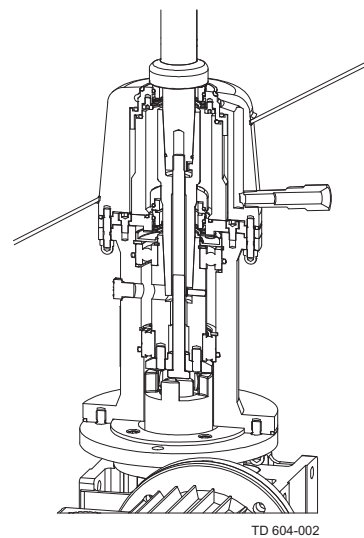
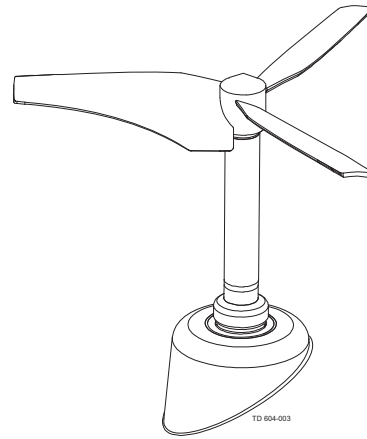

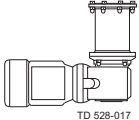
Each configuration offers a number of advantages, which are shown in the examples below:

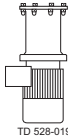
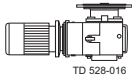
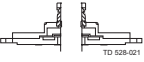
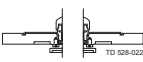
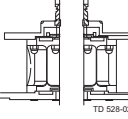
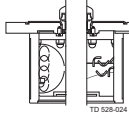
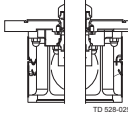
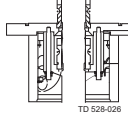
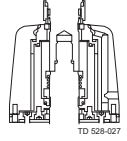
Operation features	Due to
Low energy consumption	the wide range of high efficiency propellers and drive units makes it possible to design for low operational costs
Gentle product treatment	the wide range of high efficiency propellers makes it possible to design for low shear operation

Sanitary features	Due to
Easy external cleaning	stainless steel bearing frame design with seal O-rings (for washing)
Connections inside the tank (risk zones) can be minimised	bearing frame drives with drive shaft and special internal shaft connection without having a flange coupling inside the tank
All seals both stationary and rotating seals are sterilised during running	the unique cone shaped seal arrangement with flushed sterile seal system
Good drip off properties	no plane surfaces or grooves on internal parts
Easy cleaning	no interior shadow sides between the blades and smooth surfaces

Maintenance features	Due to
All service (replacement of wearing parts such as shaft seals, bearings etc.) can be done from outside the tank	bearing frame drives with detachable shaft which can be dismantled from outside the tank
Easy dismantling	use of spider type coupling and stainless steel parts



Type ALB	Configuration							Bottom mounted agitators
<b>Drives</b> Bearing frame size = xx Shaft diameter = yy (not used if xx = yy)  Description (power, speed and shaft diameter depending on application)	 TD 528-017  <b>-ME-GR-Bxx(yy)</b> Right angle gearbox, shaft mounted in hollow shaft of gearbox	 TD 528-018  <b>-ME-GC-Bxx(yy)</b> Stainless steel bearing frame and coaxial gearbox	 TD 528-019  <b>-ME-Bxx(yy)</b> Stainless steel bearing frame and direct motor drive	 TD 528-016  <b>-ME-GR-yy</b> Right angle gearbox, shaft mounted in hollow shaft of gearbox				
<b>Seal arrangements</b>  Description (lower flange and seal material depending on application)	 TD 528-021  <b>F-S1-</b> Seal flange with O-ring seal against tank flange, drain, fluid trap and shaft seal: single mechanical bellow seal	 TD 528-022  <b>F-S2-</b> Seal flange with O-ring seal against tank flange, drain, fluid trap and shaft seal: single mechanical non-bellow seal	 TD 528-023  <b>LF-S1-</b> Lantern (spacer), seal flange with O-ring seal against tank flange, drain, fluid trap and shaft seal: single mechanical bellow seal	 TD 528-024  <b>LF-S2-</b> Lantern (spacer), seal flange with O-ring seal against tank flange, drain, fluid trap and shaft seal: single mechanical non-bellow seal	 TD 528-025  <b>LF-D-</b> Lantern (spacer), seal flange with O-ring seal against tank flange, drain, fluid trap and shaft seal: double mechanical seal for high pressure applications and aseptic use	 TD 528-026  <b>LF-DT-</b> Lantern (spacer), seal flange with O-ring seal against tank flange, drain, fluid trap and shaft seal: double mechanical seal (tandem) for low pressure applications	 TD 528-027  <b>C-D-</b> Cone shaped welding flange, flushed O-ring seal between welding flange and agitator seal house, drain, fluid trap and shaft seal: double mechanical sterile seal for high pressure applications and aseptic use	
<b>Shaft</b> Length = llll  Description (material depending on application)	 TD 528-020  <b>-SIII-</b> SS shaft, length according to application							
<b>Energy Saving Foils</b> Diameter = vvv (125 mm to 1900 mm)  Description (material depending on application)	 TD 528-011  <b>-PvvU3P</b> 3 - bladed propeller, finish: polished Standard: Ra < 0.8 µm	 TD 528-011  <b>-PvvU3PE</b> 3 - bladed propeller, finish: polished and electro polished Standard: Ra < 0.8 µm	 TD 528-011  <b>-PvvU3G</b> 3 - bladed propeller, finish: shot peened					
<b>Optional</b>  Description	 TD 528-005  <b>Welding flange</b> Incl. mounting pin nuts and bolts	 TD 528-006  <b>Blind flange</b> Incl. seal O-ring	 TD 528-007  <b>Cover for Motor / gear motor</b> Stainless steel cover - comes in different shapes according to drive type	<b>S</b> <b>Spare part kit</b> Standard spare part kit				



# Superior mixing – Liquid, Gas and Powder

## IM 10 Rotary Jet Mixer

The patented IM 10 Rotary Jet Mixer (RJM) does not only mix fast, efficient and uniform but creates also the necessary process flexibility that makes it easy to switch to new product formulations with diverse viscosities, densities and volumes. Besides classic liquid to liquid mixing the RJM is excellent for gas and powder dispersion plus a superb tank cleaning machine.

**Applications**

Process and storage vessels between 1-10 m<sup>3</sup> used in a wide range of industries such as: beer & beverage, food & ingredients, home & personal care, health care, biotech and chemical industry etc.

**Operation**

Secure that the mixer is positioned in the correct level and submerged into the liquid before round pumping or when adding any additional products from any up-stream pipe works.



**TECHNICAL DATA**

Lubricant: . . . . . Self-lubricating with the mixing/cleaning fluid  
 Standard thread: . . . . . 1" BSP or NPT, female, Top cone 1" BSP with sanitary seal  
 Min. tank opening: . . . . . See dimension drawings

**Pressure**

Working pressure: . . . . . 2-8 bar  
 Recommended pressure during mixing: . . . . . 2-6 bar  
 Recommended pressure during CIP: . . . . . 4-8 bar

**PHYSICAL DATA**

**Materials**

Materials: . . . . . AISI 316L, AISI 316, SAF 2205 (UNS 31803), EPDM, PEEK, PVDF, PFA, Ceramics

**Weight:** . . . . . 5.1 kg

**Temperature**

Max. working temperature: . . . . . 95°C  
 Max. ambient temperature: . . . . . 140°C

**Certificates**

2.1 material certificate ATEX.

**Benefits**

Using the IM 10 Rotary Jet Mixer makes it possible, at a modest investment, to perform fast and efficient mixing in a sanitary system. In traditional systems, using propeller mixers, a rotating shaft penetrates the tank wall, and a mechanical seal and a gear box are installed. With the Rotary Jet Mixer technology the shaft, seal and gearbox are eliminated, and a more sanitary design is obtained. With the Rotary Jet Mixing technology good mixing is achieved without the use of baffles. The Rotary Jet Mixer can also be used for gas dispersion. The IM 10 can furthermore be used for efficient CIP when the tank is empty, saving liquid, chemicals and energy compared to a fixed spray ball CIP system.



**Flow rate**

Relationship between inlet pressure and flow rate for liquids with waterlike properties for the IM 10 Rotary Jet Mixer.

**Volumetric flow rate [m<sup>3</sup>/h]**

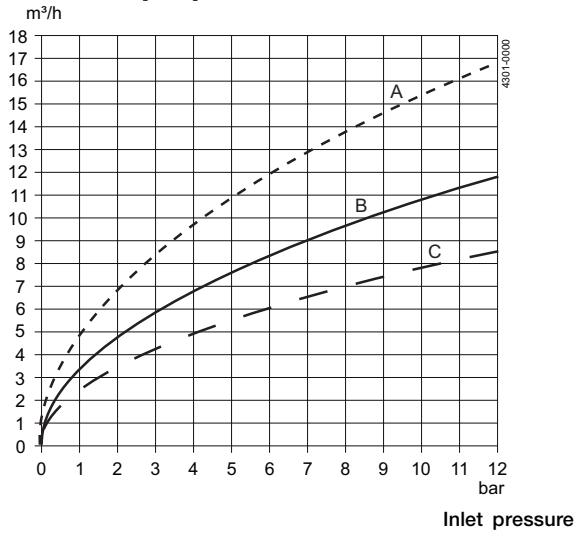

- Nozzles  
 A) d = 5.5 mm  
 B) d = 4.6 mm  
 C) d = 3.9 mm

**Reach of jet**

Reach of jet for the IM 10 during cleaning, and indicative reach of jet for mixing of liquids with water-like properties.

**Reach of jet [m]**

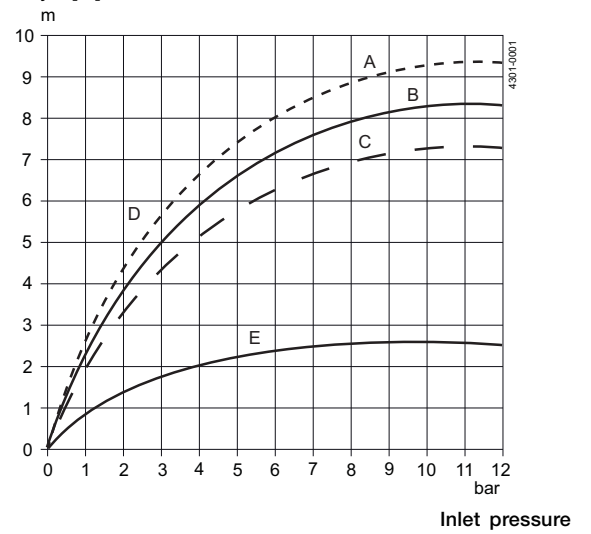

- Nozzles  
 A) d = 5.5 mm  
 B) d = 4.6 mm  
 C) d = 3.9 mm  
 D) Cleaning  
 E) Mixing

**Dimensions (mm)**

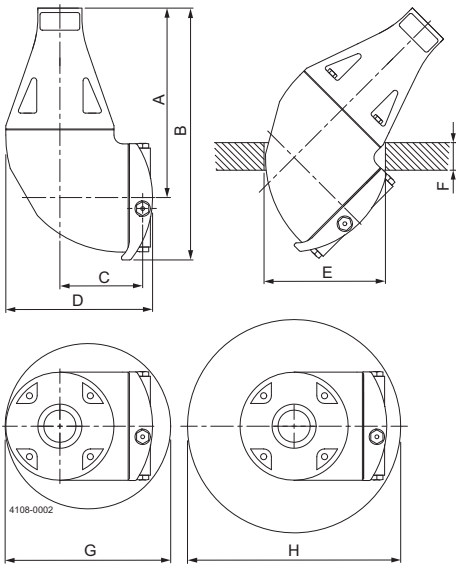

**The Rotary Jet Mixing technology**

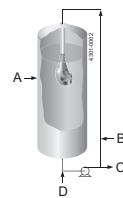

- A = Rotary Jet Mixer  
 B = Gas  
 C = Product  
 D = Liquid feed

**Traditional Mixing technology**

**Round pumping Propeller mixing**

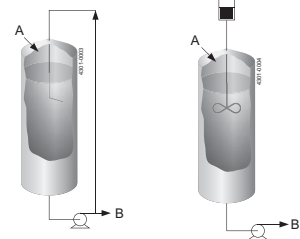

- A = Liquid feed  
 B = Product

A	B	C	D	E	F	G	H
173	230	75	133	ø110	Max. 25	ø150	ø200

# Superior Mixing – Liquid, Gas and Powder

## IM 15 Rotary Jet Mixer

The patented IM 15 Rotary Jet Mixer (RJM) does not only mix fast, efficient and uniform but creates also the necessary process flexibility that makes it easy to switch to new product formulations with diverse viscosities, densities and volumes. Besides classic liquid to liquid mixing the RJM is excellent for gas and powder dispersion plus a superb tank cleaning machine.

**Applications**

Process and storage vessels between 2-100 m<sup>3</sup> used in a wide range of industries such as: beer & beverage, food & ingredients, home & personal care, health care, biotech and chemical industry etc.

**Operation**

Secure that the mixer is positioned in the correct level and submerged into the liquid before round pumping or when adding any additional products from any up-stream pipe works.



**TECHNICAL DATA**

Lubricant: . . . . . Self-lubricating with the mixing/cleaning fluid  
 Connection: . . . . . Standard thread 1.5" BSP or NPT, female  
 Min. tank opening: . . . . . See dimension drawings

**Pressure**

Working pressure: . . . . . 2-12 bar  
 Recommended pressure during mixing: . . . . . 2-6 bar  
 Recommended pressure during CIP: . . . . . 5-6.5 bar

**PHYSICAL DATA**

**Materials**

Materials: . . . . . AISI 316L, AISI 316, SAF 2205, PTFE, PEEK, Tefzel, Ceramics

**Weight:**

. . . . . 6.1 kg

**Temperature**

Max. working temperature: . . . . . 95°C  
 Max. ambient temperature: . . . . . 140°C

**Benefits**

Using the IM 15 Rotary Jet Mixer makes it possible, at a modest investment, to perform fast and efficient mixing in a sanitary system. In traditional systems, using propeller mixers, a rotating shaft penetrates the tank wall, and a mechanical seal and a gear box are installed. With the Rotary Jet Mixing technology the shaft, seal and gearbox are eliminated, and a more sanitary design is obtained. With the Rotary Jet Mixing technology good mixing is achieved without the use of baffles. The Rotary Jet Mixer can also be used for gas dispersion and for dispersion and dissolving of powder. The IM 15 can furthermore be used for efficient CIP when the tank is empty, saving liquid, chemicals and energy compared to a fixed spray ball CIP system



**Flow rate**

Relationship between inlet pressure and flow rate for liquids with waterlike properties for the IM 15 Rotary Jet Mixer.

**Volumetric flow rate [m<sup>3</sup>/h]**

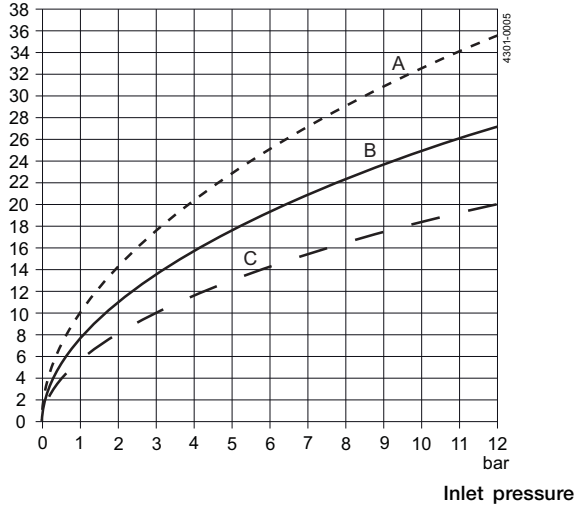

- Nozzles  
 A) d = 8 mm  
 B) d = 7 mm  
 C) d = 6 mm

**Reach of jet**

Reach of jet for the IM 15 during cleaning, and indicative reach of jet for mixing of liquids with water-like properties.

**Reach of jet [m]**

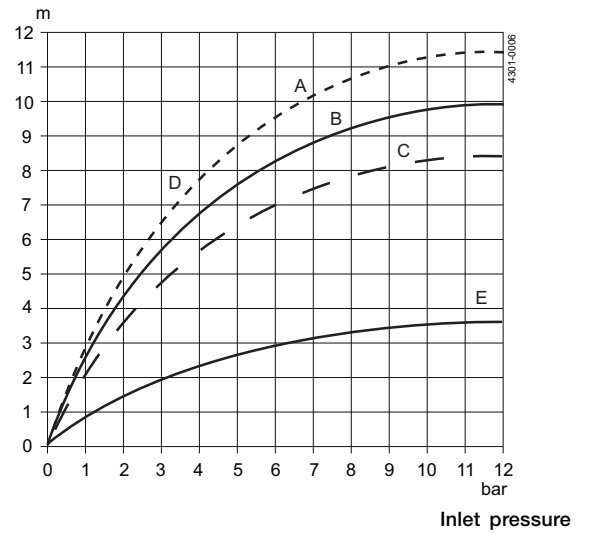

- Nozzles  
 A) d = 8 mm  
 B) d = 7 mm  
 C) d = 6 mm  
 D) Cleaning  
 E) Mixing

**Dimensions (mm)**

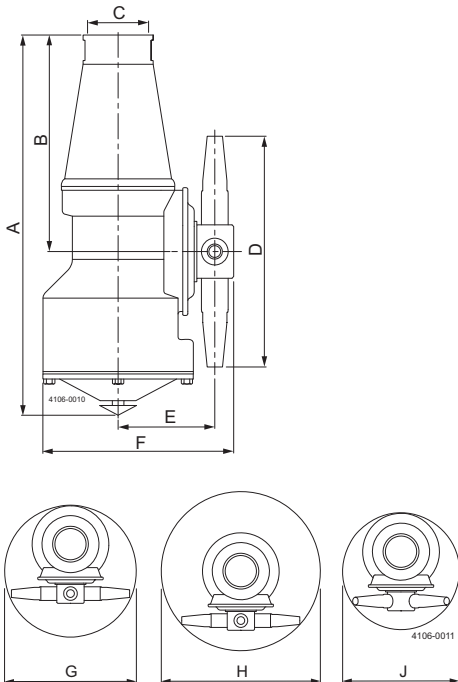

**The Rotary Jet Mixing technology**

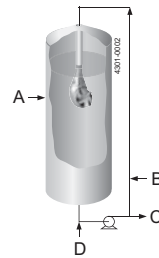

- A = Rotary Jet Mixer  
 B = Gas  
 C = Product  
 D = Liquid feed

**Traditional Mixing technology**

**Round pumping Propeller mixing**

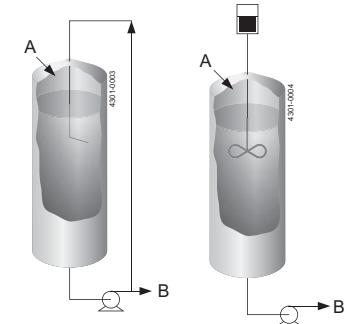

- A = Liquid feed  
 B = Product

A	B	C	D	E	F	G	H	J
297	170	50	204	78	152	ø216	ø264	ø180

# Superior mixing – Liquid, Gas and Powder

## IM 20 Rotary Jet Mixer

The patented IM 20 Rotary Jet Mixer (RJM) does not only mix fast, efficient and uniform but creates also the necessary process flexibility that makes it easy to switch to new product formulations with diverse viscosities, densities and volumes. Besides classic liquid to liquid mixing the RJM is excellent for gas and powder dispersion plus a superb tank cleaning machine.

**Applications**

Process and storage vessels between 5-200 m<sup>3</sup> used in a wide range of industries such as: beer & beverage, food & ingredients, home & personal care, health care, biotech and chemical industry etc.

**Operation**

Secure that the mixer is positioned in the correct level and submerged into the liquid before round pumping or when adding any additional products from any up-stream pipe works.



**TECHNICAL DATA**

Lubricant: . . . . . Self-lubricating with the mixing/cleaning fluid  
 Connection: . . . . . Standard thread 2" BSP or NPT, female  
 Min. tank opening: . . . . . See dimension drawings

**Pressure**

Working pressure: . . . . . 2-12 bar  
 Recommended pressure during mixing: . . . . . 2-6 bar  
 Recommended pressure during CIP: . . . . . 5-6.5 bar

**PHYSICAL DATA**

**Materials**

Materials: . . . . . AISI 316L, AISI 316, SAF 2205, PEEK, PVDF, Tefzel, Ceramics

**Weight:** . . . . . 12.2 kg

**Temperature**

Max. working temperature: . . . . . 95°C  
 Max. ambient temperature: . . . . . 140°C

**Benefits**

Using the IM 20 Rotary Jet Mixer makes it possible, at a modest investment, to perform fast and efficient mixing in a sanitary system. In traditional systems, using propeller mixers, a rotating shaft penetrates the tank wall, and a mechanical seal and a gear box are installed. With the Rotary Jet Mixer technology the shaft, seal and gearbox are eliminated, and a more sanitary design is obtained. With the Rotary Jet Mixing technology good mixing is achieved without the use of baffles. The Rotary Jet Mixer can also be used for gas dispersion and for dispersion and dissolving of powder. The IM 20 can furthermore be used for efficient CIP when the tank is empty, saving liquid, chemicals and energy compared to a fixed spray ball CIP system.



**Flow rate**

Relationship between inlet pressure and flow rate for liquids with waterlike properties for the IM 20 Rotary Jet Mixer.

**Volumetric flow rate [m<sup>3</sup>/h]**

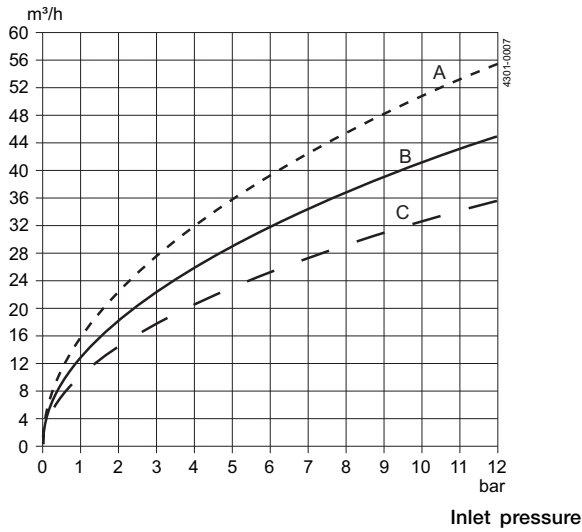

- Nozzles
- A) d = 10 mm
  - B) d = 9 mm
  - C) d = 8 mm

**Reach of jet**

Reach of jet for the IM 20 during cleaning, and indicative reach of jet for mixing of liquids with water-like properties.

**Reach of jet [m]**

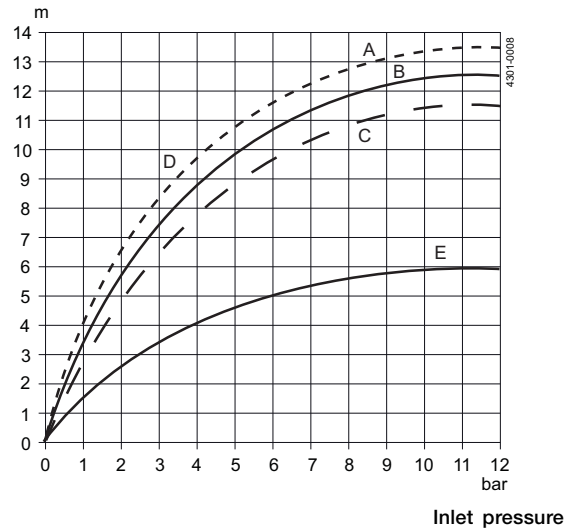

- Nozzles
- A) d = 10 mm
  - B) d = 9 mm
  - C) d = 8 mm
  - D) Cleaning
  - E) Mixing

**Dimensions (mm)**

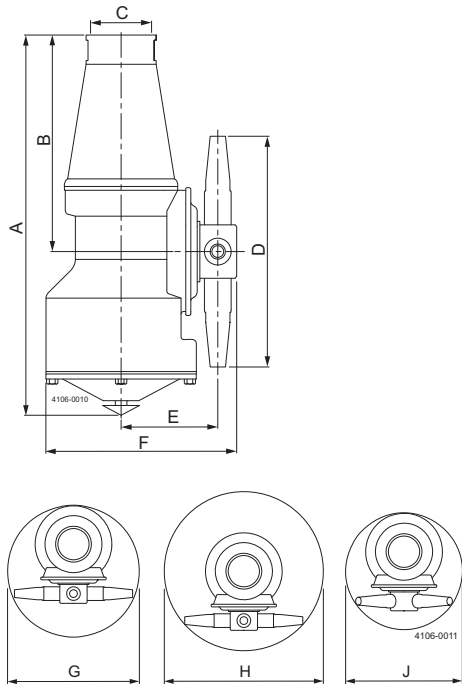

**The Rotary Jet Mixing technology**

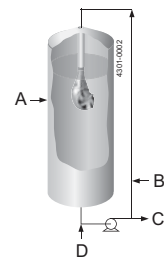

- A = Rotary Jet Mixer
- B = Gas
- C = Product
- D = Liquid feed

**Traditional Mixing technology**

**Round pumping Propeller mixing**

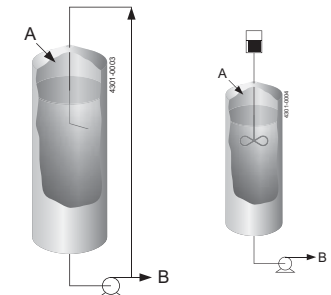

- A = Liquid feed
- B = Product

A	B	C	D	E	F	G	H	J
356	220	65	268	98	195	ø280	ø343	ø232

# Superior Mixing – Liquid, Gas and Powder

## IM 25 Rotary Jet Mixer

The patented IM 25 Rotary Jet Mixer (RJM) does not only mix fast, efficient and uniform but creates also the necessary process flexibility that makes it easy to switch to new product formulations with diverse viscosities, densities and volumes. Besides classic liquid to liquid mixing the RJM is excellent for gas and powder dispersion plus a superb tank cleaning machine.

**Applications**

Process and storage vessels between 10-1000 m<sup>3</sup> used in a wide range of industries such as: beer & beverage, food & ingredients, home & personal care, health care, biotech and chemical industry etc.

**Operation**

Secure that the mixer is positioned in the correct level and submerged into the liquid before round pumping or when adding any additional products from any up-stream pipe works.



**TECHNICAL DATA**

Lubricant: . . . . . Self-lubricating with the mixing/cleaning fluid  
 Connection: . . . . . Standard thread 2.5" BSP, female  
 Min. tank opening: . . . . . See dimension drawings

**Pressure**

Working pressure: . . . . . 2-12 bar  
 Recommended pressure during mixing: . . . . . 4-8 bar  
 Recommended pressure during CIP: . . . . . 5-10 bar

**PHYSICAL DATA**

**Materials**

Materials: . . . . . AISI 316L, AISI 316, SAF 2205, PEEK, PVDF, Carbon, Tefzel, Ceramics

**Weight:** . . . . . 13.2 kg

**Temperature**

Max. working temperature: . . . . . 95°C  
 Max. ambient temperature: . . . . . 140°C

**Benefits**

Using the IM 25 Rotary Jet Mixer makes it possible, at a modest investment, to perform fast and efficient mixing in a sanitary system. In traditional systems, using propeller mixers, a rotating shaft penetrates the tank wall and a mechanical seal and a gear box are installed. With the Rotary Jet Mixing technology the shaft, seal and gearbox are eliminated, and a more sanitary design is obtained. With the Rotary Jet Mixing technology good mixing is achieved without the use of baffles. The Rotary Jet Mixing technology can also be used for gas dispersion and for dispersion and dissolving of powder. The IM 25 can furthermore be used for efficient CIP when the tank is empty, saving liquid, chemicals and energy compared to a fixed spray ball CIP system.



**Flow rate**

Relationship between inlet pressure and flow rate for liquids with waterlike properties for the IM 25 Rotary Jet Mixer.

**Volumetric flow rate [m<sup>3</sup>/h]**

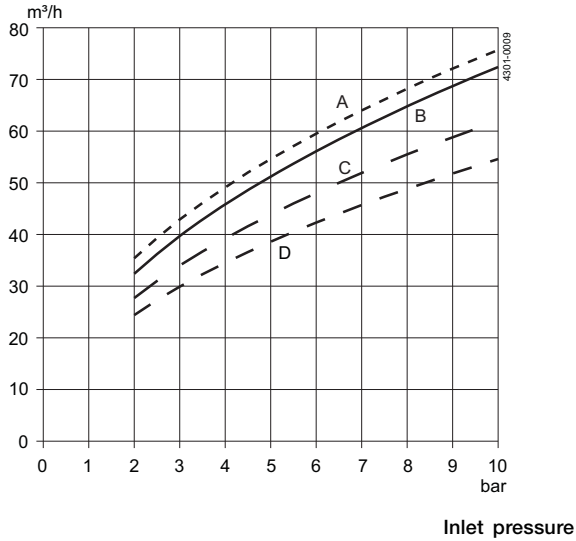

- Nozzles
- A) 2 x  $\varnothing$ 21 mm
  - B) 2 x  $\varnothing$ 19 mm
  - C) 2 x  $\varnothing$ 17 mm
  - D) 2 x  $\varnothing$ 15 mm

**Reach of jet**

Reach of jet for the IM 25 during cleaning, and indicative reach of jet for mixing of liquids with water-like properties.

**Reach of jet [m]**

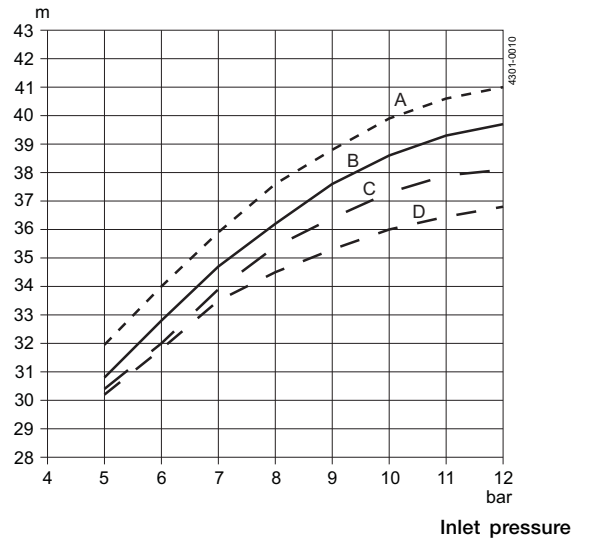

- Nozzles
- A) 2 x  $\varnothing$ 21 mm
  - B) 2 x  $\varnothing$ 19 mm
  - C) 2 x  $\varnothing$ 17 mm
  - D) 2 x  $\varnothing$ 15 mm

**Dimensions (mm)**

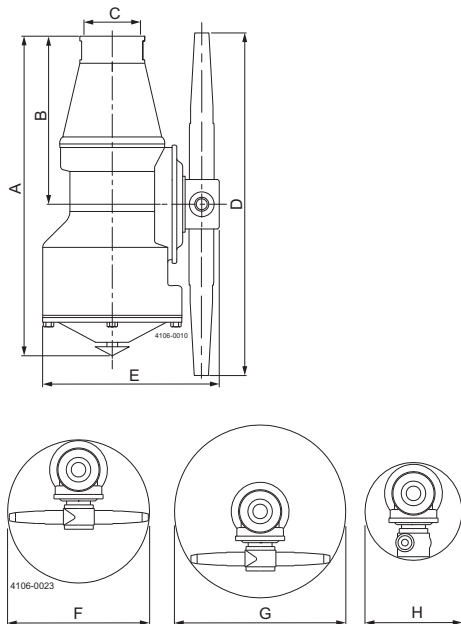

A = 2.5" BSP

A	B	C	D	E	F	G	H
286	155	80	337	220	$\varnothing$ 343	$\varnothing$ 424	$\varnothing$ 223

**The Rotary Jet Mixing technology**

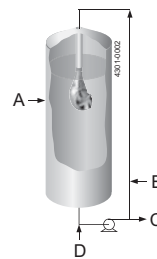

- A = Rotary Jet Mixer
- B = Gas
- C = Product
- D = Liquid feed

**Traditional Mixing technology**

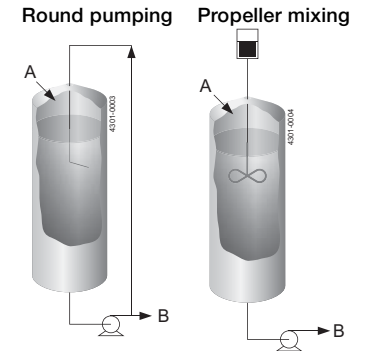

- A = Liquid feed
- B = Product



**Please notice before ordering**

- Standard configuration according to PD sheet.
- Special item number for USP class VI for female silicon carbide bearing
- To ensure easy and problem free operation please always order these three items together: Mixer unit, weld plate and pre-programmed frequency inverter
- If in doubt please contact your Alfa Laval technical support

Item No Ra<0.5	RCPL [EUR]	Item No, Ra<0.5 Electropolished	RCPL [EUR]	Description	Impeller diameter [mm] [inch]		
							<b>Mixer without weldplate</b>
9614063801		9614063805		MM338-4	101.6	4	
9614063802		9614063806		MM338-6	152.4	6	
9614063901		9614063907		MM434-8	203.2	8	
9614063902		9614063908		MM434-10	254.0	10	
9614063903		9614063909		MM434-12	304.8	12	

Item No. Ra<0.5	RCPL [EUR]	Description	Weld plate dimensions			
			øD [mm / inch]	T [mm / inch]	t [mm / inch]	
<b>Weld plate. Required in order for the mixer to work</b>						
9634086405		Weld plate for MM338	90 / 3.5	5 / 0.2	1 / 0.04	
9634086404		Weld plate for MM434	149 / 5.9	6 / 0.2	1 / 0.04	

Item No.	RCPL [EUR]	Description	
			<b>Frequency inverters</b>
9634086478		Lenze M1105SE frequency inverter for 0.37 kW (0.5 HP) drive in stainless steel cabinet (IP66)	
9634086479		Lenze M1115SE frequency inverter for 1.1 kW (1.5 HP) drive in stainless steel cabinet (IP66)	

# Tools and spare parts for Alfa Laval MM UltraPure, Magnetic Mixer Tank Agitators and Mixers

Product code 5549

4.3

## Please notice before ordering

The impeller tool is required for installation. The tool fits all sizes and only one is required. The sockets are different for MM338 and MM434  
 If in doubt please contact your Alfa Laval Technical Support

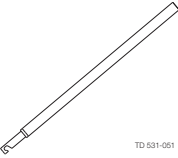
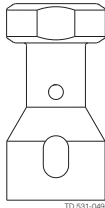
Item No.	RCPL [EUR]	Description	Tools
9634086437		Removal Tool Rod for MM338 and 434. Length 60mm / 24"	 TD 531-050
9634086352		Rod Extension MM338 and MM434. Length 90mm / 36"	 TD 531-051
9634086114 9634086147		Bearing socket MM338 Bearing socket MM434	 TD 531-049

Product code: 5504

**New range of agitators**

New wide range of Alfa Laval agitators replaces the LKR. The range includes 4 different types of sanitary agitators

ALT Alfa Laval Top mounted agitator  
 ALTB Alfa Laval Top mounted agitator with Bottom steady bearing  
 ALB Alfa Laval Bottom mounted agitator  
 ALS Alfa Laval Side mounted agitator

The agitator range is with its high hygienic standards targeted at sanitary applications. The high energy efficiency is however just as attractive to non-sanitary applications.

For any tank size the option of an agitator with low energy consumption is available.

All agitators are built using the same basic modules in various sizes. Selecting an ALS agitator is possible by means of the following tables. Please notice that the tables represent only a limited range of the available configurations.

Direct replacement of the LKR-5 is possible but the available range may offer a more efficient solution when selected based on tank size and product.

For configurations not included in the ordering leaflet please use the Enquiry Form available from your local Alfa Laval office.

Precondition of selecting ALS	
Application:	Selection: Choose the agitator from the list by tank volume interval. Note: The tank height/diameter ratio must be lower than 4 - if the ratio is higher, please contact Alfa Laval.
Duty:	For keeping the media homogeneous/agitation (agitation time for homogenous media: max. 15 min) - typical for storage tanks
Media(s):	Milk, pasteurized milk, recombined milk, raw milk, skim milk, whey, wine, juices, etc. Note: No heavy particles in the media
Viscosity:	Max.
Specific gravity (kg/dm <sup>3</sup> ):	Max. 1.1
Temperature (° C):	Max. 95 (CIP temperature)
Tank Shape:	H Tank/øID < 4

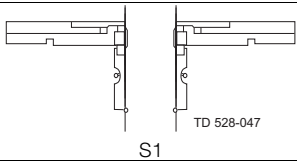
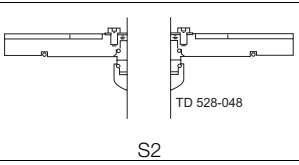
 <p>S1 TD 528-047</p>	 <p>S2 TD 528-048</p>
O-ring seal against tank flange, drain, oil trap (only geared versions) and shaft seal: single mechanical BELLOWS SEAL	O-ring seal against tank flange, drain, oil trap (only geared versions) and shaft seal: single mechanical none bellow seal

Product code: 5504

4.3

Direct Drive (50 Hz) Viscosity 0-10cP				Tank Size		Geared Drive (50 Hz) Viscosity 0-10cP						
Item No.	Voltage (V)	(rpm)	Power (kW)	<	>	Power (kW)	(rpm)	Voltage (V)	Seal	Lan-tern	Item No.	
TE68A2608100040	3x220-240/ 3x380-420	910	0.75	<	> 2.5 ≤ 7.0	>	0.25	283	3x220-240/ 3x380-420	S1	no	TE68A2608100650
											yes	TE68A2608100690
				<	> 7.0 ≤ 8.0	>	0.37	289	3x220-240/ 3x380-420	S2	no	TE68A2608100810
											yes	TE68A2608100850
TE68A2608100040	3x220-240/ 3x380-420	910	0.75	<	> 7.0 ≤ 8.0	>	0.37	289	3x220-240/ 3x380-420	S1	no	TE68A2608100970
											yes	TE68A2608101010
				<	> 8.0 ≤ 9.0	>	0.37	289	3x220-240/ 3x380-420	S2	no	TE68A2608101130
											yes	TE68A2608101170
TE68A2608100120	3x220-240/ 3x380-420	910	0.75	<	> 8.0 ≤ 9.0	>	0.37	289	3x220-240/ 3x380-420	S1	no	TE68A2608100970
											yes	TE68A2608101010
				<	> 8.0 ≤ 10.5	>	0.37	289	3x220-240/ 3x380-420	S2	no	TE68A2608101130
											yes	TE68A2608101170
TE68A2608100120	3x220-240/ 3x380-420	910	0.75	<	> 8.0 ≤ 10.5	>	0.37	289	3x220-240/ 3x380-420	S1	no	TE68A2608100970
											yes	TE68A2608101010
				<	> 10.5 ≤ 14.0	>	0.37	289	3x220-240/ 3x380-420	S2	no	TE68A2608101130
											yes	TE68A2608101170
TE68A2608100120	3x220-240/ 3x380-420	910	0.75	<	> 10.5 ≤ 14.0	>	0.37	289	3x220-240/ 3x380-420	S1	no	TE68A2608100970
											yes	TE68A2608101010
				<	> 14.0 ≤ 18.0	>	0.55	285	3x220-240/ 3x380-420	S2	no	TE68A2608101450
											yes	TE68A2608101490
TE68A2608100200	3x220-240/ 3x380-420	910	1.1	<	> 14.0 ≤ 18.0	>	0.55	285	3x220-240/ 3x380-420	S1	no	TE68A2608101290
											yes	TE68A2608101330
				<	> 18.0 ≤ 25.0	>	0.55	285	3x220-240/ 3x380-420	S2	no	TE68A2608101450
											yes	TE68A2608101490
TE68A2608100200	3x220-240/ 3x380-420	910	1.1	<	> 18.0 ≤ 25.0	>	0.55	285	3x220-240/ 3x380-420	S1	no	TE68A2608101290
											yes	TE68A2608101330
				<	> 25.0 ≤ 30.0	>	0.55	228	3x220-240/ 3x380-420	S2	no	TE68A2608101650
											yes	TE68A2608101810
TE68A2608100280	3x220-240/ 3x380-420	940	2.2	<	> 25.0 ≤ 30.0	>	0.55	228	3x220-240/ 3x380-420	S1	no	TE68A2608101610
											yes	TE68A2608101650
				<	> 30.0 ≤ 33.0	>	0.55	228	3x220-240/ 3x380-420	S2	no	TE68A2608101770
											yes	TE68A2608101810
TE68A2608100280	3x220-240/ 3x380-420	940	2.2	<	> 30.0 ≤ 33.0	>	0.55	228	3x220-240/ 3x380-420	S1	no	TE68A2608101930
											yes	TE68A2608101970
				<	> 33.0 ≤ 40.0	>	0.55	228	3x220-240/ 3x380-420	S2	no	TE68A2608102090
											yes	TE68A2608102130
TE68A2608100280	3x220-240/ 3x380-420	940	2.2	<	> 33.0 ≤ 40.0	>	0.55	228	3x220-240/ 3x380-420	S1	no	TE68A2608101930
											yes	TE68A2608101970
				<	> 40.0 ≤ 50.0	>	0.55	228	3x220-240/ 3x380-420	S2	no	TE68A2608102090
											yes	TE68A2608102130
TE68A2608100360	3x380-420/ 3x660-690	960	4.0	<	> 40.0 ≤ 50.0	>	0.55	228	3x220-240/ 3x380-420	S1	no	TE68A2608101930
											yes	TE68A2608101970
				<	> 50.0 ≤ 52.0	>	0.75	214	3x220-240/ 3x380-420	S2	no	TE68A2608102570
											yes	TE68A2608102610
TE68A2608100360	3x380-420/ 3x660-690	960	4.0	<	> 50.0 ≤ 52.0	>	0.75	214	3x220-240/ 3x380-420	S1	no	TE68A2608102570
											yes	TE68A2608102610
				<	> 52.0 ≤ 55.0	>	0.75	214	3x220-240/ 3x380-420	S2	no	TE68A2608102730
											yes	TE68A2608102770

Product code: 5504

DirectDrive (50 Hz) Viscosity 0-10cP				Tank Size	GearedDrive (50 Hz) Viscosity 0-10cP								
Item No.	Voltage (V)	(rpm)	Power (kW)		(m³)	Power (kW)	(rpm)	Voltage (V)	Seal	Lan-tern	Item No.		
TE68A2608100360	3x380-420/ 3x660-690	960	4.0	<	> 55.0 ≤ 80.0	>	0.75	214	3x220-240/ 3x380-420	S1	no	TE68A2608102570	
											yes	TE68A2608102610	
											S2	no	TE68A2608102730
												yes	TE68A2608102770
TE68A2608100360	3x380-420/ 3x660-690	960	4.0	<	> 80.0 ≤ 95.0	>	1.5	234	3x220-240/ 3x380-420	S1	no	TE68A2608103210	
											yes	TE68A2608103250	
											S2	no	TE68A2608103370
												yes	TE68A2608103410
TE68A2608100440	3x380-420/ 3x660-690	960	5.5	<	> 95.0 ≤ 135.0	>	1.5	234	3x220-240/ 3x380-420	S1	no	TE68A2608103210	
											yes	TE68A2608103250	
											S2	no	TE68A2608103370
												yes	TE68A2608103410
TE68A2608100440	3x380-420/ 3x660-690	960	5.5	<	> 135.0 ≤ 140.0	>	2.2	242	3x220-240/ 3x380-420	S1	no	TE68A2608103850	
											yes	TE68A2608103890	
											S2	no	TE68A2608104010
												yes	TE68A2608104050
TE68A2608100440	3x380-420/ 3x660-690	960	5.5	<	> 140.0 ≤ 170.0	>	2.2	242	3x220-240/ 3x380-420	S1	no	TE68A2608103850	
											yes	TE68A2608103890	
											S2	no	TE68A2608104010
												yes	TE68A2608104050
TE68A2608100440	3x380-420/ 3x660-690	960	5.5	<	> 170.0 ≤ 185.0	>	2.2	242	3x220-240/ 3x380-420	S1	no	TE68A2608103850	
											yes	TE68A2608103890	
											S2	no	TE68A2608104010
												yes	TE68A2608104050
TE68A2608100520	3x380-420/ 3x660-690	960	11	<	> 185.0 ≤ 195.0	>	3.0	241	3x220-240/ 3x380-420	S1	no	TE68A2608104490	
											yes	TE68A2608104530	
											S2	no	TE68A2608104650
												yes	TE68A2608104690
TE68A2608100520	3x380-420/ 3x660-690	960	11	<	> 195.0 ≤ 200.0	>	3.0	241	3x220-240/ 3x380-420	S1	no	TE68A2608104490	
											yes	TE68A2608104530	
											S2	no	TE68A2608104650
												yes	TE68A2608104690
TE68A2608100520	3x380-420/ 3x660-690	960	11	<	> 200.0 ≤ 265.0	>	3.0	241	3x220-240/ 3x380-420	S1	no	TE68A2608104490	
											yes	TE68A2608104530	
											S2	no	TE68A2608104650
												yes	TE68A2608104690
TE68A2608100520	3x380-420/ 3x660-690	960	11	<	> 265.0 ≤ 280.0	>	4.0	276	3x380-420/ 3x660-690	S1	no	TE68A2608105130	
											yes	TE68A2608105170	
											S2	no	TE68A2608105290
												yes	TE68A2608105330
TE68A2608100520	3x380-420/ 3x660-690	960	11	<	> 280.0 ≤ 300.0	>	4.0	276	3x380-420/ 3x660-690	S1	no	TE68A2608105130	
											yes	TE68A2608105170	
											S2	no	TE68A2608105290
												yes	TE68A2608105330
TE68A2608100520	3x380-420/ 3x660-690	960	11	<	> 300.0 ≤ 320.0	>	4.0	276	3x380-420/ 3x660-690	S1	no	TE68A2608105130	
											yes	TE68A2608105170	
											S2	no	TE68A2608105290
												yes	TE68A2608105330

Product code: 5504

4.3

Direct Drive (50 Hz) Viscosity 10-50cP				Tank Size		Geared Drive (50 Hz) Viscosity 10-50cP						
Item No.	Voltage (V)	(rpm)	Power (kW)	<	>	Power (kW)	(rpm)	Voltage (V)	Seal	Lan-tern	Item No.	
TE68A2608100040	3x220-240/ 3x380-420	910	0.75	<	> 2.5 ≤ 5.0	>	0.25	283	3x220-240/ 3x380-420	S1	no	TE68A2608100650
											yes	TE68A2608100690
				<	> 5.0 ≤ 8.0	>	0.37	289	3x220-240/ 3x380-420	S2	no	TE68A2608100810
											yes	TE68A2608100850
TE68A2608100120	3x220-240/ 3x380-420	910	0.75	<	> 5.0 ≤ 8.0	>	0.37	289	3x220-240/ 3x380-420	S1	no	TE68A2608100970
											yes	TE68A2608101010
				<	> 8.0 ≤ 12.0	>	0.37	289	3x220-240/ 3x380-420	S2	no	TE68A2608101130
											yes	TE68A2608101170
TE68A2608100200	3x220-240/ 3x380-420	910	1.1	<	> 8.0 ≤ 12.0	>	0.37	289	3x220-240/ 3x380-420	S1	no	TE68A2608100970
											yes	TE68A2608101010
				<	> 12.0 ≤ 18.0	>	0.55	285	3x220-240/ 3x380-420	S2	no	TE68A2608101130
											yes	TE68A2608101170
TE68A2608100200	3x220-240/ 3x380-420	910	1.1	<	> 12.0 ≤ 18.0	>	0.55	285	3x220-240/ 3x380-420	S1	no	TE68A2608101290
											yes	TE68A2608101330
				<	> 18.0 ≤ 25.0	>	0.55	228	3x220-240/ 3x380-420	S2	no	TE68A2608101450
											yes	TE68A2608101490
TE68A2608100280	3x220-240/ 3x380-420	940	2.2	<	> 18.0 ≤ 25.0	>	0.55	228	3x220-240/ 3x380-420	S1	no	TE68A2608101610
											yes	TE68A2608101650
				<	> 25.0 ≤ 35.0	>	0.55	228	3x220-240/ 3x380-420	S2	no	TE68A2608101770
											yes	TE68A2608101810
TE68A2608100280	3x220-240/ 3x380-420	940	2.2	<	> 25.0 ≤ 35.0	>	0.55	228	3x220-240/ 3x380-420	S1	no	TE68A2608101930
											yes	TE68A2608101970
				<	> 35.0 ≤ 55.0	>	0.75	214	3x220-240/ 3x380-420	S2	no	TE68A2608102090
											yes	TE68A2608102130
TE68A2608100360	3x380-420/ 3x660-690	960	4.0	<	> 35.0 ≤ 55.0	>	0.75	214	3x220-240/ 3x380-420	S1	no	TE68A2608102570
											yes	TE68A2608102610
				<	> 55.0 ≤ 75.0	>	0.75	214	3x220-240/ 3x380-420	S2	no	TE68A2608102730
											yes	TE68A2608102770
TE68A2608100360	3x380-420/ 3x660-690	960	4.0	<	> 55.0 ≤ 75.0	>	0.75	214	3x220-240/ 3x380-420	S1	no	TE68A2608102570
											yes	TE68A2608102610
				<	> 75.0 ≤ 105.0	>	1.5	234	3x220-240/ 3x380-420	S2	no	TE68A2608102730
											yes	TE68A2608102770
TE68A2608100440	3x380-420/ 3x660-690	960	5.5	<	> 75.0 ≤ 105.0	>	1.5	234	3x220-240/ 3x380-420	S1	no	TE68A2608103210
											yes	TE68A2608103250
				<	> 105.0 ≤ 135.0	>	1.5	234	3x220-240/ 3x380-420	S2	no	TE68A2608103370
											yes	TE68A2608103410
TE68A2608100440	3x380-420/ 3x660-690	960	5.5	<	> 105.0 ≤ 135.0	>	1.5	234	3x220-240/ 3x380-420	S1	no	TE68A2608103210
											yes	TE68A2608103250
				<	> 135.0 ≤ 170.0	>	2.2	242	3x220-240/ 3x380-420	S2	no	TE68A2608103370
											yes	TE68A2608103410
TE68A2608100440	3x380-420/ 3x660-690	960	5.5	<	> 135.0 ≤ 170.0	>	2.2	242	3x220-240/ 3x380-420	S1	no	TE68A2608103850
											yes	TE68A2608103890
				<	> 170.0 ≤ 230.0	>	3.0	241	3x220-240/ 3x380-420	S2	no	TE68A2608104010
											yes	TE68A2608104050
TE68A2608100520	3x380-420/ 3x660-690	960	11	<	> 170.0 ≤ 230.0	>	3.0	241	3x220-240/ 3x380-420	S1	no	TE68A2608104490
											yes	TE68A2608104530
				<	> 230.0 ≤ 300.0	>	4.0	276	3x380-420/ 3x660-690	S2	no	TE68A2608104650
											yes	TE68A2608104690
TE68A2608100520	3x380-420/ 3x660-690	960	11	<	> 230.0 ≤ 300.0	>	4.0	276	3x380-420/ 3x660-690	S1	no	TE68A2608105130
											yes	TE68A2608105170
				<	> 230.0 ≤ 300.0	>	4.0	276	3x380-420/ 3x660-690	S2	no	TE68A2608105290
											yes	TE68A2608105330

Product code: 5504

DirectDrive (60 Hz) Viscosity 0-10cP				Tank Size		GearedDrive (60 Hz) Viscosity 0-10cP						
Item No.	Voltage (V)	(rpm)	Power (kW)	<	>	Power (kW)	(rpm)	Voltage (V)	Seal	Lan-tern	Item No.	
TE68A2608100040	3x250-280/ 3x440-480	1092	0.9	<	> 2.5 ≤ 7.0	>	0.29	340	3x250-280/ 3x440-480	S1	no	TE68A2608100650
											yes	TE68A2608100690
										S2	no	TE68A2608100810
											yes	TE68A2608100850
TE68A2608100040	3x250-280/ 3x440-480	1092	0.9	<	> 7.0 ≤ 8.0	>	0.29	340	3x250-280/ 3x440-480	S1	no	TE68A2608100650
											yes	TE68A2608100690
										S2	no	TE68A2608100810
											yes	TE68A2608100850
TE68A2608100040	3x250-280/ 3x440-480	1092	0.9	<	> 8.0 ≤ 9.0	>	0.29	340	3x250-280/ 3x440-480	S1	no	TE68A2608100650
											yes	TE68A2608100690
										S2	no	TE68A2608100810
											yes	TE68A2608100850
TE68A2608100040	3x250-280/ 3x440-480	1092	0.9	<	> 8.0 ≤ 10.5	>	0.43	347	3x250-280/ 3x440-480	S1	no	TE68A2608100970
											yes	TE68A2608101010
										S2	no	TE68A2608101130
											yes	TE68A2608101170
TE68A2608100120	3x250-280/ 3x440-480	1092	0.9	<	> 10.5 ≤ 14.0	>	0.43	347	3x250-280/ 3x440-480	S1	no	TE68A2608100970
											yes	TE68A2608101010
										S2	no	TE68A2608101130
											yes	TE68A2608101170
TE68A2608100120	3x250-280/ 3x440-480	1092	0.9	<	> 14.0 ≤ 18.0	>	0.43	347	3x250-280/ 3x440-480	S1	no	TE68A2608100970
											yes	TE68A2608101010
										S2	no	TE68A2608101130
											yes	TE68A2608101170
TE68A2608100200	3x250-280/ 3x440-480	1092	1.32	<	> 18.0 ≤ 25.0	>	0.63	342	3x250-280/ 3x440-480	S1	no	TE68A2608101290
											yes	TE68A2608101330
										S2	no	TE68A2608101450
											yes	TE68A2608101490
TE68A2608100200	3x250-280/ 3x440-480	1092	1.32	<	> 25.0 ≤ 30.0	>	0.63	274	3x250-280/ 3x440-480	S1	no	TE68A2608101610
											yes	TE68A2608101650
										S2	no	TE68A2608101770
											yes	TE68A2608101810
TE68A2608100200	3x250-280/ 3x440-480	1092	1.32	<	> 30.0 ≤ 33.0	>	0.63	274	3x250-280/ 3x440-480	S1	no	TE68A2608101610
											yes	TE68A2608101650
										S2	no	TE68A2608101770
											yes	TE68A2608101810
TE68A2608100280	3x250-280/ 3x440-480	1128	2.6	<	> 33.0 ≤ 40.0	>	0.63	226	3x250-280/ 3x440-480	S1	no	TE68A2608102250
											yes	TE68A2608102290
										S2	no	TE68A2608102410
											yes	TE68A2608102450
TE68A2608100280	3x250-280/ 3x440-480	1128	2.6	<	> 40.0 ≤ 50.0	>	0.63	226	3x250-280/ 3x440-480	S1	no	TE68A2608102250
											yes	TE68A2608102290
										S2	no	TE68A2608102410
											yes	TE68A2608102450
TE68A2608100280	3x250-280/ 3x440-480	1128	2.6	<	> 50.0 ≤ 52.0	>	0.63	226	3x250-280/ 3x440-480	S1	no	TE68A2608102250
											yes	TE68A2608102290
										S2	no	TE68A2608102410
											yes	TE68A2608102450
TE68A2608100280	3x250-280/ 3x440-480	1128	2.6	<	> 52.0 ≤ 55.0	>	0.86	211	3x250-280/ 3x440-480	S1	no	TE68A2608102890
											yes	TE68A2608102930
										S2	no	TE68A2608103050
											yes	TE68A2608103090

Product code: 5504

4.3

DirectDrive (60 Hz) Viscosity 0-10cP				Tank Size (m <sup>3</sup> )	GearedDrive (60 Hz) Viscosity 0-10cP							
Item No.	Voltage (V)	(rpm)	Power (kW)		Power (kW)	(rpm)	Voltage (V)	Seal	Lan-tern	Item No.		
TE68A2608100360	3x440-480	1152	4.8	<	> 55.0 ≤ 80.0	>	0.86	211	3x250-280/ 3x440-480	S1	no	TE68A2608102890
											yes	TE68A2608102930
										S2	no	TE68A2608103050
											yes	TE68A2608103090
TE68A2608100360	3x440-480	1152	4.8	<	> 80.0 ≤ 95.0	>	1.73	242	3x250-280/ 3x440-480	S1	no	TE68A2608103530
											yes	TE68A2608103570
										S2	no	TE68A2608103690
											yes	TE68A2608103710
TE68A2608100360	3x440-480	1152	4.8	<	> 95.0 ≤ 135.0	>	1.73	242	3x250-280/ 3x440-480	S1	no	TE68A2608103530
											yes	TE68A2608103570
										S2	no	TE68A2608103690
											yes	TE68A2608103730
TE68A2608100360	3x440-480	1152	4.8	<	> 135.0 ≤ 140.0	>	1.73	242	3x250-280/ 3x440-480	S1	no	TE68A2608103530
											yes	TE68A2608103570
										S2	no	TE68A2608103690
											yes	TE68A2608103730
TE68A2608100360	3x440-480	1152	4.8	<	> 140.0 ≤ 170.0	>	2.53	251	3x250-280/ 3x440-480	S1	no	TE68A2608104170
											yes	TE68A2608104210
										S2	no	TE68A2608104330
											yes	TE68A2608104370
TE68A2608100600	3x440-480	1152	13.2	<	> 170.0 ≤ 185.0	>	2.53	251	3x250-280/ 3x440-480	S1	no	TE68A2608104170
											yes	TE68A2608104210
										S2	no	TE68A2608104330
											yes	TE68A2608104370
TE68A2608100600	3x440-480	1152	13.2	<	> 185.0 ≤ 195.0	>	2.53	251	3x250-280/ 3x440-480	S1	no	TE68A2608104170
											yes	TE68A2608104210
										S2	no	TE68A2608104330
											yes	TE68A2608104370
TE68A2608100600	3x440-480	1152	13.2	<	> 195.0 ≤ 200.0	>	2.53	251	3x250-280/ 3x440-480	S1	no	TE68A2608104170
											yes	TE68A2608104210
										S2	no	TE68A2608104330
											yes	TE68A2608104370
TE68A2608100600	3x440-480	1152	13.2	<	> 200.0 ≤ 265.0	>	3.45	227	3x250-280/ 3x440-480	S1	no	TE68A2608104810
											yes	TE68A2608104850
										S2	no	TE68A2608104970
											yes	TE68A2608105010
TE68A2608100600	3x440-480	1152	13.2	<	> 265.0 ≤ 280.0	>	3.45	227	3x250-280/ 3x440-480	S1	no	TE68A2608104810
											yes	TE68A2608104850
										S2	no	TE68A2608104970
											yes	TE68A2608105010
TE68A2608100600	3x440-480	1152	13.2	<	> 280.0 ≤ 300.0	>	4.6	275	3x440-480	S1	no	TE68A2608105450
											yes	TE68A2608105490
										S2	no	TE68A2608105610
											yes	TE68A2608105650
NA				<	> 300.0 ≤ 320.0	>	4.6	275	3x440-480	S1	no	TE68A2608105450
											yes	TE68A2608105490
										S2	no	TE68A2608105610
											yes	TE68A2608105650



Product code: 5504

DirectDrive (60 Hz) Viscosity 10-50cP				Tank Size (m <sup>3</sup> )	GearedDrive (60 Hz) Viscosity 10-50cP						
Item No.	Voltage (V)	(rpm)	Power (kW)		Power (kW)	(rpm)	Voltage (V)	Seal	Lan-tern	Item No.	
TE68A2608100040	3x250-280/ 3x440-480	1092	0.9	< > 2.5 ≤ 5.0 >	0.29	340	3x250-280/ 3x440-480	S1	no	TE68A2608100650	
									yes	TE68A2608100690	
								S2	no	TE68A2608100810	
									yes	TE68A2608100850	
TE68A2608100120	3x250-280/ 3x440-480	1092	0.9	< > 5.0 ≤ 8.0 >	0.43	347	3x250-280/ 3x440-480	S1	no	TE68A2608100970	
									yes	TE68A2608101010	
								S2	no	TE68A2608101130	
									yes	TE68A2608101170	
TE68A2608100200	3x250-280/ 3x440-480	1092	1.32	< > 8.0 ≤ 12.0 >	0.43	347	3x250-280/ 3x440-480	S1	no	TE68A2608100970	
									yes	TE68A2608101010	
								S2	no	TE68A2608101130	
									yes	TE68A2608101170	
TE68A2608100200	3x250-280/ 3x440-480	1092	1.32	< > 12.0 ≤ 18.0 >	0.63	342	3x250-280/ 3x440-480	S1	no	TE68A2608101290	
									yes	TE68A2608101330	
								S2	no	TE68A2608101450	
									yes	TE68A2608101490	
TE68A2608100280	3x250-280/ 3x440-480	1128	2.6	< > 18.0 ≤ 25.0 >	0.63	274	3x250-280/ 3x440-480	S1	no	TE68A2608101610	
									yes	TE68A2608101650	
								S2	no	TE68A2608101770	
									yes	TE68A2608101810	
TE68A2608100280	3x250-280/ 3x440-480	1128	2.6	< > 25.0 ≤ 35.0 >	0.63	226	3x250-280/ 3x440-480	S1	no	TE68A2608102250	
									yes	TE68A2608102290	
								S2	no	TE68A2608102410	
									yes	TE68A2608102450	
TE68A2608100360	3x440-480	1152	4.8	< > 35.0 ≤ 55.0 >	0.86	211	3x250-280/ 3x440-480	S1	no	TE68A2608102890	
									yes	TE68A2608102930	
								S2	no	TE68A2608103050	
									yes	TE68A2608103090	
TE68A2608100360	3x440-480	1152	4.8	< > 55.0 ≤ 75.0 >	0.86	211	3x250-280/ 3x440-480	S1	no	TE68A2608102890	
									yes	TE68A2608102930	
								S2	no	TE68A2608103050	
									yes	TE68A2608103090	
TE68A2608100360	3x440-480	1152	4.8	< > 75.0 ≤ 105.0 >	1.73	242	3x250-280/ 3x440-480	S1	no	TE68A2608103530	
									yes	TE68A2608103570	
								S2	no	TE68A2608103690	
									yes	TE68A2608103730	
TE68A2608100360	3x440-480	1152	4.8	< > 105.0 ≤ 135.0 >	1.73	242	3x250-280/ 3x440-480	S1	no	TE68A2608103530	
									yes	TE68A2608103570	
								S2	no	TE68A2608103690	
									yes	TE68A2608103730	
TE68A2608100360	3x440-480	1152	4.8	< > 135.0 ≤ 170.0 >	2.53	251	3x250-280/ 3x440-480	S1	no	TE68A2608104170	
									yes	TE68A2608104210	
								S2	no	TE68A2608104330	
									yes	TE68A2608104370	
TE68A2608100600	3x440-480	1152	13.2	< > 170.0 ≤ 230.0 >	3.45	227	3x250-280/ 3x440-480	S1	no	TE68A2608104810	
									yes	TE68A2608104850	
								S2	no	TE68A2608104970	
									yes	TE68A2608105010	
TE68A2608100600	3x440-480	1152	13.2	< > 230.0 ≤ 300.0 >	4.6	275	3x440-480	S1	no	TE68A2608105450	
									yes	TE68A2608105490	
								S2	no	TE68A2608105610	
									yes	TE68A2608105650	

Product code: 5504

4.3

Item No.	RCPL EUR	Tank flange	S	C	M	A	øB	øF	øD	øP	DirectDrive - S1 Sealing arrangement - With Lantern	
TE68A2608100040		ø250*	350	477	435	150	295	200	30	175		
TE68A2608100120		ø250*	350	477	435	150	295	200	30	200		
TE68A2608100200		ø250*	350	477	435	150	295	200	30	225		
TE68A2608100280		ø300*	450	485	471	200	295	250	30	250		
TE68A2608100360		ø300*	450	596	566	200	345	250	30	300		
TE68A2608100440		ø300*	450	596	566	260	345	250	30	350		
TE68A2608100520		ø400*	500	750	720	130	395	350	40	400		
TE68A2608100600		ø400*	500	750	720	130	395	350	40	350		
<b>GearedDrive - S1 Sealing arrangement - Without Lantern</b>												
TE68A2608100650		ø250*	475	523	496	124	345	200	35	300		
TE68A2608100970		ø250*	475	523	496	124	345	200	35	350		
TE68A2608101290		ø250*	475	523	496	124	345	200	35	400		
TE68A2608101610		ø250*	500	523	496	124	345	200	35	450		
TE68A2608101930		ø250*	500	523	496	124	345	200	35	500		
TE68A2608102250		ø250*	500	523	496	124	345	200	35	500		
TE68A2608102570		ø250*	500	561	539	142	345	200	35	550		
TE68A2608102890		ø250*	500	561	539	142	345	200	35	550		
TE68A2608103210		ø250*	500	687	648	147	345	200	35	600		
TE68A2608103530		ø250*	500	687	648	147	345	200	35	600		
TE68A2608103850		ø300*	700	950	898	169	410	250	35	650		
TE68A2608104170		ø300*	700	950	898	169	410	250	35	650		
TE68A2608104490		ø300*	700	950	898	169	410	250	35	700		
TE68A2608104810		ø300*	700	950	898	169	410	250	35	700		
TE68A2608105130		ø300*	700	950	921	179	410	250	35	700		
TE68A2608105450		ø300*	700	950	921	179	410	250	35	700		
<b>Without Lantern - S2 Sealing arrangement Without Lantern</b>												
TE68A2608100810		ø250*	475	523	496	124	345	200	30	300		
TE68A2608101130		ø250*	475	523	496	124	345	200	30	350		
TE68A2608101450		ø250*	475	523	496	124	345	200	30	400		
TE68A2608101770		ø250*	500	523	496	124	345	200	30	450		
TE68A2608102090		ø250*	500	523	496	124	345	200	30	500		
TE68A2608102410		ø250*	500	523	496	124	345	200	30	500		
TE68A2608102730		ø250*	500	561	539	142	345	200	30	550		
TE68A2608103050		ø250*	500	561	539	142	345	200	30	550		
TE68A2608103370		ø250*	500	687	648	147	345	200	30	600		
TE68A2608103690		ø250*	500	687	648	147	345	200	30	600		
TE68A2608104010		ø300*	700	950	898	169	410	250	40	650		
TE68A2608104330		ø300*	700	950	898	169	410	250	40	650		
TE68A2608104650		ø300*	700	950	898	169	410	250	40	700		
TE68A2608104970		ø300*	700	950	898	169	410	250	40	700		
TE68A2608105290		ø300*	700	950	921	179	410	250	40	700		
TE68A2608105610		ø300*	700	950	921	179	410	250	40	700		
<b>*Other Options Product code: 5508</b>												
TE2603023190							Welding flanges for tank connection			ø250		
TE2603022590										ø300		
TE2603050080										ø400		

Product code: 5504

Item No.	RCPL EUR	Tank flange	S	C	M	A	øB	øF	øD	øP	GearedDrive - S1 Sealing arrangement - With Lantern
TE68A2608100690		ø250*	475	623	596	124	345	200	35	300	
TE68A2608101010		ø250*	475	623	596	124	345	200	35	350	
TE68A2608101330		ø250*	475	623	596	124	345	200	35	400	
TE68A2608101650		ø250*	500	623	596	124	345	200	35	450	
TE68A2608101970		ø250*	500	623	596	124	345	200	35	500	
TE68A2608102290		ø250*	500	623	596	124	345	200	35	500	
TE68A2608102610		ø250*	500	661	639	142	345	200	35	550	
TE68A2608102930		ø250*	500	661	639	142	345	200	35	550	
TE68A2608103250		ø250*	500	787	748	147	345	200	35	600	
TE68A2608103570		ø250*	500	787	748	147	345	200	35	600	
TE68A2608103890		ø300*	700	1050	998	169	410	250	35	650	
TE68A2608104210		ø300*	700	1050	998	169	410	250	35	650	
TE68A2608104530		ø300*	700	1050	998	169	410	250	35	700	
TE68A2608104850		ø300*	700	1050	998	169	410	250	35	700	
TE68A2608105170		ø300*	700	1050	1021	179	410	250	35	700	
TE68A2608105490		ø300*	700	1050	1021	179	410	250	35	700	
GearedDrive - S2 Sealing arrangement - With Lantern											
TE68A2608100850		ø250*	475	623	596	124	345	200	30	300	
TE68A2608101170		ø250*	475	623	596	124	345	200	30	350	
TE68A2608101490		ø250*	475	623	596	124	345	200	30	400	
TE68A2608101810		ø250*	500	623	596	124	345	200	30	450	
TE68A2608102130		ø250*	500	623	596	124	345	200	30	500	
TE68A2608102450		ø250*	500	623	596	124	345	200	30	500	
TE68A2608102770		ø250*	500	661	639	142	345	200	30	550	
TE68A2608103090		ø250*	500	661	639	142	345	200	30	550	
TE68A2608103410		ø250*	500	787	748	147	345	200	30	600	
TE68A2608103730		ø250*	500	787	748	147	345	200	30	600	
TE68A2608104050		ø300*	700	1050	998	169	410	250	40	650	
TE68A2608104370		ø300*	700	1050	998	169	410	250	40	650	
TE68A2608104690		ø300*	700	1050	998	169	410	250	40	700	
TE68A2608105010		ø300*	700	1050	998	169	410	250	40	700	
TE68A2608105330		ø300*	700	1050	1021	179	410	250	40	700	
TE68A2608105650		ø300*	700	1050	1021	179	410	250	40	700	

*Other Options Product code: 5508							
TE2603023190						Welding flanges for tank connection	ø250
TE2603022590							ø300
TE2603050080							ø400

Product code: 5504

4.3

ALS Standard configuration	
<b>Technical Data</b> Surface finish: Prepared for frequency duties with: Motor Protection Class Motor Color GearedDrive Propellers	Mechanical polish Ra<0.8 µm PTC (Thermistors) IP55 RAL 5010 Coaxial gear 3- bladed Energy Saving Foils (EnSaFoil)
<b>Material:</b> Bearing house Mounting flange Product contact parts (Stainless steel) Product contact parts (Rubber parts) Mechanical Sealing (DirectDrive) Mechanical Sealing (GearedDrive)	Stainless steel AISI 316L AISI 316L EPDM / FEP Carbon (FDA) / Silicium Carbide Silicium Carbide / Silicium Carbide

			Options
RCPL EUR	Motor size [kW]	Description	
		Material certificates 3.1 acc. EN 10204 (for parts with product contact) including FDA Conformity statement acc. 21 CFR 177 for gaskets and elastomers	
<b>Food approved oil USDA-H1 - Add-on price (Only geared models)</b>			
	0.25 - 0.75 1.1 - 2.2 3.0 to 4.0		
<b>Stainless Steel Motor Cover - Add on price (geared models)</b>			
	0.25 - 0.55 0.75 1.5 - 2.2 3.0 - 4.0		
<b>Stainless Steel Motor Cover - Add on price (direct drive models)</b>			
	0.75 - 1.1 2.2 4.0 - 5.5 11		

Product code: 5504

Options	
<p><b>ATEX</b> ATEXin tank ATEXoutside tank</p> 	<p>II1GDcTX, II2GDcTX or II3GDcTX II2GDcTX or II3GDcTX Agitators can be delivered approved for ATEX environment with declaration of conformity according to directive 94/9/EC, approved according to ATEX categories</p>
<p><b>Surface finish</b> Less Sanitary application For high Sanitary application</p>	<p>Shot peened propellers Mechanical polished with succeeding electropolish</p>
<p><b>Material</b> Product contact parts (Stainless steel) Product contact parts (Rubber parts) Mechanical Sealing (GearedDrive)</p>	<p>AISI 304L (Lower than standard), AISI 904L, SAF 2205 EPDM / FEP (Depending on product) Other options available</p>
<p><b>Various options</b> Voltage and Frequency: Seal Arrangements: Drive: Propellers:</p>	<p>All motors voltages and frequencies are available Many variations - see PD Sheet Type of drive unit. Ex. right angle gear 2- or 3- bladed Energy Saving Foils (EnSaFoil)</p>



# IM 10 Rotary Jet Mixer

# Tank Agitators and Mixers

Product code: 5509 Mixer  
 Product code: 5546 Welding Adaptor  
 Product code: 5548 Tools

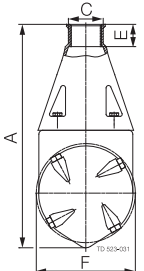
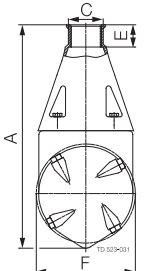
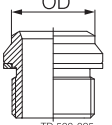

Surface treatment: Bright

4.3

Item No.	RCPL EUR	Flow at 5 bar m <sup>3</sup> /h	No. of Nozzles/ Dimension	Dimension (mm)				Connection
				A	C	E	F	
<b>PEEK</b>								
TE30B030		7	4 x ø3.9	230	36	16	100	
TE30B040		9.5	4 x ø4.6	230	36	16	100	
TE30B050		12	4 x ø5.5	230	36	16	100	
<b>PEEK</b>								
								<b>Thread (1" NPT-female)</b>
TE30N030		7	4 x ø3.9	230	36	16	100	
TE30N040		9.5	4 x ø4.6	230	36	16	100	
TE30N050		12	4 x ø5.5	230	36	16	100	
								<b>Welding adapter for IM 10</b>
TE52D030		1" Rp-male (BSP)/1" ISO thread pipe (OD = 33.7 mm)						
TE52D031		1" NPT-male/1" ANSI pipe (OD = 33.4 mm)						
TE52D032		1" Rp-male (BSP)/1 1/2" dairy pipe (OD = 38 mm) Gasket is included						
<b>Add-on prices</b>								
TE30B0XX-70		ATEX						
TE30N0XX-70		ATEX						
<b>Standard tool kit</b>								
TE81B085		Caliper (1 piece) Socket wrench with pin (1 piece) Spanner for IM 10, TJ20G and MultiJet 25 (1 piece) Spanner (1 piece)						
<b>Item No. explanation</b>								<b>Add-on explanation</b>
TE30B0XX-70		ATEX approved machine for use in explosive atmospheres.						
TE30N0XX-70		Category 1 for installation in zone 0/20 in accordance to Directive 94/9/EC. EX II 1 GD c T175°C Tamp 0°C to +140°C; Baseefa10ATEX0188X						

Product code: 5509 Mixer  
 Product code: 5546 Welding Adaptor  
 Product code: 5548 Tools

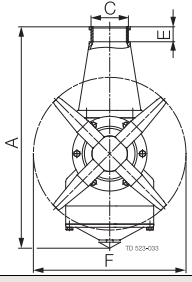
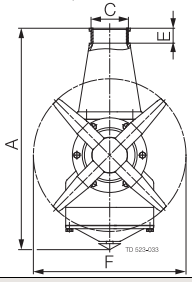
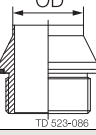
Surface finish: Bright

Item No.	RCPL EUR	Flow at 5 bar	No. of Nozzles/ Dimension	Guide	Dimension (mm)				Connection
					A	C	E	F	
<b>Stainless Steel</b>		m <sup>3</sup> /h							<b>Thread (1½" Rp-female (BSP))</b>
TE31B061		16	4 x ø6	100%	297	50	16	204	
TE31B071		19	4 x ø7	100%	297	50	16	204	
TE31B070		19	4 x ø7	0%	297	50	16	204	
TE31B080		22.5	4 x ø8	0%	297	50	16	204	
TE31B181		14	2 x ø8	100%	297	50	16	270	
TE31B182		19	2 x ø10	0%	297	50	16	270	
TE31B183		21	2 x ø11	0%	297	50	16	270	
									<b>Thread (1½" NPT-female)</b>
TE31B166		16	4 x ø6	100%	297	50	16	204	
TE31B167		19	4 x ø7	100%	297	50	16	204	
TE31B177		19	4 x ø7	0%	297	50	16	204	
TE31B178		22.5	4 x ø8	0%	297	50	16	204	
TE31B281		14	2 x ø8	100%	297	50	16	270	
TE31B282		19	2 x ø10	0%	297	50	16	270	
TE31B283		21	2 x ø11	0%	297	50	16	270	
		<b>Connection</b>							<b>Welding adapter for IM 15</b>
TE52D018		1½" Rp-male (BSP)/40 mm DIN pipe (OD = 40 mm)							
TE52D020		1½" Rp-male (BSP)/1½" ISO thread pipe (OD = 48.3 mm)							
TE52D021		1½" Rp-male (BSP)/2" dairy pipe (OD = 51 mm)							
<b>Add-on prices</b>									
TE31BXXX-70		ATEX							
<b>Standard tool kit</b>									
TE81B055		Unbraco key for 3/16" screw (1 piece) Screw driver Unbraco 5/32" (2 pieces) 8 mm socket wrench with pin (1 piece)							
<b>Special tools</b>									
TE81B033		Pusher for 1½" machines							
TE81B129		Pusher for collar bush, 1.5" gear frame							
TE81B130		Tool for upper collar							
<b>Item No. explanation</b>		<b>Add-on explanation</b>							
TE31BXXX-70		ATEX approved machine for use in explosive atmospheres. Category 1 for installation in zone 0/20 in accordance to Directive 94/9/EC. EX II 1 GD c T175°C Tamp 0°C to +140°C; Baseefa10ATEX0188X							



# IM 20 Rotary Jet Mixer

# Tank Agitators and Mixers

Product code: 5509 Mixer  
 Product code: 5546 Welding adapter  
 Product code: 5548 Tools

Surface finish: Bright

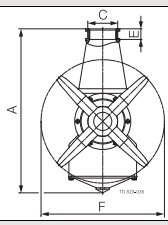
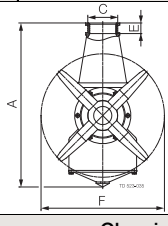
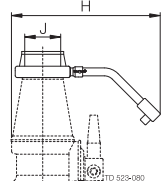
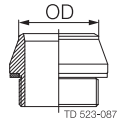

4.3

Item No.	RCPL EUR	Flow at 5 bar  m³/h	No. of Nozzles/ Dimension	Guide	Dimension (mm)				Connection					
					A	C	E	F						
<b>Stainless Steel</b>														
TE32B081		23	4 x ø8	100%	356	65	16	268						
TE32B091		27.5	4 x ø9	100%	356	65	16	268						
TE32B090		27.5	4 x ø9	0%	356	65	16	268						
TE32B100		32.5	4 x ø10	0%	356	65	16	268						
TE32B112		24	2 x ø12	0%	356	65	16	337						
TE32B113		28	2 x ø13	0%	356	65	16	337						
TE32B115		37	2 x ø15	0%	356	65	16	337						
<b>Thread (2" NPT-female (BSP))</b>														
TE32B181		23	4 x ø8	100%	356	65	16	268						
TE32B191		27.5	4 x ø9	100%	356	65	16	268						
TE32B190		27.5	4 x ø9	0%	356	65	16	268						
TE32B200		32.5	4 x ø10	0%	356	65	16	268						
TE32B212		24	2 x ø12	0%	356	65	16	337						
TE32B213		28	2 x ø13	0%	356	65	16	337						
TE32B215		37	2 x ø15	0%	356	65	16	337						
<b>Cleaning unit</b>														
TE52D140		Cleaning unit for IM 20, 2" Rp (BSP)					J	H						
TE52D240		Cleaning unit for IM 20, 2" NPT					2" Rp	210						
<b>Welding adapter for IM 20</b>														
TE52D025		2" Rp-male (BSP)/2" ISO thread pipe (OD = 60.3 mm)												
TE52D026		2" Rp-male (BSP)/2½" dairy pipe (OD = 63.5 mm) <b>Gasket is included</b>												
<b>Add-on prices</b>														
TE31BXXX-70		ATEX												
<b>Standard tool kit</b>														
TE81B055		Unbraco key for 3/16" screw (1 piece) Screw driver Unbraco 5/32" (2 pieces) Unbraco key for 1/4" screw (1 piece) Screw driver Unbraco 1/4" (1 piece) Caliper (1 piece) Socket wrench with pin (1 piece)												
<b>Special tools</b>														
TE81B031		Pusher for gear frame												
TE81B032		Fixture set for gear frame												
TE81B130		Tool for upper collar												
TE81B132		Tool for lower collar												
<b>Add-on explanation</b>														
TE32BXXX-70		ATEX approved machine for use in explosive atmospheres. Category 1 for installation in zone 0/20 in accordance to Directive 94/9/EC. EX II 1 GD c T175°C Tamp 0°C to +140°C; Baseefa10ATEX0188X												

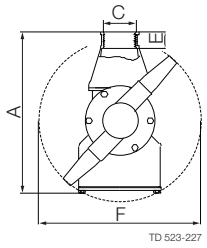

Product code: 5509 Mixer  
 Product code: 5548 Tools

Surface treatment: Bright

Item No.	RCPL EUR	Flow at 8 bar m <sup>3</sup> /h	No. of Nozzles/ Dimension	Guide	Dimension (mm)			Connection
					A	C	F	
Stainless Steel								Thread (2½" Rp-female (BSP))
TE33B034		38	2 x ø15	0%	286	80	337	
TE33B036		42	2 x ø17	0%	286	80	337	
TE33B038		51	2 x ø19	0%	286	80	337	
TE33B040		54	2 x ø21	0%	286	80	337	
<b>Add-on prices</b>								
TE33B0XX-70		ATEX						
<b>Standard tool kit</b>								
TE81B065		Unbraco key for 3/16" screw (1 piece) Screw driver Unbraco 5/32" (2 pieces) Unbraco key for 1/4" screw (1 piece) Screw driver Unbraco 1/4" (1 piece) Caliper (1 piece)						
<b>Special tools</b>								
TE81B031		Pusher for gear frame						
TE81B032		Fixture set for gear frame						
<b>Item No. explanation</b>								<b>Add-on explanation</b>
TE33B0XX-70		ATEX approved machine for use in explosive atmospheres. Category 1 for installation in zone 0/20 in accordance to Directive 94/9/EC. EX II 1 GD c T175°C Tamp 0°C to +140°C; Baseefa10ATEX0188X						

Other connection available on request