

HOBO® Pro v2 (Part # U23-00X)

Inside this package:

- HOBO Pro v2 logger
- Clamp and mounting screws



Doc #10694-D, MAN-U23
Onset Computer Corporation

Thank you for purchasing a HOBO data logger. With proper care, it will give you years of accurate, reliable measurements.

The HOBO Pro v2 logger's environmentally rugged case is designed for years of reliable use in outdoor applications. It has enough memory to record over 42,000 12-bit measurements. The U23-001 and U23-002 models also feature user-replaceable RH sensors.

The logger uses an optical USB communications interface (via a compatible shuttle or base station) for launching and reading out the logger. The optical interface allows the logger to be offloaded without compromising the electronics. The USB compatibility allows for easy setup and fast downloads.

HOBOWare® software version 2.2.1 or higher is required for logger operation. Visit www.onsetcomp.com for compatible software.

Specifications

Temperature Sensor	
Operation range	Internal sensors: -40° to 70°C (-40° to 158°F) U23-002 external temperature sensor: -40° to 70°C (-40° to 158°F) U23-003 and U23-004 external sensors: -40° to 100°C (-40° to 212°F), with tip and cable immersion in fresh water up to 50°C (122°F) for one year
Accuracy	0.2°C over 0° to 50°C (0.36°F over 32° to 122°F); see Plot A
Resolution	0.02°C at 25°C (0.04°F at 77°F); see Plot A
Response time (typical to 90%)	Internal sensors: 40 minutes in air moving 1 m/sec U23-002 external temperature sensor: 5 minutes in air moving 1 m/sec U23-003 and U23-004 external sensors: 3 minutes in air moving 1 m/sec; 30 seconds in stirred water
Stability (drift)	< 0.1°C (0.18°F) per year
Relative Humidity Sensor (U23-001, U23-002 only)	
Operation range	0-100% RH, -40° to 70°C (-40° to 158°F) Exposure to conditions below -20°C (-4°F) or above 95% RH may temporarily increase the maximum RH sensor error by an additional 1%
Accuracy	± 2.5% from 10 to 90%; see Plot B for full range
Resolution	0.03%
Response time (typical to 90%)	U23-001: 40 minute in air moving 1 m/sec with protective cap U23-002: 10 minutes in air moving 1 m/sec with protective cap
Stability (drift)	< 1% per year typical; hysteresis 1%
Logger	
Operation range	-40° to 70°C (-40° to 158°F)
Real-time clock	± 1 minute per month 0° to 50°C (32° to 122°F)
Battery	1/2 AA, 3.6 Volt lithium, user-replaceable (part # HP-B)
Battery life (typical use)	3 years with 1 minute or greater logging interval
Memory (non-volatile)	64K bytes memory (approx. 21,000 temperature and RH measurements)
Materials	All models: ASA styrene polymer housing and mounting clamp; polypropylene protective cap; Buna-N o-ring(s); U23-001, U23-002 only: ASA styrene polymer RH sensor cap; modified hydrophobic polyethersulfone membrane

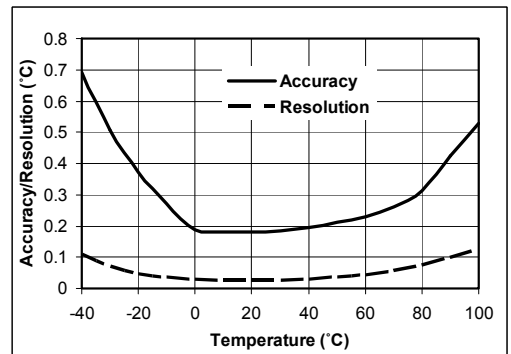

Plot A

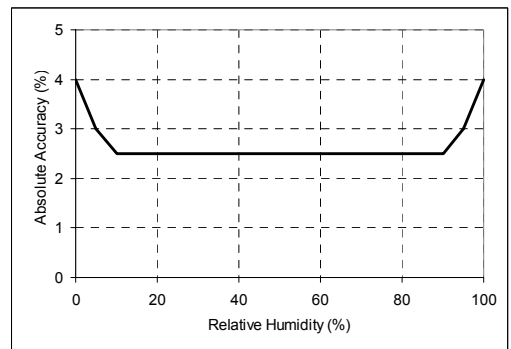

Plot B

(continued)

Cables	U23-001: No cables U23-002: One 184 cm (6 ft.) PVC cable; sensor diameter 1 cm (0.38 in.) U23-003: Two 184 cm (6 ft.) PVC cables; sensor diameter 0.5 cm (0.20 in.) U23-004: One 184 cm (6 ft.) PVC cable; sensor diameter 0.5 cm (0.20 in.)
Environmental rating	Electronics housing is NEMA 6P equivalent (tolerant of brief submergence); Units with RH sensors are NEMA 4 equivalent (splash-resistant)
Launch modes	Immediate start; delayed start
Logging interval	Fixed-rate or multiple logging intervals, with up to 8 user-defined logging intervals and durations; logging intervals from 1 second to 18 hours (refer to HOBOWare software manual)
Offload modes	Offload while logging; stop and offload
Battery indication	Battery voltage can be viewed in status screen and optionally logged in datafile. Low battery indication in datafile.
Weight	U23-001: 57 g (1.5 oz); U23-002: 118 g (3.1 oz); U23-003: 138 g (3.7 oz); U23-004: 102 g (2.7 oz)
Dimensions	Housing measures 10.2 × 3.8 cm (4.0 × 1.5 in.)
NIST certificate	Temperature certificate available for additional charge
CE	The CE Marking identifies this product as complying with the relevant directives in the European Union (EU).

Accessories available

- RH sensor replacement kit for U23-001 (part # HUM-RHPCB-1)
- RH sensor replacement kit for U23-002 (part # HUM-RHPCB-2)

Connecting the logger

The HOBOW Pro v2 requires a coupler (Part # COUPLER2-E) and USB-Optic Base Station (Part # BASE-U-4) or HOBOW Waterproof Shuttle (Part # U-DTW-1) to connect to the computer.

1. Install the logger software on your computer before proceeding.
2. Follow the instructions that came with your base station or shuttle to attach the base station or shuttle to a USB port on the computer.
3. Make sure the logger’s communications window is clean and dry. (Use a clean, nonabrasive cloth, if necessary.) If the logger is damp, wipe off excess moisture.
4. Attach the coupler to the base station or shuttle, then insert the logger into the coupler with the ridge on the logger aligned with the ridge on the coupler.

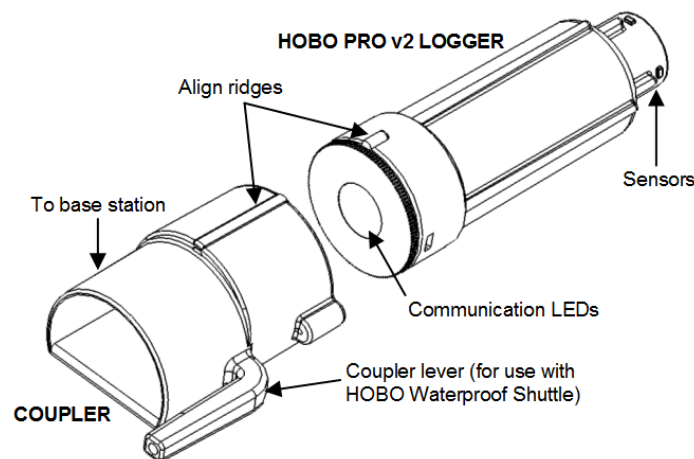

5. If you are using the HOBOW Waterproof Shuttle, briefly press the coupler lever to put the shuttle into base station mode.

6. If the logger has never been connected to the computer before, it may take a few seconds for the new hardware to be detected by the computer.
7. Use the logger software to launch the logger, check the logger’s status, read it out, stop it manually with the software, or let it continue to record data until the memory is full. Or, use the HOBOW Waterproof Shuttle to read out and relaunch the logger in the field.

Refer to the software user’s guide for complete details on launching, reading out, and viewing data from the logger.

Important: USB communications may not function properly at temperatures below 0°C (32°F) or above 50°C (122°F).

Note: The first time you launch the logger, the deployment number will be greater than zero. Onset launches the loggers to test them prior to shipping.

Operation

A light (LED) in the communications window of the logger confirms logger operation. (In brightly lit areas, it may be necessary to shade the logger to see the LED blink.) The following table explains when the light blinks during logger operation:

When:	The “OK” light:
The logger is logging	Blinks once every one to four seconds (the shorter the logging interval, the faster the light blinks); blinks when logging a sample
The logger is awaiting a start because it was launched in Start At Interval or Delayed Start mode	Blinks once every eight seconds until logging begins

Sample and event logging

The logger can record two types of data: samples and events. Samples are the sensor measurements recorded at each logging interval (for example, temperature every minute). Events are independent occurrences triggered by a logger activity, such as Bad Battery or Host Connected. Events help you determine what was happening while the logger was logging.

The logger stores 64K of data, and can record over 42,000 12-bit measurements.

Deploying and protecting the logger

- To clean the logger’s case, use a sponge with warm, soapy water.
- Use the included clamp to mount the logger to a surface. The clamp has two holes for the screws, 44 mm (1.7 inches) apart.

The clamp is slightly tapered to accommodate the logger. Install the clamp so the logger fits better with its communication window facing up. This will prevent condensation from pooling around the sensor and/or grommet.

- A solar shield is recommended if the logger will be exposed to sunshine.
- Periodically inspect the desiccant and dry it if it is not bright blue. The desiccant pack is located in the cap of the logger. To dry the desiccant, remove the desiccant pack from the cap and leave the pack in a warm, dry location until the bright blue color is restored. (Refer to the “Battery” section for instructions on removing and replacing the logger cap.)

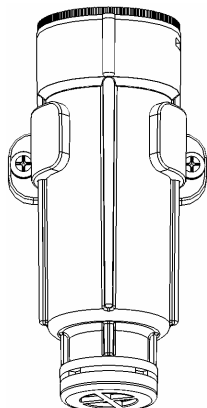

Temperature range (RH > 90%)	Desiccant maintenance schedule
Less than 30°C (86°F)	Approximately once per year
30° to 40°C (86° to 104°F)	Approximately every six months
Over 40°C (104°F)	Approximately every three months

Replacing the RH sensor

The RH sensor (on models U23-001 and U23-002) is protected by an ASA styrene polymer cap and a modified hydrophobic polyethersulfone fluid barrier membrane that allows vapor to penetrate while protecting the sensor from condensation.

RH sensor performance may degrade over time. To replace the RH sensor in your logger, refer to the diagram and instructions for your logger:

U23-001

1. Turn the sensor cap counter-clockwise slightly and pull to remove it.
2. Set the membrane aside. If the o-ring comes off, set it aside as well.

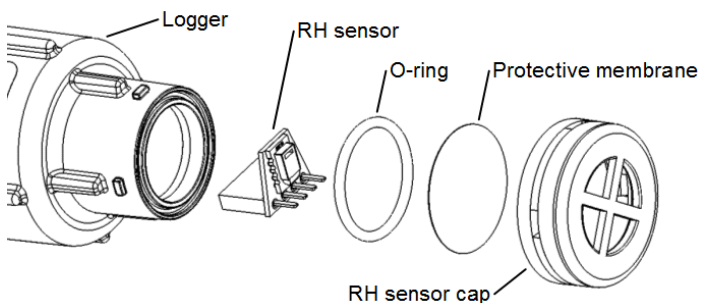

3. Note the orientation of the small circuit board containing the RH sensor. Using a pair of small pliers, pull it out and discard it.

4. Push gently but firmly to install the new sensor (Onset part # HUM-RHPCB-1) in the same orientation.
5. Make sure the o-ring is clean and seated properly, and set the protective membrane on top (either side can face up).
6. Put the sensor cap back on. Push down and turn it slightly clockwise to close it securely. Do not force it. If the cap does not go on easily, the sensor may be installed incorrectly. Check the sensor orientation and try again.

U23-002

1. Grasp the cap and membrane and pull firmly. Discard them.
2. Note the orientation of the small circuit board containing the RH sensor. Pull it out and discard it.

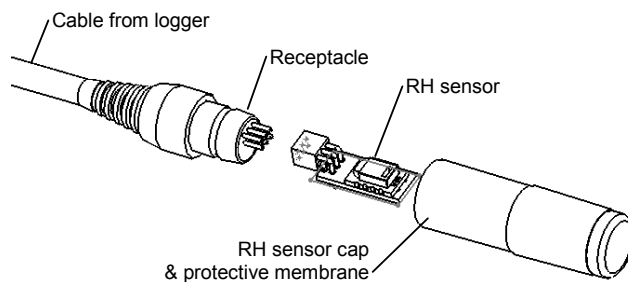

3. Push gently but firmly to install the new sensor (Onset part # HUM-RHPCB-2) in the same orientation.
4. Put the new sensor cap and membrane on. Do not force the cap. If it does not go on easily, the sensor may be installed backwards. Reverse the sensor and try again.

Battery

Typical battery life is about three years. Actual battery life is a function of the number of deployments, logging interval, and operation/storage temperature of the logger. To obtain a three-year battery life, use a logging interval of one minute or greater, and operate and store the logger at temperatures between 0° and 40°C (32° and 104°F).

Frequent deployments with logging intervals of less than one minute, and continuous storage/operation at temperatures above 40°C, will result in significantly lower battery life. For example, continuous logging at a one-second logging interval will result in a battery life of approximately one month.

The logger can report and log its own battery voltage. If the battery falls below 3.1 V, the logger will record a “bad battery” event in the datafile. If the datafile contains “bad battery” events, or if logged battery voltage repeatedly falls below 3.3 V, the battery is failing and should be replaced before the next deployment. To change the battery:

1. Turn slightly counter-clockwise and pull to remove the protective cap. Loosen the cable grommet on the opposite end, if the logger has an external sensor.
2. Carefully pull out the circuit board containing the battery. (If the logger has an external sensor, you will probably find it easier to push the cable(s) into the case to push the circuit board out.)
3. Examine the desiccant packs that were packed into the case. If the desiccant is not bright blue, put the desiccant packs in a warm, dry place until the blue color is restored.

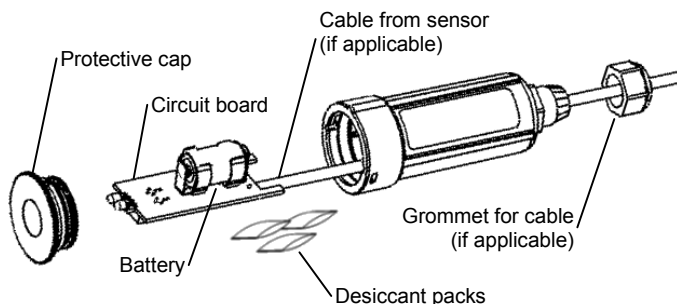

4. Install a new 1/2 AA, 3.6 Volt lithium battery (part # HP-B). The positive end of the battery should face towards the communication LEDs.
5. Use a clean, dry cloth to wipe away any moisture inside the case.

6. Push the board and the desiccant packs back into the case, taking care not to bend the communication LEDs. Align the board with the grooves inside the case. (If you try to put the board in upside-down, the battery will get in the way.)
7. Make sure o-ring on the protective cap is still in place. It should not be pinched, twisted, or trapping dirt or lint, which could interfere with the protective cap.
8. Line up the bumps on the protective cap with the notches in the logger's case. Push and turn the cap slightly clockwise. Pull the slack in the sensor cable(s) and-tighten the grommet, if applicable.

⚠ WARNING: Do not cut open, incinerate, heat above 100°C (212°F), or recharge the lithium battery. The battery may explode if the logger is exposed to extreme heat or conditions that could damage or destroy the battery case. Do not dispose of the logger or battery in fire. Do not expose the contents of the battery to water. Dispose of the battery according to local regulations for lithium batteries.

Service and Support

As part of Onset's ongoing efforts to provide 100% customer satisfaction, our Continuing Engineering Group constantly monitors and evaluates all of our products and software. In the unlikely event any significant defect is found, Onset will notify you. If you find a defect, please e-mail us at loggerhelp@onsetcomp.com.

HOBO products are easy to use and reliable. In the unlikely event that you have a problem with this instrument, contact the company where you bought the logger: Onset or an Onset Authorized Dealer. Before calling, you can evaluate and often solve the problem if you write down the events that led to the problem (are you doing anything differently?) and if you visit the Technical Support section of the Onset web site at www.onsetcomp.com/support.html. When contacting Onset, ask for technical support and be prepared to provide the product number and serial number for the logger and software version in question. Also completely describe the problem or question. The more information you provide, the faster and more accurately we will be able to respond.

Onset Computer Corporation
 470 MacArthur Blvd., Bourne, MA 02532
 Mailing: PO Box 3450, Pocasset, MA 02559-3450
 Phone: 1-800-LOGGERS (1-800-564-4377) or 508-759-9500
 Fax: 508-759-9100
 E-mail: loggerhelp@onsetcomp.com
 Internet: www.onsetcomp.com

Warranty

Onset Computer Corporation (Onset) warrants to the original end-user purchaser for a period of **one year** from the date of original purchase that the HOBOb® product(s) purchased will be free from defect in material and workmanship. During the warranty period Onset will, at its option, either repair or replace products that prove to be defective in material or workmanship. This warranty shall terminate and be of no further effect at the time the product is (1) damaged by extraneous cause such as fire, water, lightning, etc. or not maintained in accordance with the accompanying documentation; (2) modified; (3) improperly installed; (4) repaired by someone other than Onset; or (5) used in a manner or purpose for which the product was not intended.

THERE ARE NO WARRANTIES BEYOND THE EXPRESSED WARRANTY ABOVE. IN NO EVENT SHALL ONSET BE LIABLE FOR LOSS OF PROFITS OR INDIRECT, CONSEQUENTIAL, INCIDENTAL, SPECIAL OR OTHER SIMILAR DAMAGES ARISING OUT OF ANY BREACH OF THIS CONTRACT OR OBLIGATIONS UNDER THIS CONTRACT, INCLUDING BREACH OF WARRANTY, NEGLIGENCE, STRICT LIABILITY, OR ANY OTHER LEGAL THEORY.

Limitation of Liability. The Purchaser's sole remedy and the limit of Onset's liability for any loss whatsoever shall not exceed the Purchaser's price of the product(s). The determination of suitability of products to the specific needs of the Purchaser is solely the Purchaser's responsibility. **THERE ARE NO WARRANTIES BEYOND THE EXPRESSED WARRANTY OFFERED WITH THIS PRODUCT. EXCEPT AS SPECIFICALLY PROVIDED IN**

THIS DOCUMENT, THERE ARE NO OTHER WARRANTIES EXPRESS OR IMPLIED, INCLUDING BUT NOT LIMITED TO, ANY IMPLIED WARRANTIES OF MERCHANTABILITY OR FITNESS FOR A PARTICULAR PURPOSE. NO INFORMATION OR ADVICE GIVEN BY ONSET, ITS AGENTS OR EMPLOYEES SHALL CREATE A WARRANTY OR IN ANY WAY INCREASE THE SCOPE OF THE EXPRESSED WARRANTY OFFERED WITH THIS PRODUCT.

Indemnification. Products supplied by Onset are not designed, intended, or authorized for use as components intended for surgical implant or ingestion into the body or other applications involving life-support, or for any application in which the failure of the Onset-supplied product could create or contribute to a situation where personal injury or death may occur. Products supplied by Onset are not designed, intended, or authorized for use in or with any nuclear installation or activity. Products supplied by Onset are not designed, intended, or authorized for use in any aeronautical or related application. Should any Onset-supplied product or equipment be used in any application involving surgical implant or ingestion, life-support, or where failure of the product could lead to personal injury or death, or should any Onset-supplied product or equipment be used in or with any nuclear installation or activity, or in or with any aeronautical or related application or activity, Purchaser will indemnify Onset and hold Onset harmless from any liability or damage whatsoever arising out of the use of the product and/or equipment in such manner.

Returns

Please direct all warranty claims and repair requests to place of purchase.

Before returning a failed unit directly to Onset, you must obtain a Return Merchandise Authorization (RMA) number from Onset. You must provide proof that you purchased the Onset product(s) directly from Onset (purchase order number or Onset invoice number). Onset will issue an RMA number that is valid for 30 days. You must ship the product(s), properly packaged against further damage, to Onset (at your expense) with the RMA number marked clearly on the outside of the package. Onset is not responsible for any package that is returned without a valid RMA number or for the loss of the package by any shipping company. Loggers must be clean before they are sent back to Onset or they may be returned to you.

Repair Policy

Products that are returned after the warranty period or are damaged by the customer as specified in the warranty provisions can be returned to Onset with a valid RMA number for evaluation.

ASAP Repair Policy. For an additional charge, Onset will expedite the repair of a returned product.

Data-back™ Service. HOBOb data loggers store data in nonvolatile EEPROM memory. Onset will, if possible, recover your data.

Tune Up Service. Onset will examine and retest any HOBOb data logger.

© 2006 Onset Computer Corporation. All rights reserved.

Part #: MAN-U23, Doc #: 10694-D, Patent #: 6,826,664

Onset, HOBOb, and HOBObware are registered trademarks of Onset Computer Corporation. Other products and brand names may be trademarks or registered trademarks of their respective owners.