



# AXIAL EXPLOSION PROOF FANS

## EB Ex-ATEX CESI approval N.03 ATEX 251



- Explosion Proof certified Axial Fans for wall or panel mounting to convey air directly outside or through a short duct compliance to ATEX Directive 94/9/EEC effective in European Community from July 1st 2003. These products are a safe choice for many applications in commercial and industrial environment where the risk of explosion is high and where the surrounding atmosphere contains gas, vapors or steam highly inflammable.

- The whole product and not just the electrical parts, has been certified by the Italian Notified Body CESI with certify number CESI n°03 ATEX 251.

- Reference standards: EN 13463-1: 2003 pr EN 14986: 2005.

- Fan group II, cat. 2 for gases, construction safety c, max surface temp. T4 (135°C).

- Classified for zones 1 and 2.

- This omologation has required specific safety tests and proper examinations on products to verify how the introduced solutions have satisfied the essential Directive requirements.

- Body built in metal sheet epoxy painted. Impeller statically and dynamically balanced in high resistance polymeric material, V0 self extinguishing material with high electrical conductivity properties.

- Available flow rates from 900 to 4500 m<sup>3</sup>/h.

- Motor EEXd-II B - T4, IP 55 protected supplied with cable gland for cables from Ø10 up to Ø11,5 mm.

- Working temperature: -20 + 40 °C.

### Reversibility:

- All models.

### Dimensions

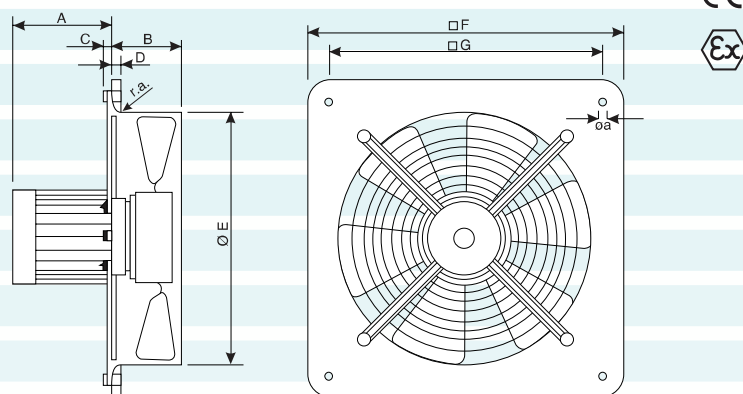

Model	A	B	C	D	E	F	G	r.a.	ø a	Kg
<b>EB 25 4M Ex-ATEX</b>	205	70	9	8	260	340	290	15	7	10
<b>EB 25 4T Ex-ATEX</b>	205	70	9	8	260	340	290	15	7	9
<b>EB 30 4M Ex-ATEX</b>	205	70	9	10	312	390	340	15	9	10
<b>EB 30 4T Ex-ATEX</b>	205	70	9	10	312	390	340	15	9	9
<b>EB 35 4M Ex-ATEX</b>	205	85	10	12	365	460	410	15	9	11
<b>EB 35 4T Ex-ATEX</b>	205	85	10	12	365	460	410	15	9	10
<b>EB 40 4M Ex-ATEX</b>	205	85	10	12	415	510	460	15	11	12
<b>EB 40 4T Ex-ATEX</b>	205	85	10	12	415	510	460	15	11	11
<b>EB 50 4M Ex-ATEX</b>	205	90	10	15	515	630	580	15	11	14
<b>EB 50 4T Ex-ATEX</b>	205	90	10	15	515	630	580	15	11	13

- In accordance with the essential requirements of 89/392/CE Directive concerning machines and with European Standards EN 292 part I e II, EN 294 and IEC 204-1 and 2.

### Technical Data

Model	Rif.	Marking	Motor	Flow rate m <sup>3</sup> /h	Max press. mm H <sub>2</sub> O	N° Poles	W	Nominal curr. in A.		dB (A) 2 m	RPM
								at 230V	400V		
<b>EB 25 4M Ex-ATEX</b>	OW 354 3	II 2G c T4	single-phase	900	10	4	120	0,70	-	55	1460
<b>EB 25 4T Ex-ATEX</b>	OW 357 6	II 2G c T4	three-phase	900	10	4	100	0,67	0,39	55	1460
<b>EB 30 4M Ex-ATEX</b>	OW 355 0	II 2G c T4	single-phase	1500	8,3	4	140	0,75	-	59	1400
<b>EB 30 4T Ex-ATEX</b>	OW 359 2	II 2G c T4	three-phase	1500	8,3	4	125	0,69	0,40	59	1430
<b>EB 35 4M Ex-ATEX</b>	OW 356 8	II 2G c T4	single-phase	2250	10	4	160	0,80	-	62	1350
<b>EB 35 4T Ex-ATEX</b>	OW 360 0	II 2G c T4	three-phase	2250	10	4	150	0,72	0,42	63	1400
<b>EB 40 4M Ex-ATEX</b>	OW 350 1	II 2G c T4	single-phase	2900	9	4	180	0,85	-	65	1290
<b>EB 40 4T Ex-ATEX</b>	OW 361 8	II 2G c T4	three-phase	2900	9	4	180	0,74	0,43	66	1350
<b>EB 50 4M Ex-ATEX</b>	OW 351 9	II 2G c T4	single-phase	4500	14	4	210	1,00	-	70	1200
<b>EB 50 4T Ex-ATEX</b>	OW 362 6	II 2G c T4	three-phase	4500	14	4	230	0,78	0,45	72	1270