

Ex-protected portable power supply units

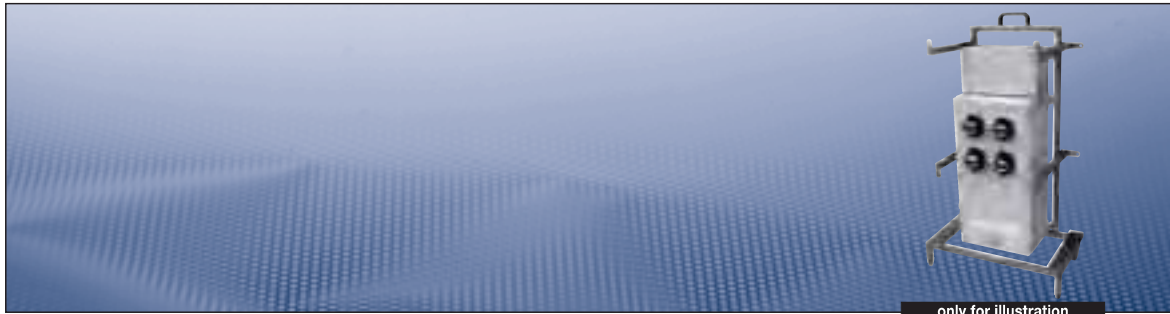

Technical data

Ex-protected portable power supply EXKO 233201 A0006

Marking accd. to 94/9/EC	Ⓔ II 2 G Ex de IIC T4
EC-Type Examination Certificate	PTB 99 ATEX 1044
Permissible ambient temperature	-20 °C up to +40 °C
Rated voltage	230/24 V transformer, 100 VA
Rated current	16 A
Frequency	50 Hz
External back up fuse	16 A gL / gG
Insulation class	I
Degree of protection accd. to IEC 60529	IP65
Cable glands	1x M25 trumpet shaped cable gland, 1x M12 cable gland plastic
Enclosure material	glass-fibre reinforced polyester (option sheet steel, painted oder stainless steel AISI 316L) wall socket: glass-fibre reinforced polyester, plug: polyamide
Dimensions (H x W x D)	metal frame stainless steel, squared 20 x 20 x 2, with wheels 1062 x 500 x 336 mm
Weight	30 kg
Enclosure colour	black

Ordering details

Components	Components external	Order No.
1x MCB S202M - K0,5A, 10kA	2x receptacle	
1x FI-LS DS971 - C4A 0,03A, 10kA	16A 3-pole, 24V (GHG5420007R0003)	
1x transformer 230/24V 100VA	actuating flap for components	EXKO 233201 A0006

Option:

padlock facility for enclosure cover

Enclosure material sheet steel, painted oder stainless steel AISI 316L

Customized solution for connection cable, plugs & sockets and rated voltage

Dimension drawing

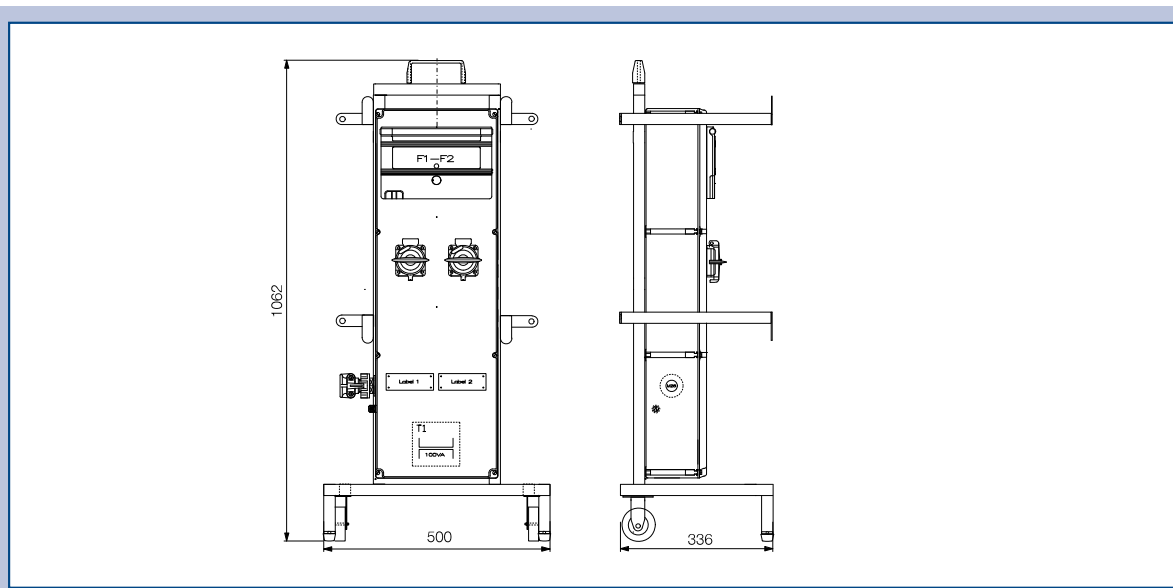

Dimensions in mm