





[View larger image](#)

[Printer Friendly Version](#)

Semi-Automatic Hydraulic Swivel Head Mitering

- ▣ Model Number : [SH-460M](#)
- ▣ Design Style : [Single Side Swivel/Hinge Type](#)

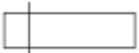
Specifications

| Angle | |  0° |  -45° |  -60° |
|-----------------------|--------------------|--|---|--|
| Max. Capacity | Round | 250 mm (10") | 230 mm (9") | 110 mm (4.3") |
| | Rectangular(H x W) | 230 x 460 mm (9" x 18.1") | 230 x 230 mm (9" x 9") | 230 x 110 mm (9" x 4.3") |
| Saw Blade | Speed(60Hz) | 29,46,65,98 m/min (95,150,213,321 fpm) | | |
| | Size (LxWxT) | 3505L x 27W x 0.9Tmm (138" x 1" x 0.035") | | |
| | Tension | Manual | | |
| Motor Output | Saw Blade | 2 HP (1.5 KW) | | |
| | Hydraulic | 1/4 HP (0.18 KW) | | |
| | Coolant pump | 1/8 HP (0.09 KW) | | |
| Tank Capacity | Hydraulic | 8 L (2.08 gal) | | |
| | Coolant | 40 L (10.4 gal) | | |
| Work Bed Height | | 645 mm (25.4") | | |
| Net Weight | | 550 kgs (1210 lbs) | | |
| Gross Weight | | 650 kgs (1430 lbs) | | |
| Floor Space(LxWxH) | | 1400 x 1900 x 1700 mm (55" x 74.8" x 66.9") | | |
| Shipping Space(LxWxH) | | 1855 x 1220 x 1170 mm (73" x 48" x 46") | | |

Machine Features

SH-460M Machine Features

Structure

- Oversized hydraulic cylinder with precision ground hinge support
- Specially designed heavy-duty cast iron swivel center for miter cuts from 90 to 45 degree
- Large rugged base with built-in coolant & hydraulic system

Blade Drive

- 2 hp motor, heavy-duty reducer, & variable step drive assembly
- 4-speed transmission with the best worm gear and shaft

Blade Guidance & Lubrication System

- Carbide blade guides with roller bearings
- Two additional bearings to support blade from the top
- Rigid guide arms mounted on extra wide precision ground dovetail slide
- Integral coolant system
- Blade brush

Control & Automation

- Down feed rate & cutting pressure control via hydraulic down feed valve
- Conveniently designed control station at chest level
- Built in hydraulic units for automatic head lift after cut-off
- Work height selector

Material Feeding & Clamping

- Cast iron vises
- Secure clamping via dependable manual lead screw system
- Anti-slip hand wheel

Safety

- Conduits protection measure
- Orange alert safety design

Standard Accessories

- Easy blade change with front access at waist level
- Bi-metal saw blade
- Tool box, leveling pads, and an additional wire brush
- Operation & parts manual

*All designs and specifications are subject to change without notice or obligation

 **Floor plan**

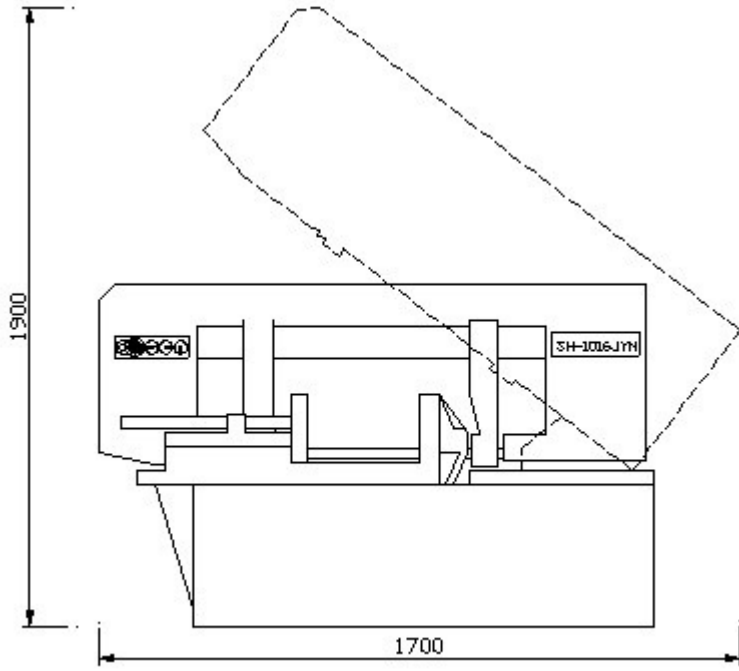
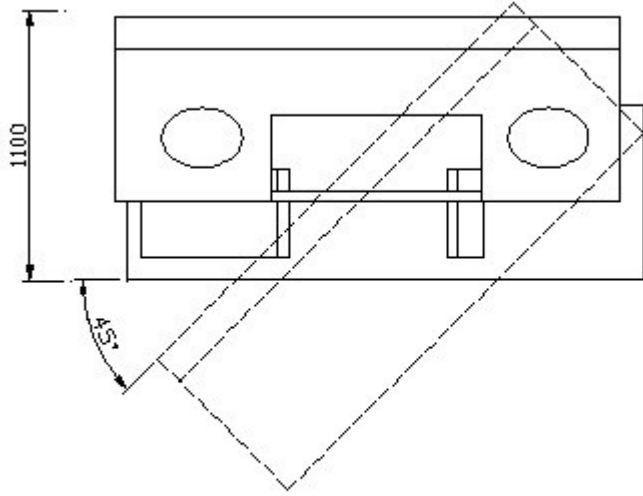

Close 