





[View larger image](#)

[Printer Friendly Version](#)

## Manual Swivel Head Mitering

- Model Number : **MH-500M**
- Design Style : **Single Side Swivel/Hinge Type**

### Specifications

Angle			 +45°	 +60°
Max. Capacity	Round	330 mm (13")	290 mm (11.5")	220 mm (8.7")
	Rectangular(H x W)	280 x 500 mm (11" x 19.7")	280 x 280 mm (11" x 11")	280 x 200 mm (11" x 7.9")
Saw Blade	Speed(60Hz)	23,36,51,76 m/min (75,117,166,247 fpm)		
	Size (LxWxT)	4150L x 27W x 0.9Tmm (163" x 1" x 0.035")		
	Tension	Spring loaded		
Motor Output	Saw Blade	3 HP (2.25 KW)		
	Hydraulic	---		
	Coolant pump	1/8 HP (0.09 KW)		
Tank Capacity	Hydraulic	---		
	Coolant	30 L (7.8 gal)		
Work Bed Height		820 mm (32.3")		
Net Weight		745 kgs (1639 lbs)		
Gross Weight		945 kgs (2079 lbs)		
Floor Space(LxWxH)		1870 x 2715 x 2085 mm (74" x 107" x 82")		
Shipping Space(LxWxH)		2260 x 1190 x 1700 mm (89" x 47" x 67")		

### Machine Features

## MH-500M Machine Features

#### Structure

- Swivel sawhead mitering from 90 to 60 degrees
- Rigid and heavy-duty pivot and trunion
- Sturdy cast work table
- 460mm (18") solid discharge table with coolant return

### **Blade Drive**

- Four blade speed with toggle clamp device
- Infinitely variable blade speed (option)

### **Blade Guidance & Lubrication System**

- Carbide blade guides with roller bearings
- Cast iron guide arm supported by heavy-duty cast iron dovetail
- Blade tension device
- Integral coolant system
- Synchronized blade brush

### **Control & Automation**

- Conveniently designed control station at waist level
- Hydraulic feed and rapid approach valve
- Electrical components located inside the control box with main lockout disconnect

### **Material Feeding & Clamping**

- Built in adjustable material stop
- Quick action cam lock vise

### **Safety**

- Interlock design in electrical and hydraulic system
- "Alert Orange" safety measure

### **Standard Accessories**

- Adjustable material stop
- Additional flushing hose
- Bi-metal saw blade
- Tool box, leveling pads, and an additional wire brush
- Operation & parts manual

Design and specifications are subject to change without notice and obligation.

 **Floor plan**

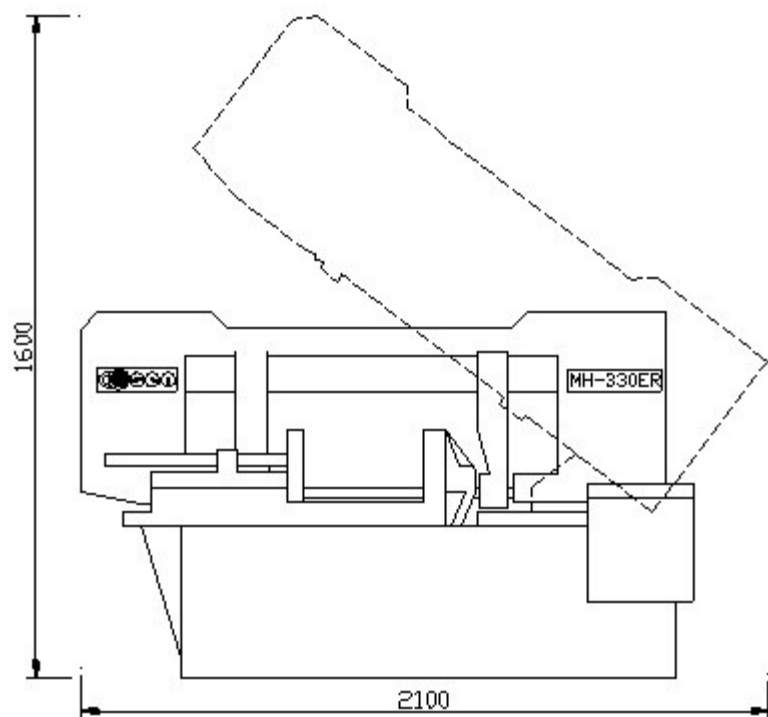
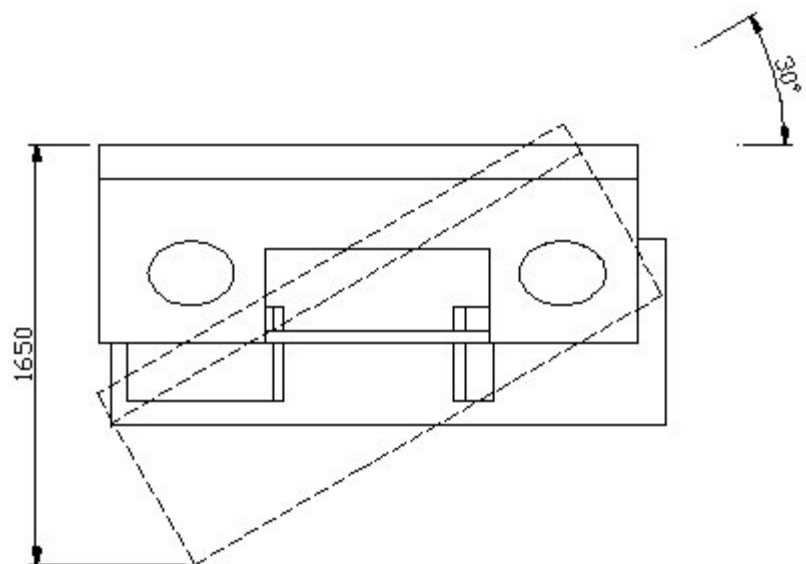

Close 