



Up to Category 4, EN 954-1 PNOZ XV2.1



Safety relay for monitoring E-STOP pushbuttons and safety gates.

Approvals

	PNOZ XV2.1
	◆
	◆
	◆

Unit features

- ▶ Positive-guided relay outputs:
 - 2 safety contacts (N/O), instantaneous
 - 2 safety contacts (N/O), delay-on de-energisation
- ▶ Connection options for:
 - E-STOP pushbutton
 - Safety gate limit switch
 - Reset button
- ▶ LED indicator for:
 - Switch status channel 1/2
 - Supply voltage
 - Reset circuit
- ▶ Delay-on de-energisation, fixed or selectable
- ▶ Delay time can be cancelled via reset button
- ▶ See order reference for unit types

The max. category the safety contacts can achieve in accordance with EN 954-1 is stated in the technical details.

Safety features

The relay conforms to the following safety criteria:

- ▶ The circuit is redundant with built-in self-monitoring.
- ▶ The safety function remains effective in the case of a component failure.
- ▶ The correct opening and closing of the safety function relays is tested automatically in each on-off cycle.
- ▶ The unit has an electronic fuse.

Unit description

The safety relay meets the requirements of EN 60204-1 and IEC 60204-1 and may be used in applications with

- ▶ E-STOP pushbuttons
- ▶ Safety gates

Block diagram

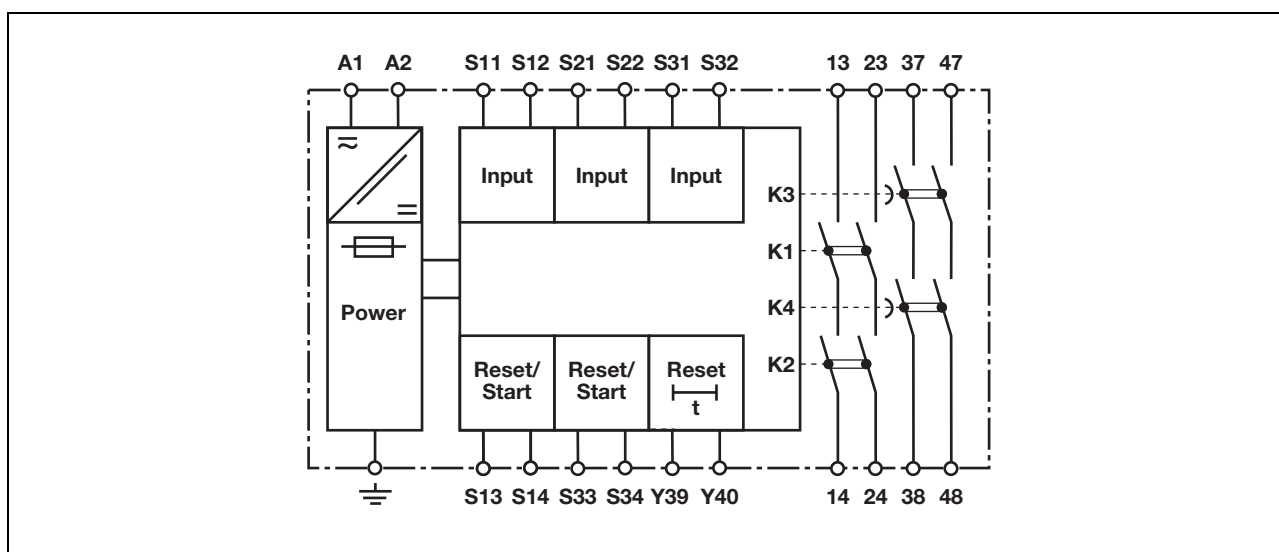

Up to Category 4, EN 954-1 PNOZ XV2.1

Function description

- ▶ Single-channel operation: no redundancy in the input circuit, earth faults in the reset circuit are detected.
- ▶ Dual-channel operation with detection of shorts across contacts: redundant input circuit, detects
 - earth faults in the reset and input circuit,
 - short circuits in the input circuit and, with a monitored reset, in the reset circuit too,
 - shorts between contacts in the input circuit.
- ▶ Automatic start: Unit is active once the input circuit has been closed.
- ▶ Monitored reset: Unit is active once the input circuit is closed and once the reset circuit is closed after the waiting period has elapsed (see technical details).
- ▶ Increase in the number of available contacts by connecting contact expander modules or external contactors/relays.

Timing diagram

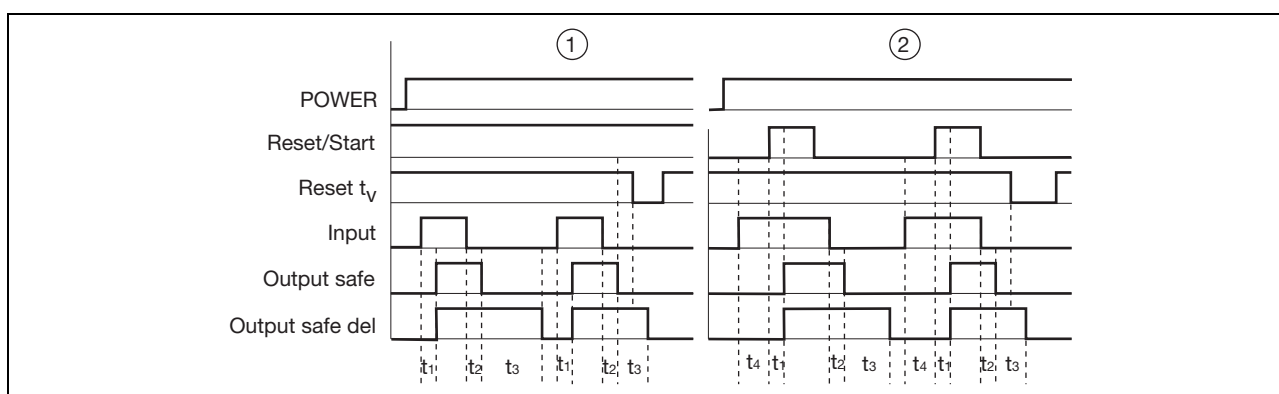

Key

- ▶ Power: Supply voltage
- ▶ Reset/start: Reset circuit S13-S14, S33-S34
- ▶ Reset t_v : Y39-Y40
- ▶ Input: Input circuits S11-S12, S21-S22, S31-S32
- ▶ Output safe: Safety contacts, instantaneous 13-14, 23-24
- ▶ Output safe del: Safety contacts, delayed 37-38, 47-48
- ▶ ①: Automatic reset
- ▶ ②: Monitored reset
- ▶ t_1 : Switch-on delay
- ▶ t_2 : Delay-on de-energisation
- ▶ t_3 : Delay time
- ▶ t_4 : Waiting period

Wiring

Please note:

- ▶ Information given in the “Technical details” must be followed.
- ▶ Outputs 13-14, 23-24 are instantaneous safety contacts, outputs 37-38, 47-48 are delay-on de-energisation safety contacts.
- ▶ To prevent contact welding, a fuse should be connected before the output contacts (see technical details).
- ▶ Calculation of the max. cable runs l_{max} in the input circuit:

$$l_{max} = \frac{R_{lmax}}{R_l / km}$$

R_{lmax} = max. overall cable resistance (see technical details)

R_l / km = cable resistance/km

- ▶ Use copper wire that can withstand 60/75 °C.

- ▶ Sufficient fuse protection must be provided on all output contacts with capacitive and inductive loads.

Up to Category 4, EN 954-1 PNOZ XV2.1

Preparing for operation

► Supply voltage

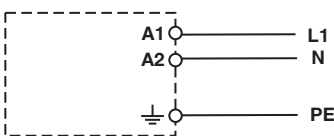
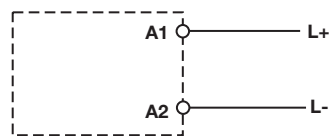
Supply voltage	AC	DC
		

► Input circuit

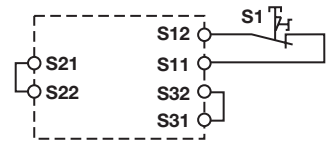
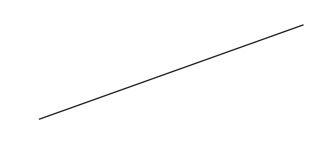
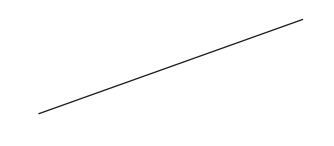
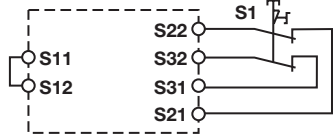
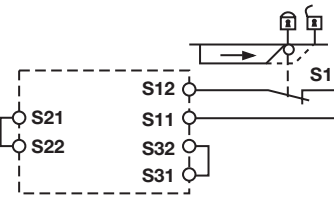
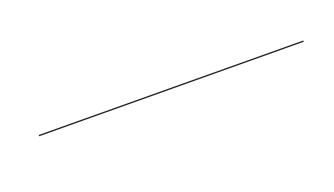
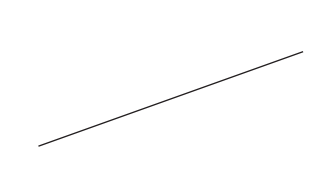
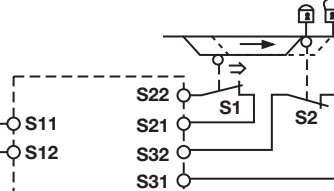
Input circuit	Single-channel	Dual-channel
E-STOP without detection of shorts across contacts		
E-STOP with detection of shorts across contacts		
Safety gate without detection of shorts across contacts		
Safety gate with detection of shorts across contacts		

Up to Category 4, EN 954-1 PNOZ XV2.1

▶ Reset circuit

Reset circuit	E-STOP wiring (single-channel) Safety gate (single-channel)	E-STOP wiring (dual-channel) Safety gate (dual-channel)
Automatic reset		
Monitored reset		



▶ Reset

Reset	Link	N/C contact for resetting the delay time
Link or N/C contact		

▶ Feedback loop

Feedback loop	Automatic reset	Monitored reset
Contacts from external contactors		

▶ Key

S1/S2	Two-hand button
S3	Reset button
	Switch operated
	Gate open
	Gate closed

Up to Category 4, EN 954-1 PNOZ XV2.1

Terminal configuration

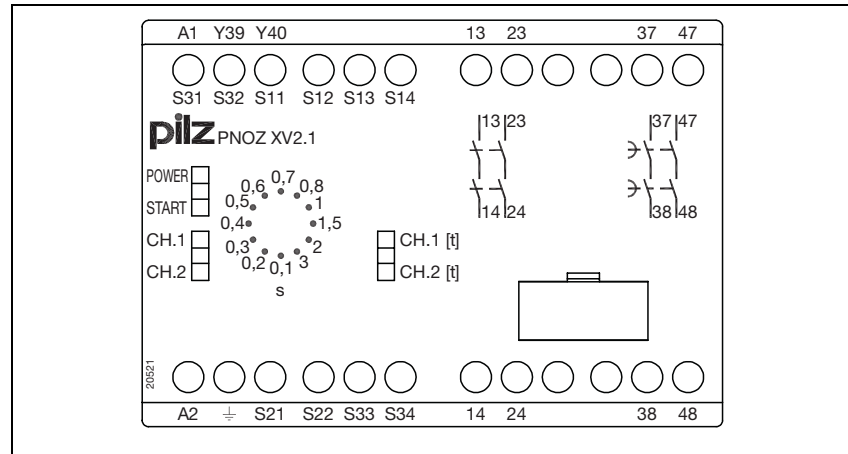

Installation

- ▶ The safety relay should be installed in a control cabinet with a protection type of at least IP54.
- ▶ Use the notch on the rear of the unit to attach it to a DIN rail.
- ▶ Ensure the unit is mounted securely on a vertical DIN rail (35 mm) by using a fixing element (e.g. retaining bracket or an end angle).

Dimensions

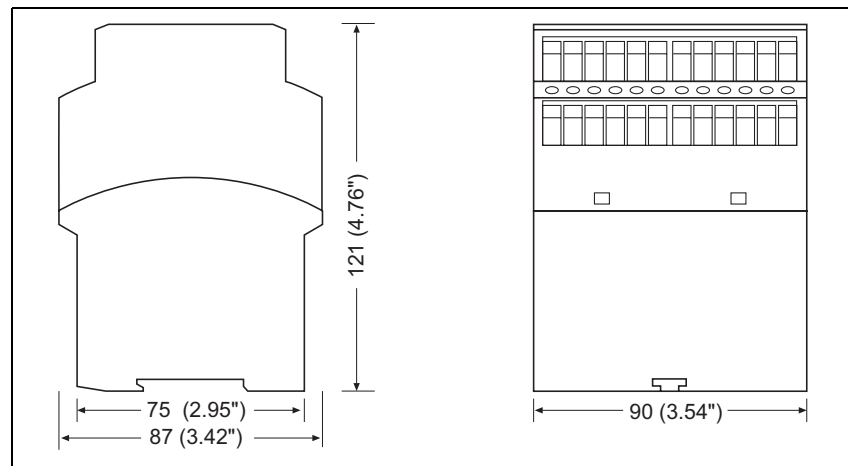

Notice

This data sheet is only intended for use during configuration. For installation and operation, please refer to the operating instructions supplied with the unit.

Service life graph

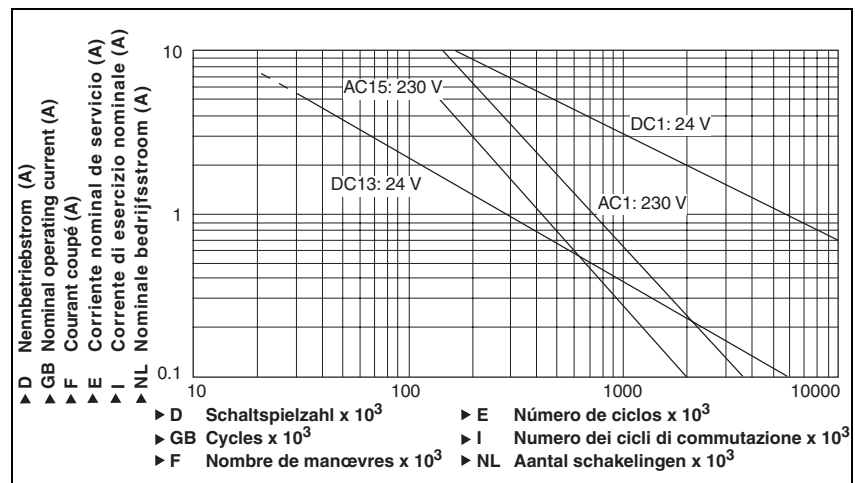

Up to Category 4, EN 954-1 PNOZ XV2.1

Technical details	
Electrical data	
Supply voltage U_B AC	24 - 240 V
Supply voltage U_B DC	24 - 240 V
Voltage tolerance	-15% / +10%
Power consumption at U_B AC	8.5 VA
Power consumption at U_B DC	5.0 W
Frequency range AC	50 - 60 Hz
Residual ripple DC	160 %
Voltage and current at input circuit: 24.0 VDC reset circuit: 24.0 VDC feedback loop: 24.0 VDC	35.0 mA 30.0 mA 3.1 mA
Output contacts in accordance with EN 954-1, Category 4	Safety contacts (N/O): 2 ST
Output contacts in accordance with EN 954-1 Category 1 Order no. 774550, 774558 Category 3	Safety contacts (N/O), delayed: 2 ST If delay time >30 s If delay time <30 s
Utilisation category in accordance with EN 60947-4-1 AC1: 240 V DC1: 24 V	$I_{min}: 0.01 A, I_{max}: 8.0 A$ $P_{max}: 2,000 VA$ $I_{min}: 0.01 A, I_{max}: 8.0 A$ $P_{max}: 200 W$
Utilisation category in accordance with EN 60947-5-1 AC15: 230 V DC13 (6 cycles/min): 24 V	$I_{max}: 5.0 A$ $I_{max}: 7.0 A$
Contact material	AgSnO₂ + 0.2 µm Au
External contact fuse protection (EN 60947-5-1) Blow-out fuse, quick Blow-out fuse, slow Circuit breaker	10 A 6 A 6 A, 24 VAC/DC, characteristic B/C
Max. overall cable resistance R_{lmax} input circuits, reset circuits	
Single-channel at U_B DC	200 Ohm
Single-channel at U_B AC	200 Ohm
Dual-channel with detect. of shorts across contacts at U_B DC	20 Ohm
Dual-channel with detect. of shorts across contacts at U_B AC	20 Ohm
Times	
Switch-on delay with automatic reset typ. with automatic reset max. with automatic reset after power on typ. with automatic reset after power on max. with monitored reset typ. with monitored reset max.	400 ms 550 ms 625 ms 870 ms 50 ms 60 ms
Delay-on de-energisation with E-STOP typ. with E-STOP max. with power failure typ. $U_B = 24 VDC$ with power failure max. $U_B = 24 VDC$ with power failure typ. $U_B = 240 VAC$ with power failure max. $U_B = 240 VAC$	15 ms 30 ms 120 ms 500 ms 900 ms 2.200 ms
Recovery time at max. switching frequency 1/s after E-STOP after power failure	50 ms + t_v 2,250 ms

Up to Category 4, EN 954-1 PNOZ XV2.1

Delay time t_v selectable	0.10 s, 0.20 s, 0.30 s, 0.40 s, 0.50 s, 0.60 s, 0.70 s, 0.80 s, 1.00 s, 1.50 s, 2.00 s, 3.00 s Order no.: 774 552
fixed	0.00 s, 0.50 s, 1.00 s, 2.00 s, 4.00 s, 6.00 s, 8.00 s, 10.00 s, 15.00 s, 20.00 s, 25.00 s, 30.00 s Order no.: 774550
Repetition accuracy	0.00 s, 5.00 s, 10.00 s, 20.00 s, 40.00 s, 60.00 s, 80.00 s, 100.00 s, 150.00 s, 200.00 s, 250.00 s, 300.00 s Order no.: 774558
Time accuracy	0.5 s Order no.: 774550
Waiting period with a monitored reset	2 %
Min. start pulse duration with a monitored reset	-15% / +15% +50 ms
Simultaneity, channel 1 and 2	300 ms
Supply interruption before de-energisation	30 ms
Environmental data	
EMC	EN 60947-5-1, EN 61000-6-2, EN 61000-6-4
Vibration in accordance with EN 60068-2-6	
Frequency	10 - 55 Hz
Amplitude	0.35 mm
Climatic suitability	EN 60068-2-78
Airgap creepage	VDE 0110-1
Ambient temperature	-10 - 55 °C
Storage temperature	-40 - 85 °C
Protection type	
Mounting (e.g. cabinet)	IP54
Housing	IP40
Terminals	IP20
Mechanical data	
Housing material	
Housing	PPO UL 94 V0
Front	ABS UL 94 V0
Max. cross section of external conductors with screw terminals	
1 core flexible	0.20 - 4.00 mm²
2 core, same cross section, flexible:	
with crimp connectors, without insulating sleeve	0.20 - 2.50 mm²
without crimp connectors or with TWIN crimp connectors	0.20 - 2.50 mm²
Torque setting with screw terminals	0.60 Nm
Dimensions (H x W x D)	87 mm x 90 mm x 121 mm
Weight	580 g Order no.: 774550, 774552, 774558 570 g Order no.: 774554

The standards current on **04/03** apply.

Max. continuous current

Number of contacts	I_{max} (A) at U_B DC	I_{max} (A) at U_B AC
1	8.00 A	8.00 A
2	7.00 A	7.00 A
3	5.70 A	5.70 A
4	5.00 A	5.00 A

Order reference

Type	Features	Terminals	Order no.
PNOZ XV2.1	24 - 240 VAC/DC	0.5 s fixed	Screw terminals 774 554
PNOZ XV2.1	24 - 240 VAC/DC	3 s selectable	Screw terminals 774 552

Up to Category 4, EN 954-1 PNOZ XV2.1

Type	Features		Terminals	Order no.
PNOZ XV2.1	24 - 240 VAC/DC	30 s selectable	Screw terminals	774 550
PNOZ XV2.1	24 - 240 VAC/DC	300 s selectable	Screw terminals	774 558