



[View larger image](#) [Printer Friendly Version](#)

Manual Swivel Vise Mitering

- Model Number : **MH-916JRP**
- Design Style : **Hinge Type**

Specifications

Max. Capacity	Round	230 mm (9")	
	Square	230 mm (9")	
	Rectangular(H x W)	230 x 370 mm (9" x 14.5")	
Saw Blade	Speed	50Hz	21,32,48,77 m/min (68,104,156,251 fpm)
		60Hz	25,39,57,92 m/min (82,127,186,300 fpm)
	Size (LxWxT)	3350L x 27W x 0.9Tmm (132" x 1.06" x 0.035")	
	Tension	Manual	
Motor Output	Saw Blade	2 HP (1.5 KW)	
	Coolant	1/8 HP (0.1 KW)	
Table Height	650 mm (25.6")		
Net Weight	410 kgs (902 lbs)		
Floor Space(LxWxH)	1600 x 710x 1080 mm (63" x 28" x 42.5")		
Shipping Space(LxWxH)	1700 x 787 x 1220 mm (67" x 31" x 48")		

Machine Features

MH-916JRP Machine Features

Structure

- Heavy-duty hydraulic cylinder with precision ground hinge support
- Cast iron quick set up vise
- Pan shaped base with built-in coolant & hydraulic system

Blade Drive

- 2 hp motor, heavy-duty reducer, & variable step drive assembly
- 4-speed transmission with the best worm gear and shaft

Blade Guidance & Lubrication System

- Carbide blade guides with roller bearings

- Two additional bearings to support blade from the top
- Rigid guide arms mounted on extra wide precision ground dovetail slide
- Integral coolant system
- Blade brush

Control & Automation

- Down feed rate & cutting pressure control via hydraulic down feed valve
- Simplified control switches mounted on saw head

Material Feeding & Clamping

- Cast iron vises
- Secure clamping via dependable manual lead screw system
- Anti-slip hand wheel

Safety

- Conduits protection measure
- Orange alert safety design

Standard Accessories

- Easy blade change with front access at waist level
- Bi-metal saw blade
- Tool box, leveling pads, and an additional wire brush
- Operation & parts manual

*All designs and specifications are subject to change without notice or obligation

 **Floor plan**

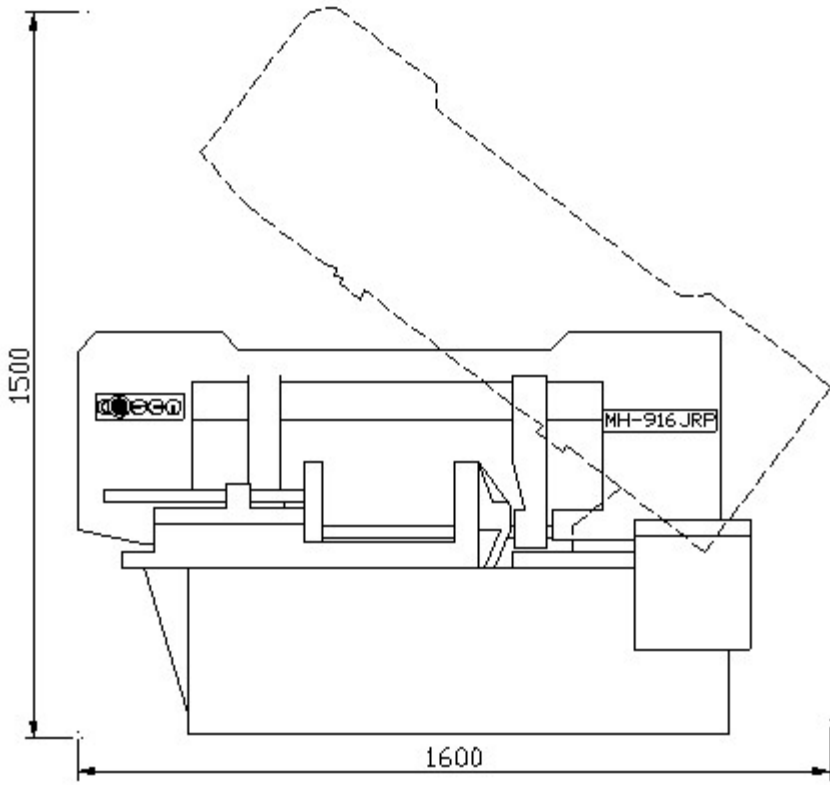
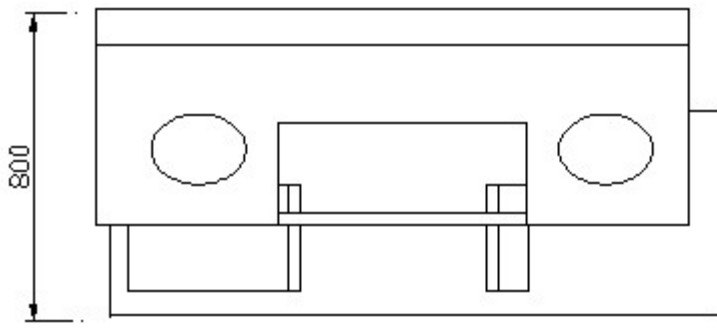

Close 