



[View larger image](#)

[Printer Friendly Version](#)

Manual Swivel Vise Mitering

- ▣ Model Number : **MH-812LC**
- ▣ Design Style : **Hinge Type**

Specifications

Max. Capacity	Round	200 mm (8")	
	Square	180 mm (7")	
	Rectangular(H x W)	180 x 290 mm (7" x 11.4")	
Saw Blade	Speed	50Hz	15,24,39,66 m/min (49,80,129,217 fpm)
		60Hz	18,29,47,79 m/min (59,96,155,260 fpm)
	Size (LxWxT)	2720L x 27W x 0.9Tmm (107" x 1.06" x 0.035")	
	Tension	Manual	
Motor Output	Saw Blade	1 HP (0.75 KW)	
	Coolant	1/8 HP (0.1 KW)	
Table Height	630 mm (24.8")		
Net Weight	220 kgs (484 lbs)		
Floor Space(LxWxH)	1450 x 625x 1145 mm (56" x 24.5" x 45")		
Shipping Space(LxWxH)	1475 x 762x 1220 mm (58" x 30" x 48")		

Machine Features

MH-812LC Machine Features

Structure

- Heavy-duty hydraulic cylinder with precision ground hinge support
- Cast iron quick set up vise
- Pan shaped base with built-in coolant & hydraulic system

Blade Drive

- 2 hp motor, heavy-duty reducer, & variable step drive assembly
- 4-speed transmission with the best worm gear and shaft

Blade Guidance & Lubrication System

- Carbide blade guides with roller bearings

- Two additional bearings to support blade from the top
- Integral coolant system
- Blade brush

Control & Automation

- Down feed rate & cutting pressure control via hydraulic down feed valve
- Simplified control switches mounted on saw head

Material Feeding & Clamping

- Cast iron vises
- Secure clamping via dependable manual lead screw system
- Anti-slip hand wheel

Safety

- Conduits protection measure
- Orange alert safety design

Standard Accessories

- Easy blade change with front access at waist level
- Bi-metal saw blade
- Tool box, leveling pads, and an additional wire brush
- Operation & parts manual

*All designs and specifications are subject to change without notice or obligation

 **Floor plan**

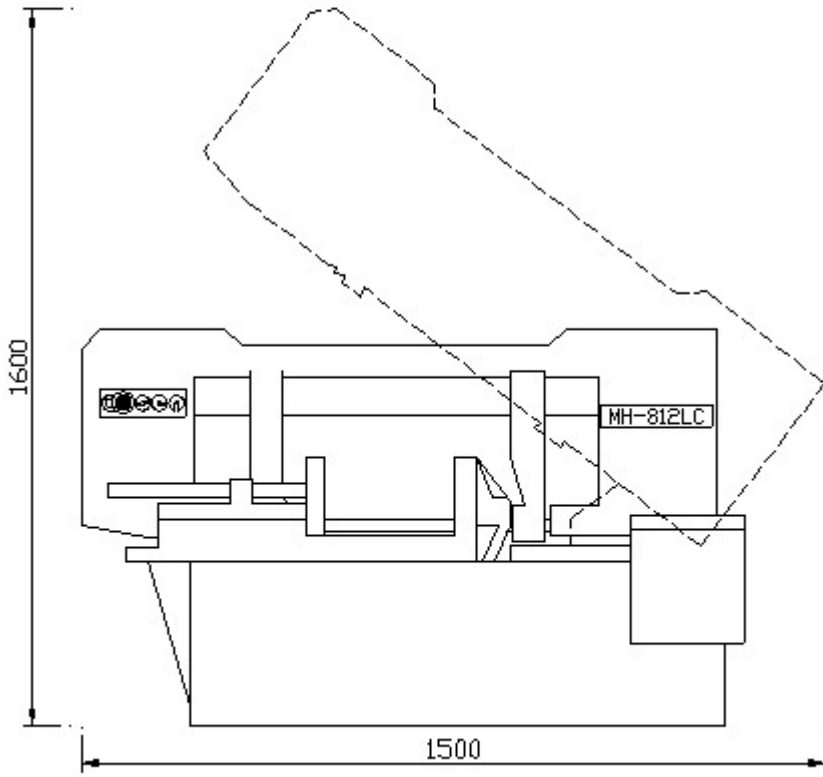
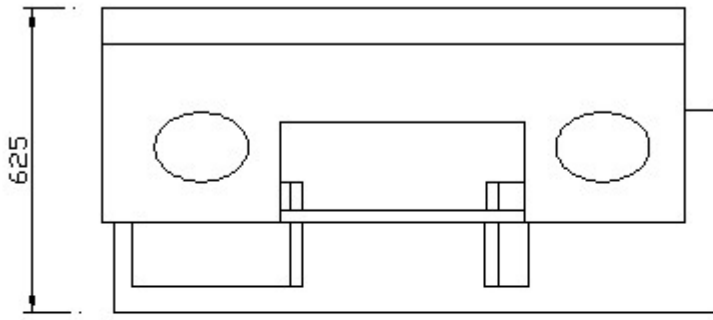

Close 