

Category 4, EN 954-1 PNOZ 2VQ



Emergency stop relay and safety gate monitor in accordance with VDE 0113-1, 11/98, EN 60204-1, 12/97 and IEC 204-1, 11/98.

Features

- Dual-channel operation with or without the detection of shorts across the input contacts
- 2 separate release times can be selected
- Supply voltage: 24 VDC only

Approval

	PNOZ 2VQ
	●
	●
	●

Technical Details	PNOZ 2VQ
Electrical Data	
Supply Voltage	24 VDC
Tolerance	85 ... 110 %
Power Consumption	Approx. 6.5 W
Voltage and Current at the Input and Rest Circuits and Feedback Control Loop	24 VDC, 50 mA
Switching Capability	
EN 60947-4-1, 10/91	
Safety contacts	AC1: 240 V/8 A/2000 VA, 400 V/5 A/2000 VA DC1: 24 V/8 A/200 W
EN 60947-5-1, 10/91 (DC13: 6 cycles/min.)	AC15: 230 V/5 A; DC13: 24 V/7A
Auxiliary contacts and time-delayed safety contacts	
EN 60947-4-1, 10/91	AC1: 240 V/4 A/1000 VA, DC1: 24 V/4 A/100 W
EN 60947-5-1, 10/91 (DC13: 6 cycles/min.)	AC15: 230 V/4 A; DC13: 24 V/4A
Output Contacts	3 safety contacts (N/O) 2 time-delayed safety contacts (N/O) 1 auxiliary contact (N/C)
Sum of Max. Total Current on Outputs	Max. 22 A
Contact Fuse Protection (EN 60947-5-1, 10/91)	10 A quick or 6 A slow
Times	
Delay-on Energisation	Max. 200 ms
Delay-on De-energisation	Max. 50 ms
Delay Time t_1 (57-58)	0.1/0.2/0.3/0.4/0.5/0.6/0.7/0.8/1/1.5/2/3 s
Delay Time t_2 (67-68)	1/2/3/4/5/6/7/8/10/12/15/20 s
Simultaneity channel 1/2	Approx. 150 ms
Max. Supply Interruption before De-energisation	Approx. 35 ms
Mechanical Data	
Maximum Cross Section of External Conductors	2 x 1.5 mm ² Single-core or multi-core with crimp connectors
Dimensions (H x W x D)	87 x 112.5 x 121 mm
Weight	650 g

Description

- 112.5 mm, P-93 housing, DIN-Rail mounting
- Positive-guided relay outputs:
 - 3 safety contacts (N/O)
 - 2 time-delayed safety contacts (N/O)
 - 1 auxiliary contact (N/C)
- Connections for
 - E-STOP button
 - safety gate limit switch
 - reset button
- Detection of shorts across the input contacts
- LEDs for channel 1/2 and power

- Increase in the number of safety contacts available by connecting expander modules.

Operating Modes

- Single-channel operation
- Dual-channel operation
- Automatic reset
- Manual reset

Category 4, EN 954-1 PNOZ 2VQ

Internal Wiring Diagram

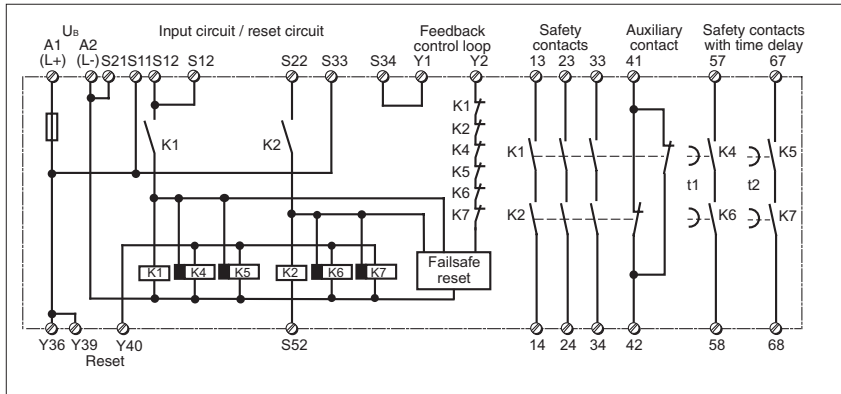

● Increase in safety contacts
The number of output contacts can be increased by using expander modules or relays/contactors with positive-guided contacts.

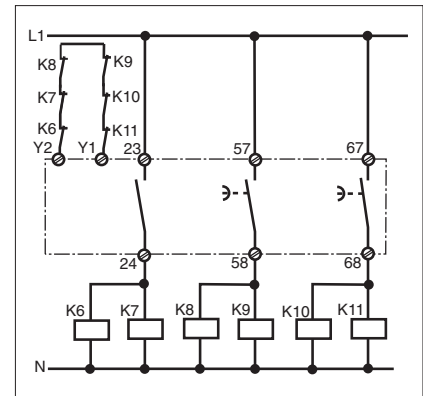

External Wiring

● Example 1
Single-channel E-STOP wiring with manual reset.

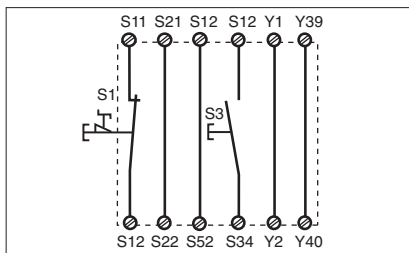

● Example 4
Dual-channel safety gate control with manual reset.

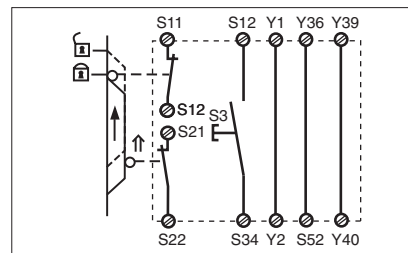

● Example 2
Dual-channel E-STOP wiring with manual reset.

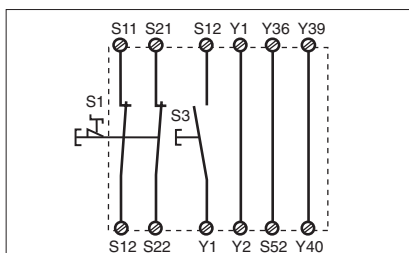

– Key

- S11/2: E-STOP or safety gate switch
- S3: Reset button
- Switch operated
- Gate open
- Gate closed

● Example 3
Dual-channel safety gate control with automatic reset.

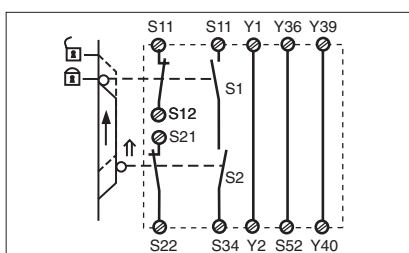

Category 4, EN 954-1 PNOZ 2VQ

General Technical Data

Unless stated otherwise in the technical details for the specific unit

Electrical Data

Frequency Range AC	50 ... 60 Hz
Residual Ripple DC	160 %
Contact Material	AgSnO ₂
Continuous Duty	100 %

Environmental Data

EMC	EN 50081-1, 01/92, EN 50082-2, 03/95
Vibration in accordance with EN 60068-2-6, 04/95	Frequency: 10 ... 55 Hz, Amplitude: 0.35 mm
Climatic Suitability	DIN IEC 60068-2-3, 12/86
Airgap Creepage	DIN VDE 0110 part 1, 04/97
Ambient Temperature	-10 ... +55 °C
Storage Temperature	-40 ... +85 °C

Mechanical Data

Torque Setting on Connection Terminals	0.6 Nm (screws)
Mounting Position	Any
Housing Material	Thermoplast Noryl SE 100
Protection	Mounting: IP 54 Housing: IP 40 Terminal Range: IP 20

The units were tested in accordance with the relevant standards current at the time of development.

Order References

Type	U _B	Order No.
PNOZ 2VQ	24 V DC	774 013