

2. น้ํงรํานสําร้จรูป (SCAFFOLDING)

แบบเห็ล็ก หวองโลหะการ โทร. 02-322-5499

FORMWORK WONGLOHAKARN TEL. 02-322-5499

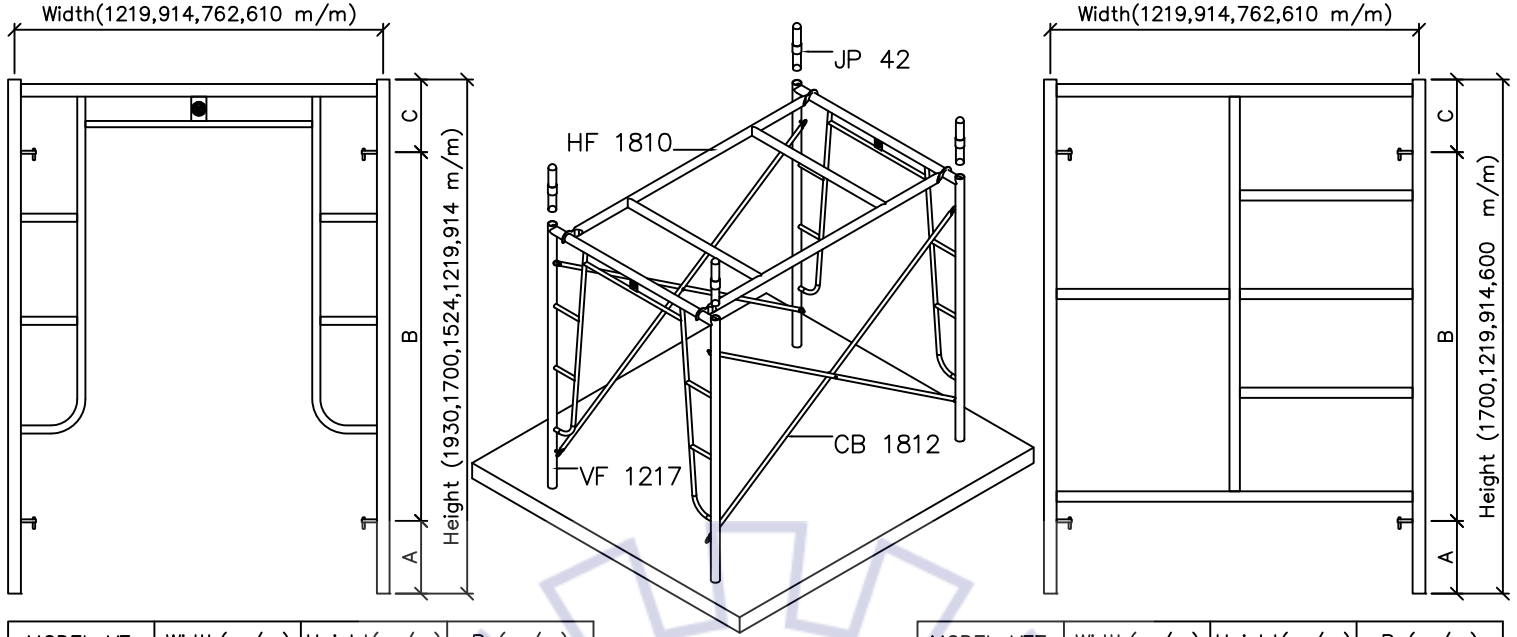

MODEL VF.	Width(m/m)	Height(m/m)	B (m/m)
VF 1219	1219	1930	1219
VF 1217	1219	1700	1219
VF 1215	1219	1524	1219
VF 1212	1219	1219	914
VF 1209	1219	914	610
VF 0917	914	1700	1219
VF 0717	762	1700	1219

MODEL VFT.	Width(m/m)	Height(m/m)	B (m/m)
VF 1217 T	1219	1700	1219
VF 1212 T	1219	1219	914
VF 1209 T	1219	914	610
VF 1206 T	1219	600	280
VF 1204 T	1219	490	280
VF 0917 T	914	1700	1219
VF 0915 T	914	1524	1219
VF 0912 T	914	1219	914
VF 0909 T	914	914	610
VF 0906 T	914	600	280
VF 0717 T	762	1700	1219
VF 0617 T	610	1700	1219

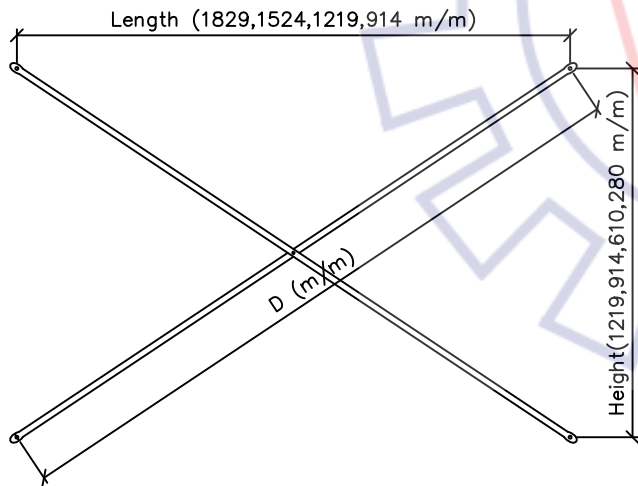

MODEL CB.	Length(m/m)	Width(m/m)	D (m/m)
CB 1812	1829	1219	2198
CB 1809	1829	914	2045
CB 1806	1829	610	1928
CB 1802	1829	280	1850
CB 1512	1524	1219	1952
CB 1509	1524	914	1777
CB 1506	1524	610	1642
CB 1502	1524	280	1549
CB 1212	1219	1219	1724
CB 1209	1219	914	1524
CB 1206	1219	610	1363
CB 1202	1219	280	1251
CB 0906	914	610	1099

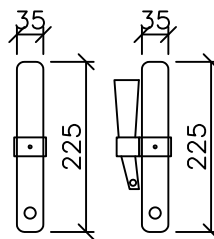
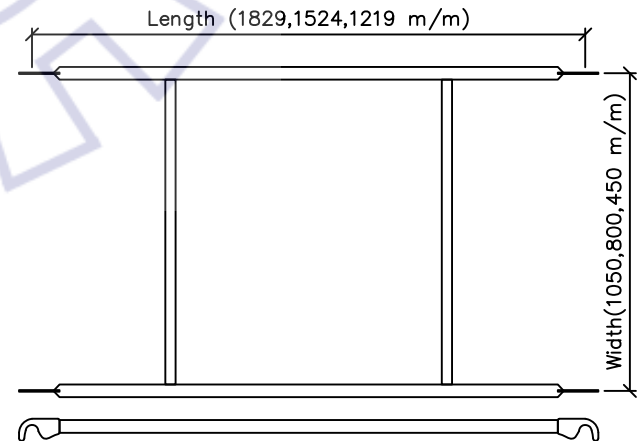

MODEL JP.	Size(m/m)
JP 42	∅35x225
JP 42EX	∅35x225+ต้ล้ม

MODEL HF.	Length(m/m)	Width(m/m)
HF 1810	1829	1050
HF 1808	1829	800
HF 1804	1829	450
HF 1510	1524	1050
HF 1508	1524	800
HF 1504	1524	450
HF 1210	1219	1050
HF 1208	1219	800
HF 1204	1219	450

น้ํงรํานสําร้จรูป ขนาดอ้ันๆ หรือ แบบเห็ล็กรูปแบบตํางๆสามารถส้งผล้ตได้