



Guide to contents - applicable to

5MC software V55

1 Mechanical Outlines

Referring to the appropriate size of Qfe, mount the Qfe ensuring that correct clearances are maintained for adequate ventilation and operation of the Qfe.

2 Wiring Diagrams

Referring to the appropriate **Wiring Diagram**, install the Qfe electrical connections ensuring that the correct control supply voltage is used and is within its specified operating limits as described on the product specification

ACCESS

Caution Always replace the cover panel on the unit after gaining access to the electrical connections.

The unit requires two AC supplies:
A 3 phase balanced Mains Supply to provide the source of power for the controlled motor.
A single phase supply: 115V/230V, 50Hz/60Hz, for the internal control circuitry.

IMPORTANT Ensure that the voltage selector switch position corresponds to the control supply before you apply the control supply voltage.



ISOLATION

Caution: The Qfe uses semiconductor devices in the main circuit and is not designed to provide isolation. For this reason isolation means must be installed in the supply circuit in accordance with the appropriate wiring and safety regulations.

The Mains Supply and the Control Supply each require protection. Although all units have electronic overload protection, the installer should always place fuse protection **between** the unit and the Mains Supply, **not between** the unit and the motor. Semiconductor fuses can be supplied for short circuit protection of the semiconductors.

3 Keypad operation and basic set-up

Refer to this, for familiarisation with the keypad controls of the Qfe. Use the illustration of the Basic Menu structure to find Qfe menu items on the display.

4 Set-up examples

Set-up basic Qfe operating parameters, if necessary, by following one or all of the examples described here.

5 Product information

Refer to product information for details of Design Standards and Approvals, operating and storage limits and other installation instructions.

Further Information

For further information about the Qfe soft start motor controller, detailed Qfe manuals and application notes are available on the Fairford website <http://www.fairford.co.uk>, or from Fairford direct (see back page for contact details).

1 Mechanical Outlines

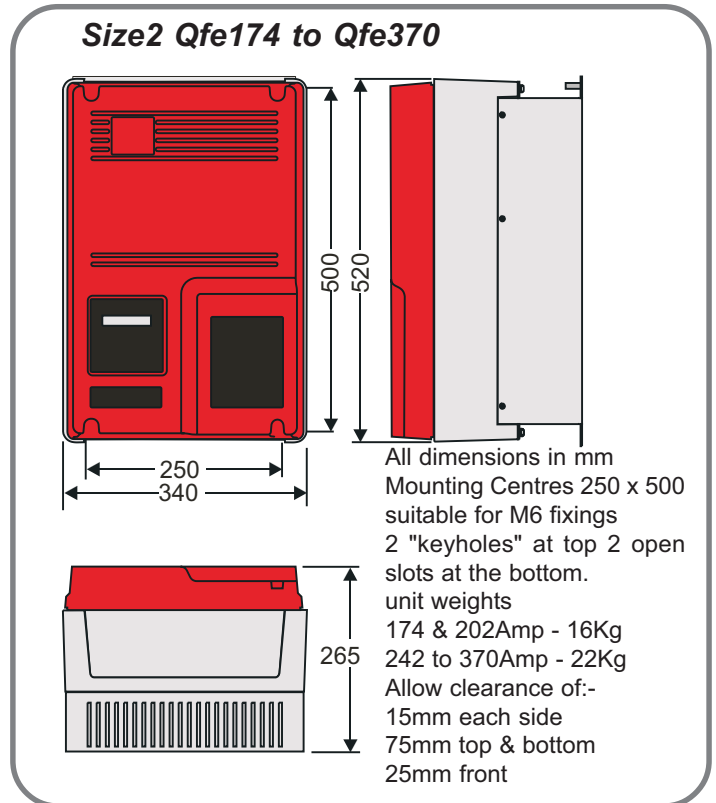
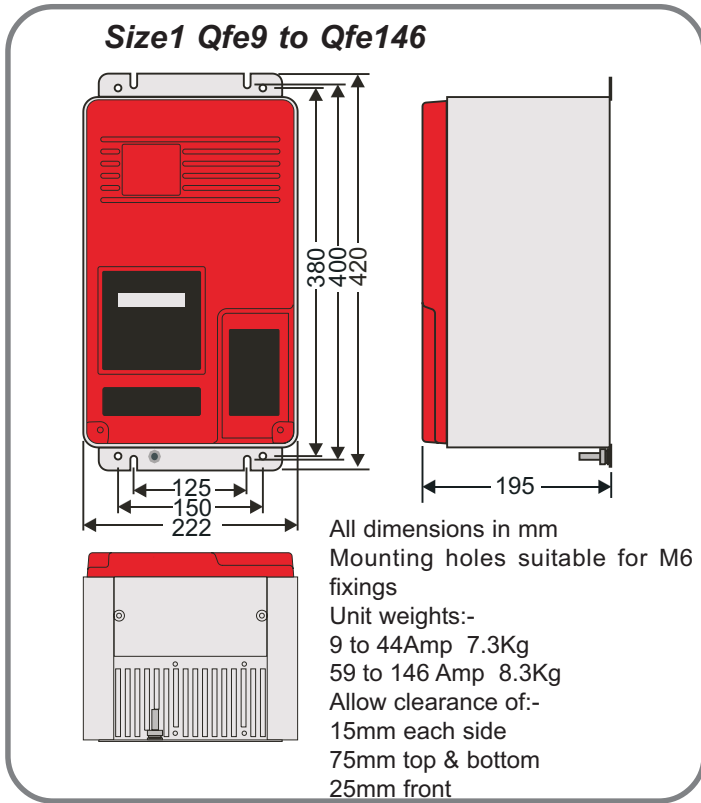

Note 1: - Chassis size 2

To allow for larger cross sections of insulated cable on models of Qfe in chassis size 2, extended gland plates are available as an option.

Note 2: - Chassis size 3

When fitting the unit into a cabinet, allowance must be made for 90° opening of the hinged unit doors.

Add 90mm for the left-hand door which has the plastic moulding incorporating the control card and keypad, and 30mm for the right hand door i.e. 90 + 675 + 30 = 795mm as an overall cabinet opening.

Note 3: - Enclosures

When fitting a Qfe into a cabinet, ventilation must be provided if the heat output of the unit is greater than the cabinet will dissipate.

Use the following formula to determine the fan requirement. An allowance has been incorporated into the formula so that the figure for "Q" is the air delivery quoted in the fan suppliers data.

An approximation of the heat produced by the Qfe (in Watts) can be made by multiplying the full load line current by three. Exact figures for unit full load current are in the Qfe manual.

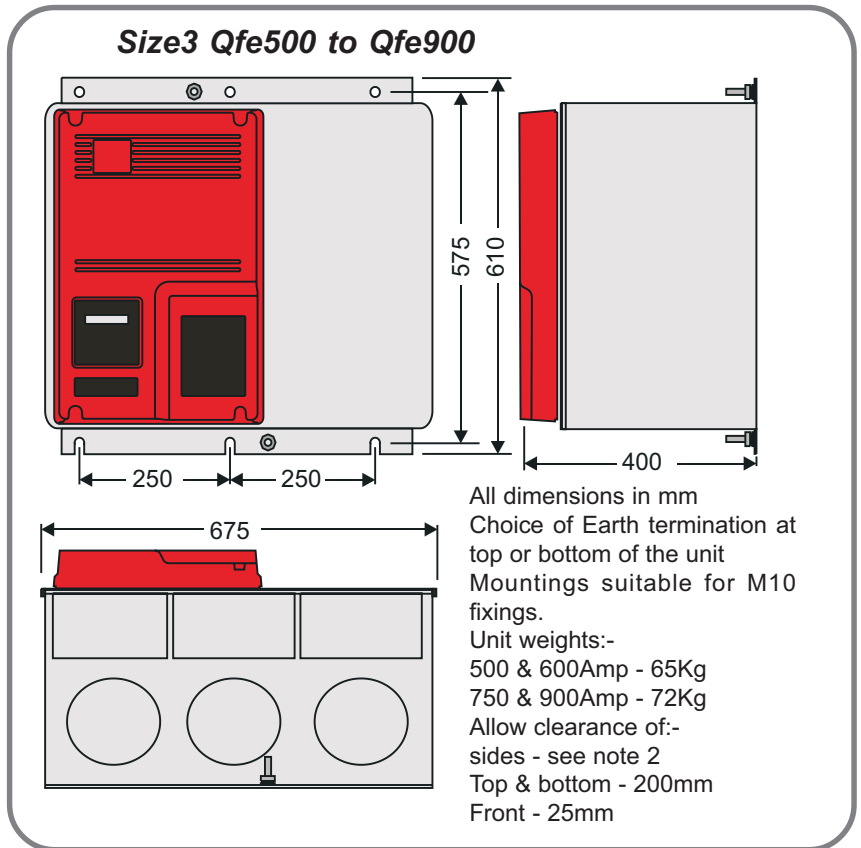

$$Q = \frac{4 \times Wt}{(t_{max} - t_{amb})}$$

- Q = required volume of air (cubic metres per hour - m³/h)
 - Wt = heat produced by the unit and all other heat sources within the enclosure (Watts)
 - t_{max} = maximum permissible temperature within the enclosure (40°C for a fully rated Qfe)
 - t_{amb} = temperature of the air entering the enclosure (°C)
- If you prefer to work in CFM, substitute °F for °C. Q is now in CFM.

2 Wiring Diagrams

Fig 2.1 Control circuit wiring

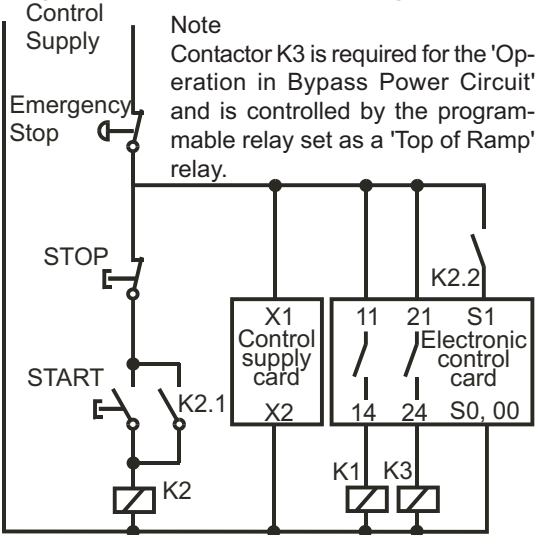

Note: Extra X1 and X2 on Size 3 for fan supply

The **Electronic control card** is located underneath the cover in the Size 1 and 2 units and inside the hinged door panel in Size 3 units. Connections shown in the control circuit wiring diagram are made to the electronic control card terminals as shown in fig.2.2 below.

Fig 2.2

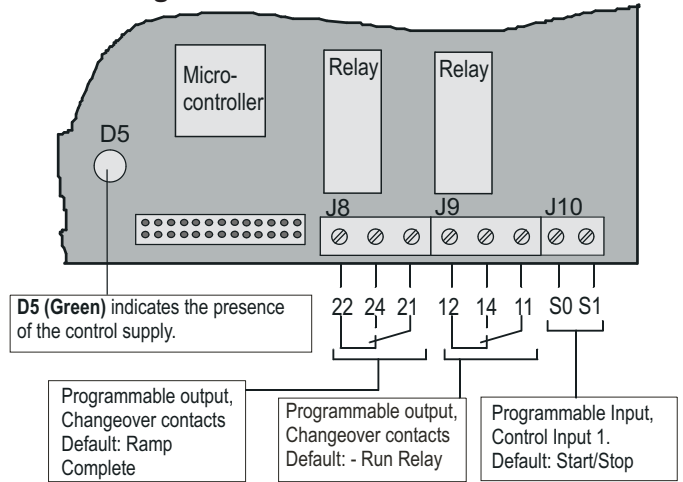

Use the control circuit with one of these power circuits

Fig 2.3 Power circuit for In-Line connection of motors (see note 3).

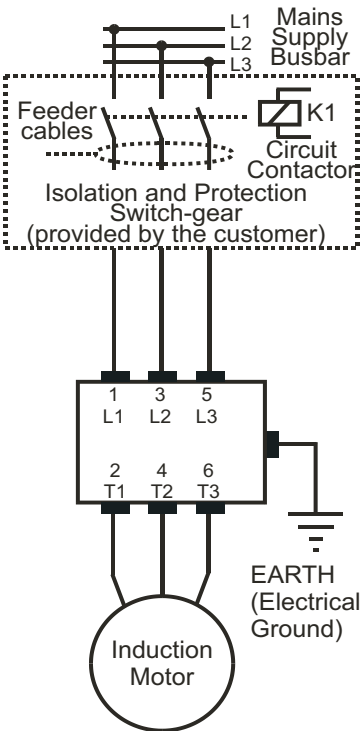

Fig 2.4 Power circuit for In-Delta connection of motors (see note 4).

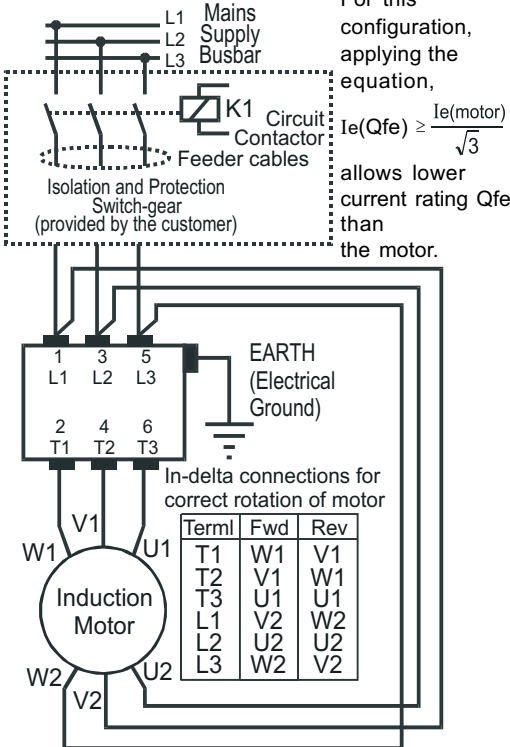
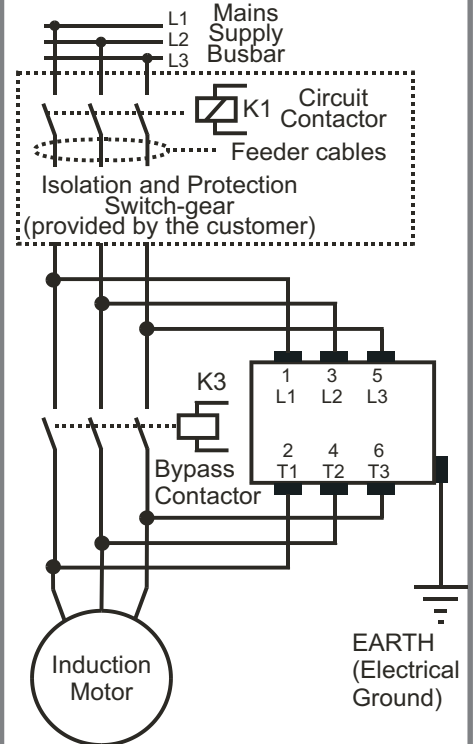

Fig 2.5 Power circuit for bypass operation (see note 5).



Important

Note 1: Correction capacitors:

Power factor correction capacitors must **NOT** be positioned on the output of the power circuit.

Note 2: Fuse Selection:

Where semiconductor type fuses are required, they should be selected from the table in Section 5.

Note 3: The in-line configuration shown in Fig 2.3 requires that the firing mode be set to '0'.

Note 4: The **In-Delta configuration** as in Fig 2.4 requires that the Firing Mode be set to '1'.

An in-line contactor controlled by the starter **MUST** be used with the In-Delta firing mode.

Note 5: The **bypass configuration** as in Fig 2.5 is automatically detected as "Auto bypass" is set as default.

3 Keypad operation and basic set-up

ALWAYS ENSURE THAT THE KEYPAD CABLE IS PLUGGED IN BEFORE APPLYING POWER TO THE UNIT

When wired as Fig 2.1, page 3, the Qfe display will indicate start up messages followed by 'Stopped and ready'. At this point:

- the Qfe will start the motor when the keypad 'START/STOP' key is pressed but not when the START switch as shown in Fig.2.1 is closed.
- the Qfe parameters are set to factory default which may not be ideal for the required application.

The examples in section 4 show how to set up some of the essential Qfe operating parameters using the keypad. Once these are understood, other Qfe settings, as indicated in the programming Menu Structure below, can be set in a similar manner (The corresponding default settings are shown in brackets). For the full menu structure, refer to the Qfe Manual.

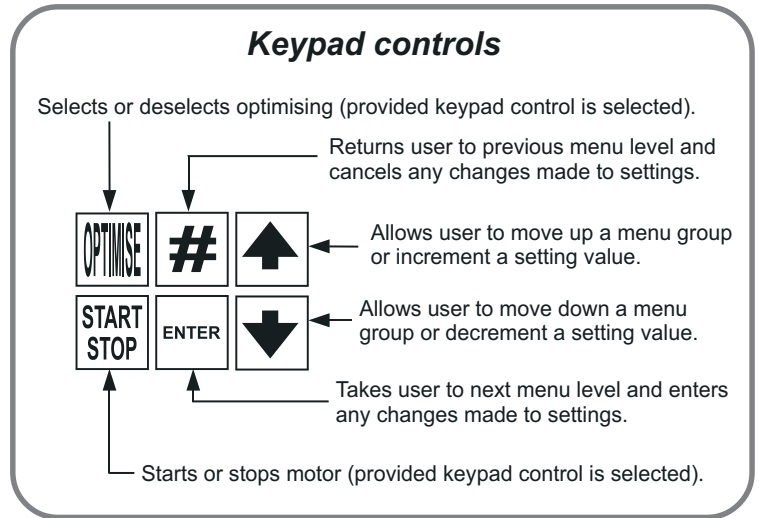

Menu structure *Typical Keypad menu. ontact Fairford Electronics Ltd for details.*

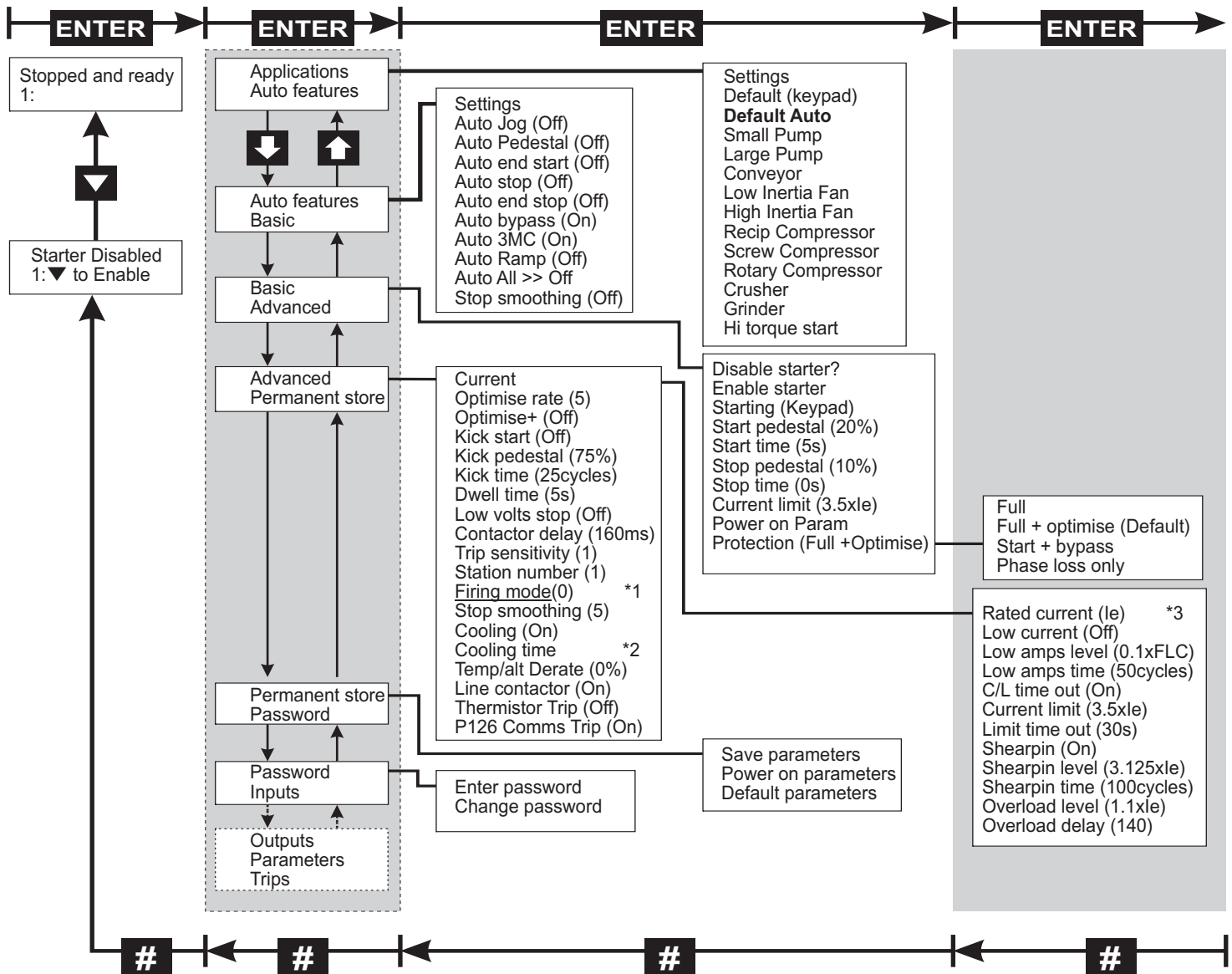

*1 The "Firing mode" must be set to '1' for the In-Delta configuration.

*2 The "Cooling time" is dependant on the Model range, Duty rating and Heatsink temperature.

*3 The "Rated current" setting is for reference only and is not user adjustable.

Starter Enable/Disable

An additional safety feature has been added so that following certain actions the starter will be disabled. It is strongly recommended that before any changes to parameter values are made, that the starter is **disabled** via the **Basic Menu**. Once disabled, the starter remains unable to drive the load, until it has been **enabled** via the **Basic Menu**, or the control supply is removed and reapplied, or the ▼ key is pressed when prompted.

4 Set-up examples

1 Setting the Qfe for large pump application

- ① With 'Starter Disabled' shown on the display, press **ENTER** key once.
- ② With 'Applications' shown on the top line of the display press **ENTER** once.
- ③ With 'Settings' shown at the top of the display press **↓** key three times until 'Large pump' is shown at top of display.
- ④ Press **ENTER** once to select large pump. The display will indicate the parameters changing in short intervals.
- ⑤ With the display top line indicating 'Send to store?', press **ENTER** to save the settings for a large pump to permanent store. Display will flash the message 'Storing' twice to indicate this has been done.
- ⑥ At any of the above stages pressing **#** will return the user to the previous menu. The Qfe will not start until the control display indicates 'Stopped and ready'.

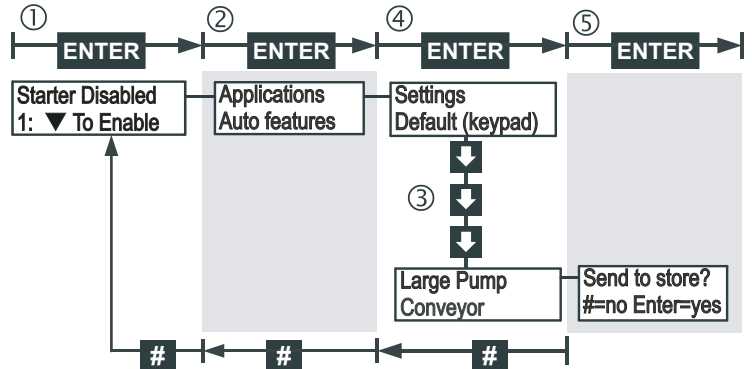

2 Setting the Qfe for remote starting and stopping.

- ① With 'Starter Disabled' shown on the display, press **ENTER** key once.
- ② With 'Applications' shown on the top line of the display press **↓** key twice until 'Basic' is shown at the top of the display.
- ③ Press **ENTER** once to select Basic menu.
- ④ Press **↓** key twice until 'Starting' is shown at top of the display then press **ENTER** once to select starting option menu.
- ⑤ With display now indicating 'Starting' on top line press **ENTER** to toggle from 'Keypad Starting' to 'Remote Starting' as shown on bottom line of display.
- ⑥ At any of the above stages pressing **#** will return the user to the previous menu.

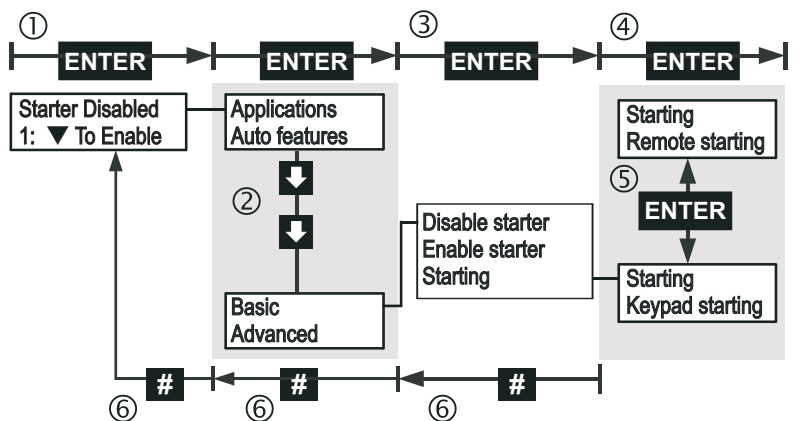

The Qfe will now start and stop remotely from the START and STOP switches shown in Figure 2.1, but will return to keypad starting if the control supply on terminals X1 and X2 is removed. Alternatively, to return to keypad starting and stopping, repeat the above procedure and select 'Keypad Starting' at step 5. **To keep the remote start/stop setting after removal of the control supply, the settings must be permanently saved (See 3 below).**

3 Permanently saving parameters set by user.

- ① With 'Starter Disabled' shown on the display, press **ENTER** key once.
- ② With 'Applications' shown on the top line of the display press **↓** key four times until 'Permanent Store' is shown at top of display.
- ③ Press **ENTER** once to select Permanent Store menu.
- ④ With 'Save Param' shown at top of display press **ENTER** once to permanently save parameters. Display will flash twice to indicate this has been done.
- ⑤ At any of the above stages pressing **#** will return the user to the previous menu.

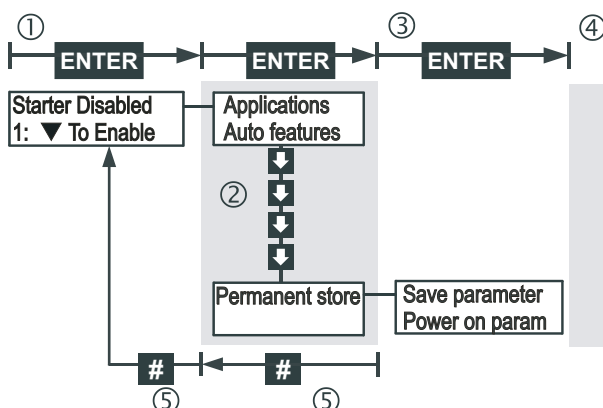

5 Product information

5.1 Design standards and Approvals

IEC 60947-4-2; EN 60947-4-2 'AC Semiconductor Motor Controllers and Starters'.

Models Qfe and Qfe-G bearing the UL Listing mark, , are UL Listed to U.S. and Canadian safety standards.

5.2 Basic ratings

	Connector/ terminal	Qfe range	Qfe-G range	Qfe-E range	Rated freq.
Rated operational voltage	L1,L2,L3	230-460V AC rms (-15% +10%)	400-575V AC rms (-15% +10%)	500-690V AC rms (-15% +10%)	50/60Hz (±2Hz)
Control supply voltage (Us)	X1,X2	115V or 230V AC rms (-15% + 10%)			
Control input voltage (Uc)	S0,S1	12V/24VDC or 115/230VAC			
Output relays	11,12,14 and 21,22,24	AC1 230V, 3A			
Rated operational current(Ie)	See Semiconductor Fuse types table in Section 5.3				
Form designation	Form 1				

Index Ratings

In line with the stated IEC starting duties, starters of 242 Amps and above have an enforced off period of 7 minutes set as standard. During this period the display indicates "Stopped. Cooling", and the starter will not respond to a start signal.

Model name	Ie (A)	Standard operation AC-53a: X-Tx: F-S	Bypassed operation AC-53b: X-Tx: OFF-time
Qfe9 to Qfe105	9A to 105A	AC-53a: 5-4: 99-10 AC-53a: 3-35 :99-10	AC-53b: 5-4: 120 AC-53b: 3-35 :120
Qfe146 to Qfe202	146A to 202A	AC-53a: 4-6: 99-10 AC-53a: 3-35 :99-10	AC-53b: 4-6: 120 AC-53b: 3-35 :120
Qfe242 to Qfe900	242A to 900A	AC-53a: 4-6: 60-3 AC-53a: 3-35 :60-3	AC-53b: 4-6: 360 AC-53b: 3-35 : 360

Further Information

Document No TF0120 'Guide to Soft Start Drive Product Information', describes the rating index and the meaning of other IEC 60947-4-2 product information in more detail. This is available upon request from Fairford Electronics Ltd.

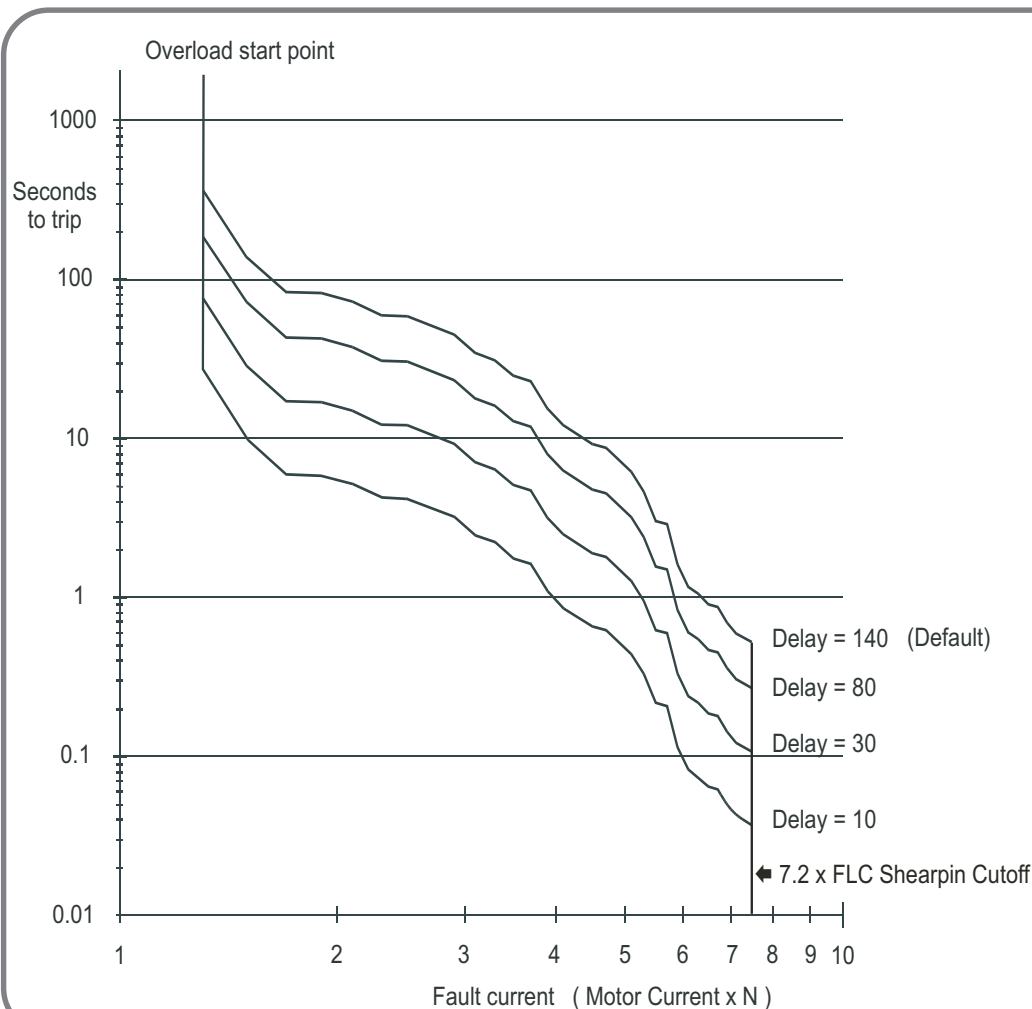

'Current limit', 'Overload level' and 'Overload delay' settings may be adjusted to limit overload currents in accordance with the trip curves shown here (See Menu structure in Section 3 for default settings). For motors with FLC's lower than the rated current of the Qfe the Overload level' may be adjusted using the following formula:

$$\text{Overload level} = \text{Motor FLC} \times 1.1(\text{A})$$

Note: The overload monitors one of the phases only and the 'Current Limit' level is only active during motor starting.

IMPORTANT

It is recommended that the control supply is maintained between starts to ensure the integrity of the overload, which will reset on it's removal.

5.3 Safety and installation.

Rated insulation voltage (Ui)	690V
Ingress Protection	IP20
Pollution degree	3
Short circuit co-ordination	Type 1

UL requires Recognized special purpose fuses (JFHR2), for the protection of semi-conductor devices, rated 700 Vac, as indicated in Table 5.3, be used to obtain the short circuit ratings required by UL.

Suitable for use on a circuit capable of delivering not more than the RMS Symmetrical Amperes indicated in Table 5.3 at maximum rated operational voltage, when protected by Semiconductor Fuse type, Manufactured by Company and Mod. No. indicated in Table 5.3. Fuse rated 700 Vac, Amps as indicated in Table 5.3.

These fuses are for short circuit protection of the semiconductors and must be mounted externally by the user **between** the unit and the mains supply, **not between** the unit and the motor.

5.4 Normal service conditions.

Ambient temperature	0°C to 40°C. Above 40°C de-rate linearly by 2% of unit FLC per °C to a maximum of 40% at 60°C.
Transport and Storage	-25°C to +60°C (continuous), -25°C to +75°C (not exceeding 24 hours).
Altitude	1000m. Above 1000m de-rate linearly by 1% of unit FLC per 100m to a maximum altitude of 2000m.
Humidity	max. 85% non-condensing, not exceeding 50% at 40°C.

Table 5.3 Semiconductor Fuse types

Model Name	Ie (Arms)	Short Circuit Amp RMS (kA)	UL Recognized JFHR2 Fuses		
			Bussman International Inc. Mod. No.	Ferraz Mod. No. 6.6 URD followed by	Amps
Qfe9	9A	5	170M3110	30 D08A 0063	63
Qfe16	16A	5	170M3110	30 D08A 0063	63
Qfe23	23A	5	170M3112	30 D08A 0100	100
Qfe30	30A	5	170M3112	30 D08A 0100	100
Qfe44	44A	5	170M3114	30 D08A 0160	160
Qfe59	59A	5	170M3115	30 D08A 0200	200
Qfe72	72A	10	170M3116	30 D08A 0250	250
Qfe85	85A	10	170M3116	30 D08A 0250	250
Qfe105	105A	10	170M3119	30 D08A 0400	400
Qfe146	146A	10	170M3119	30 D08A 0400	400
Qfe174	174A	10	170M3121	30 D08A 0500	500
Qfe202	202A	10	170M3121	30 D08A 0500	500
Qfe242	242A	10	170M4114	31 D08A 0500	500
Qfe300	300A	18	170M4114	31 D08A 0500	500
Qfe370	370A	18	170M4116	31 D08A 0630	630
Qfe500	500A	18	170M6113	33 D08A 0900	900
Qfe600	600A	30	170M6113	33 D08A 0900	900
Qfe750	750A	30	170M6116	33 D08A 1250	1250
Qfe900	900A	42	170M6116	33 D08A 1250	1250

Application Note for fuse selection: APP00004

5.5 EMC Emission and Immunity levels

EMC compliance is in accordance with EN 60947-4-2 which refers to the following basic standards:

	Basic standard	Level
IMMUNITY Severity level 3	IEC 61000-4-2 IEC 61000-4-6 IEC 61000-4-3 IEC 61000-4-4 IEC 61000-4-5	6kV contact or 8kV air discharge 140dBuV over 0.15-80MHz 10V/m over 80 -1000MHz 2kV/5kHz 2kV line to ground and 1kV line to line
EMISSION Equipment Class A (Industrial)	EN 55011	Class A

Note: EN 60947-4-2 is published as a harmonized standard under European Council Directive No.89/336/EEC in relation to the electromagnetic compatibility. (Official Journal of the European Communities ref. 97/C 270/06)

5.6 Control, Power and Earth terminations.

Control Terminations

All models - Terminals	Terminal type	Wire type	Cable cross section				Terminal tightening torque
			AWG		mm ²		
			Min.	Max.	Min.	Max.	
X1,X2, S0,S1 11,12,14 21,22,24	Screw clamp terminals	Solid or stranded.	22	14	0.3	2.5	4.4 lb.in. (0.5 Nm.)

Control, Power and Earth terminations, continued

Power and Earth Terminations

Size 1: Qfe9 to Qfe146 terminals		Terminal type	Conductor type	Cable cross section*		Terminal tightening torque
				AWG	mm ²	
Power	L1, L2, L3, T1, T2, T3.	M8 metric threaded studs	Use 75°C copper (CU) conductor only and the wire shall be fitted with close eyelet lug.	1/0	50	106 lb.in. (12 Nm.)
Ground	PE 	M8 metric threaded stud				

Size 2: Qfe174 to Qfe370 terminals		Terminal type	Conductor type	Cable cross section*		Busbar size (mm)*	Terminal tightening torque
				AWG	mm ²		
Power	L1, L2, L3, T1, T2, T3.	M8 metric threaded studs	Use 75°C copper (CU) conductor only and the wire shall be fitted with close eyelet lug or use busbar.	2 x 250MCM	2 x 120	20 x 6	106 lb.in. (12 Nm.)
Ground	PE 	M8 metric threaded stud					

Size 3: Qfe500 to Qfe900 terminals		Terminal type	Conductor type	Busbar size (mm)*		Terminal tightening torque
Power	L1, L2, L3, T1, T2, T3.	Two off M10 nuts and bolts	Use Busbar	45 x 20 60 x 10 80 x 10		212 lb.in. (24 Nm.)
Ground	PE 	M10 metric threaded stud				

To maintain approvals for cable connections, the Wire Terminals should be UL Listed or Recognised Wire Connectors and Soldering Lugs, fitted to the wire with specified Crimping Tools as indicated by the manufacturer.

* The conductor sizes indicated in the above table are the maximum allowed by UL for each chassis size. The actual conductor used must comply with local wiring regulations.

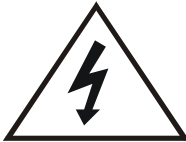
	<p>The owner, installer and user is responsible for the correct installation and use of the Qfe and must ensure that only qualified personnel install the Qfe and that the installation, operation and maintenance of the unit complies with the relevant Codes of Practice, Regulations and Statutory Requirements. The Manufacturer or his agent do not assume any liability, expressed or implied, for any consequence resulting from inappropriate, negligent or incorrect installation, application, use or adjustment of the product or circuit design, or from the mismatch of the unit to a motor. To prevent an electrical shock hazard the Qfe must be connected to a safety earth. The unit is not designed for use in hazardous areas. Use in such an area may invalidate the hazardous area certification.</p>
WARNING	

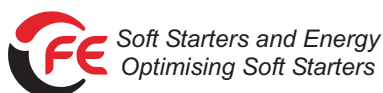

Fairford Electronics Limited, Coombe Works, Derby Road, Kingsbridge, Devon TQ7 1JL, United Kingdom

TEL: + 44 (0) 1548 857494 FAX: + 44 (0) 1548 853118 EMAIL: sales@fairford.co.uk WEB: www.fairford.co.uk

Registered No.: 1559267 England VAT No.: GB 367 2844 24



All rights reserved. No part of this publication may be reproduced or transmitted in any form or by any means, electronic or mechanical including photocopying, recording, or by any information storage or retrieval system without written permission.

Copyright ©Fairford Electronics Ltd. 2007 Document FD858816/Qfe-UL.

Published: May 2007 M-8588-F